

HYDRAULIC SEALS

PISTON SEALS

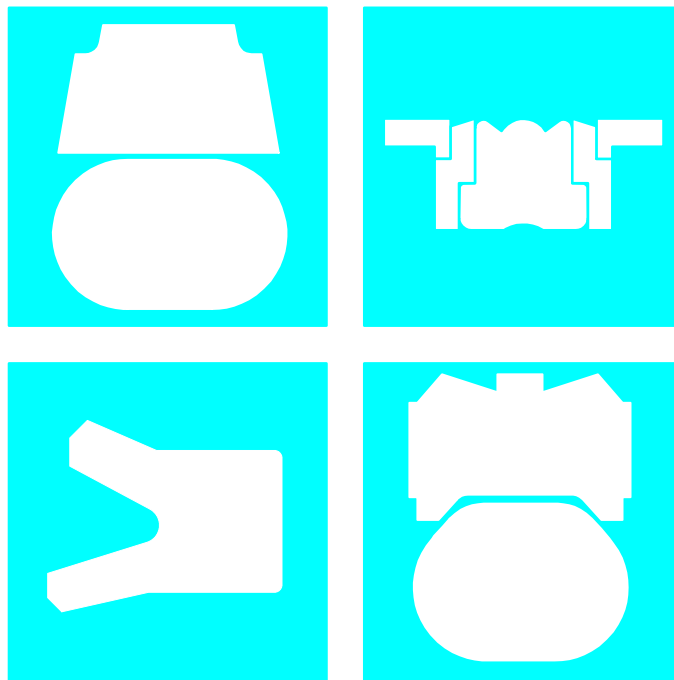



Piston Seals

Contents

Choice of Sealing Element	4
Design Instructions	8
Installation of Piston Seals	10
Turcon® Glyd Ring®	15
Turcon® Glyd Ring® T	23
Turcon® AQ-Seal® 5	31
Turcon® AQ-Seal®	39
POLYPAC® PHD Seal	47
Turcon® Stepseal® 2K	53
Turcon® Stepseal® K	61
Turcon® Double Delta®	69
Turcon® Variseal® M2	77
Zurcon® U-Cup PUA	83
Zurcon® Wynseal	93
POLYPAC® PHD/P	99
Compact Seal DAS Type A/B - POLYPAC® DBM	105
Zurcon® Compact Seals PU DAS - POLYPAC® EUD	113
Rubber Fabric Compact Seal POLYPAC® DUOPAC DPS/DPC	119
POLYPAC® Veepac CH/G1	127
POLYPAC® Selemaster DSM	131
Non Standard Seals	137

■ Choice of the Sealing Element

Sealing elements have a decisive influence on the design, function and service life of hydraulic and pneumatic cylinders and systems.

This applies equally to the piston seals where leak tightness, resistance to wear and gap extrusion, resistance to process media, resistance to high and low temperatures, low friction, compact form and simple installation are demanded in order to meet the requirements of industry for a functional sealing solution.

The significance of these parameters and their limits is generally dependent on the requirements of the specific application. B+S has therefore developed a complete range of seals which, due to their optimized geometries and designs and the use of high-quality materials such as Turcon[®] and Zurcon[®], satisfy the technical and economic demands of the industry in full.

In order to be in a position to select the most appropriate seal type and material, it is necessary to first define all the desired functional parameters. Table I can then be used to make an initial selection of seals according to the specific requirements of the application.

The second column of the table contains the number of the page on which further general information together with specific design and installation instructions on the particular seal type and materials (or material combinations with multi-element seals, e.g. Turcon[®] Glyd Ring[®] T) can be found.

Furthermore, attention is drawn to the quality of the mating surface. We recommend that the limits specified there be observed, as they have a decisive influence on the functionality and service life of the system.

The final choice of seal type and material must also take account of the detailed information on the seal elements.

Please do not hesitate to contact our Technical Department for further information on specific applications and special technical questions.

This Catalogue is a compilation of the preferred product ranges of Busak+Shamban, Sealing Parts and POLYPAC. All similar products are technically equivalent but availability and pricing may vary. For further information please contact your local Busak+Shamban company.

Note on Ordering

All multi-element standard piston seals, e.g. Glyd Ring[®] T, are generally supplied as complete seal sets. The supply includes the seal and matching elastomer energizing elements. The O-Ring does not have to be ordered separately. It is also possible to use other O-Ring materials from our O-Ring catalogue. In this case, please order the seal ring and O-Ring separately. We will inform you the sizes of the O-Ring on request.

When ordering the seal ring separately, it is then not necessary to mention the "O-Ring material code" in the Order No. shown in the ordering examples.







Older designs of seals no longer contained in this catalogue naturally continue to be available (see chapter Non Standard Seals). For all new applications, however, we recommend the use of the seal types and preferred sizes (ISO series, wherever possible) listed in this catalogue.

Other combinations of Turcon[®] materials and special designs can be developed and supplied for special applications in all intermediate sizes up to 2.700 mm diameter, provided there is sufficient demand.

The sizes contained in this catalogue are generally available from stock or can be supplied at short notice. We reserve the right to modify our supply programme.

Piston Seals

Table I Selection Criteria for Piston Seals







Seal		Application	Standard	Size Range	Action		Technical Data*			Recommended Seal Material		
Type	Page				ISO/DIN	mm	Single	Double	Temp. Range**		Speed	Pressure
		Field of Application					°C	m/s	MPa max.			
		Light	Medium	Heavy								
 Turcon® Glyd Ring®	15	Mobil hydraulic Machine tools Injection moulding machines Presses	•	•	•	7425/1	8-2700	X	-45/ +200	15	60	Turcon® T46
											60	Turcon® T29
											20	Turcon® T05
											8-2300	-45/ +100
 Turcon® Glyd Ring®T	23	Mobile hydraulics Standard cylinders Machine tools Injection moulding machines Presses Automotive industry	•	•	•	7425/1	8-2700	X	-45/ +200	15	60	Turcon® T46
							25				Turcon® T40	
							8-2300				-45/ +100	2
 Turcon® AQ-Seal® 5	31	Mobile hydraulic Holding cylinders Piston accumulators	•	•	•	-	40-700	X	-45/ +200	3	60	Turcon® T46
											60	Turcon® T10
 Turcon® AQ-Seal®	39	Standard cylinders Piston accumulators	•	•	•	7425/1	15-700	X	-45/ +200	2	40	Turcon® T46
											40	Turcon® T10
 Compact Seal PHD	47	Mobile hydraulic Excavators Heavy duty hydraulic cylinders	•	•	•	-	50-180	X	-45/ +135	1.5	40	PTFE Bronze + NBR + POM
 Turcon® Stepseal® 2K	53	Mobile hydraulics Standard cylinders Machine tools Injection moulding machines Presses	•	•	•	7425/1	8-2700	X	-45/ +200	15	70	Turcon® T46
							70				Turcon® T29	
							8-2300				-45/ +100	2
 Turcon® Stepseal® K	61	Mobile hydraulics Standard cylinders Machine tools Injection moulding machines Presses	•	•	•	7425/1	8-2700	X	-45/ +200	15	60	Turcon® T46
							60				Turcon® T29	
							8-2300				-45/ +100	2

* The data below are maximum values and cannot be used at the same time. The max. pressure depends on temperature and gap dimension.

** Temperature Range is depending on choice of elastomer material and Media.

In the case of Turcon® seals in unpressurized applications in temperatures below 0°C please contact our application engineers for assistance !



Piston Seals

Seal		Application	Standard	Size Range	Action		Technical Data*			Recommended Seal Material	
Type	Page				Field of Application	ISO/DIN	mm	Single	Double		Temp. Range**
								°C	m/s	MPa max.	
 Turcon® Double Delta®	69	Machine tools Handling devices/ manipulators Valves Chemical industry		-	5-2700		X	-45/ +200	15	20	Turcon® T05
										35	Turcon® T46
										25	Turcon® T24
 Turcon® Variseal®M2	77	High and low temperatures Aggressive media Foodstuffs	3771 MIL-G- 5514F	6-2700		X	-70/ +260	15	45	Turcon® T40	
									20	Turcon® T05	
 Zurcon® U-Cup PUA	83	Presses Lift platforms Aftermarket	-	16-250		X	-35/ +110	0.5	40	Zurcon® Z20	
 Zurcon® Wynseal	93	Standard cylinders Mobile hydraulics	7425/1	12-300		X	-35/ +110	0.5	25	Zurcon® Z20 + NBR	
									40	Zurcon® Z05 + NBR WU9LN	
 Compact Seal PHD/P	99	Mobile hydraulic Excavators Heavy duty hydraulic cylinders	-	50-180		X	-35/ +110	0.5	40	Zurcon® Z20 + NBR + POM	
 Compact Seal DAS/DBM	105	Standard cylinders Holding cylinders Agricultural machinery	6547	20-250		X	-30/ +100	0.5	35	NBR + TPE + POM	
 Compact Seal PCC/PCG	113	Truck cranes Mini excavators Heavy duty cylinders	6547	40-270		X	-35/ +110	0.5	40	Zurcon® Z20 + NBR + POM	

* The data below are maximum values and cannot be used at the same time. The max. pressure depends on temperature and gap dimension.

** Temperature Range is depending on choice of elastomer material and Media.

Piston Seals

Seal		Application	Standard	Size Range	Action		Technical Data*			Recommended Seal Material		
Type	Page				Field of Application	ISO/DIN	mm	Single	Double		Temp. Range**	Speed
								°C	m/s	MPa max.		
 Duopac DPS	119	Mining equipment Presses Steel mills Water hydraulic			-	40-250		X	-30/ +130	0.5	40	Fabric reinforced NBR + POM
 Veepac CH/G1	127	Mining equipment Excavators Steel mills Presses			-	40-250	X		-30/ +200	0.5	40	Fabric reinforced Rubber
 Selemaster DSM	131	Mining equipment Excavators Steel mills Presses			-	45-360		X	-30/ +130	0.5	70	Fabric reinforced Rubber + POM

* The data below are maximum values and cannot be used at the same time. The max. pressure depends on temperature and gap dimension.

** Temperature Range is depending on choice of elastomer material and Media.

Piston Seals

Design Instructions

Lead in chamfers

Piston seals are always fitted with an interference fit. In order to avoid damage during installation, lead-in chamfers and rounded edges must be provided on the cylinder barrel (Figure 1). If this is not possible for design reasons, a separate installation tool must be used.

The minimum lead-in chamfer depends on the profile size of the seal and can be seen from the following tables.

Additionally it is recommended that the diameter increase ΔD exceeds $0.015 \times$ bore diameter.

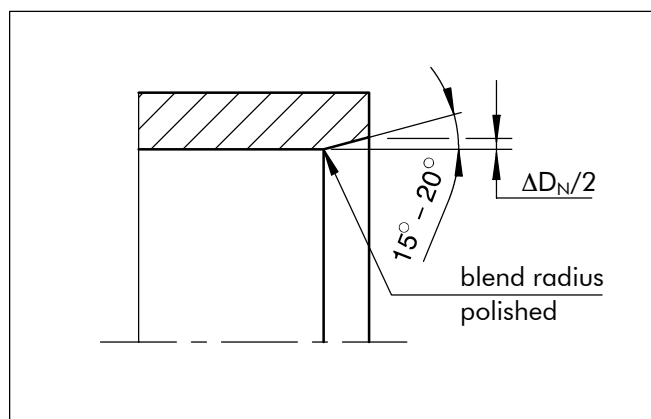

Figure 1 Lead-in chamfer

Table II Elastomer Energized Seals

Lead-in Chamfer Diameter increase ΔD_N min.	Groove Width L1*
1.1	2.2
1.4	3.2
1.9	4.2
2.7	6.3
3.5	8.1
4.0	9.5
5.5	13.8

* The groove width can be found in table "Installation dimensions" for Turcon® Glyd Ring® T, Turcon® AQ-Seal® 5, Turcon® Stepseal® K, Zurcon® Wynseal and Turcon® AQ-Seal®.

Table III Compact Seal and Variseal®

Lead-in Chamfer Diameter increase ΔD_N min.	Compact Seal Groove Depth*	Turcon® Variseal® M2 Series
1.1	3.5	
1.1	4.0	
1.4	5.0	
2.2	7.5	PVA0
2.7	10.0	PVA1,PVA2
3.5	12.5	
4.0	15.0	PVA3
5.5	20.0	
6.5		PVA4
9.5		PVA5

* The groove depth is calculated as $(D - D1)/2$. The dimensions for D and D1 can be found in the tables "Installation dimensions", from chapter Compact Seal DAS and DBM.

Table IV Double Delta®

Lead-in Chamfer* Diameter increase ΔD_N min.	O-Ring Cross Section** d_2	
1.1	1.78	-
1.4	2.40	2.62
1.9	3.00	3.53
2.7	5.33	5.70
3.5	7.00	8.40

* Though not less than 1.5 % of service diameter (bore/rod diameter).

**The O-Ring cross section d_2 can be found in the in the appropriate table "Installation Dimensions", from chapter Double Delta®.

Piston Seals

Surface Roughness DIN EN ISO 4287

The functional reliability and service life of a seal depend to a very great extent on the quality and surface finish of the mating surface to be sealed.

Scores, scratches, pores, concentric or spiral machining marks are not permitted. Higher demands must be made on the surface finish of dynamic surfaces than of static mating surfaces.

The characteristics most frequently used to describe the surface microfinish R_a , R_z and R_{max} are defined in DIN EN ISO 4287. These characteristics alone, however, are not sufficient for assessing the suitability in seal technology. In addition the material contact area of the surface roughness profile R_{mr} in accordance with DIN EN ISO 4287 should be demanded. The significance of this surface specification is illustrated in Fig. 2. It shows clearly that specification of R_a and R_z alone does not describe the surface roughness profile accurately enough for the seal technology and is thus not sufficient for assessing the suitability. The material contact area R_{mr} is essential for assessing surfaces, as this parameter is determined by the specific surface roughness profile. This in turn is directly dependent on the machining process employed.

Busak+Shamban recommends that the following surface finishes be observed:

Table V Surface Roughness

Surface Roughness μm			
Parameter	Mating Surface		Groove Surface
	Turcon [®] Materials	Zurcon [®] and Rubber	
R_{max}	0.63 - 2.50	1.00 - 4.00	< 16.0
R_z DIN	0.40 - 1.60	0.63 - 2.50	< 10.0
R_a	0.05 - 0.20	0.10 - 0.40	< 1.6

The material contact area R_{mr} should be approx. 50 to 70%, determined at a cut depth $c = 0.25 \times R_z$, relative to a reference line of C_{ref} 5%.



Surface profile	R_a	R_z	R_{mr}
closed profile form 	0.1	1.0	70%
open profile form 	0.2	1.0	15%

Figure 2 Profile forms of surfaces

Figure 2 shows two surface profiles, both of which exhibit nearly the same value for R_z in the test procedure. The difference becomes obvious only when the material contact area of the surface roughness profiles are compared. These show that the upper roughness profile with $R_{mr} = 70\%$ has the better seal/mating surface ratio.

Piston Seals

■ Installation of Piston Seals

General Installation Instructions

The following points should be observed before installation of the seals:

- Ensure the cylinder tube has a lead in chamfer; if not, use an installation sleeve
- Deburr and chamfer or round sharp edges, cover the tips of screw threads
- Remove machining residues such as chips, dirt and other foreign particles and carefully clean all parts
- The seals can be installed more easily if they are greased or oiled. Attention must be paid to the compatibility of the seal materials with these lubricants. Use only grease without solid additives (e.g. molybdenum disulphide or zinc sulphide).
- Use no sharp-edged installation tools

Installation in Split Grooves

Installation in split grooves is simple. The sequence of installation corresponds to the configuration of the seal. Individual seal elements must not be allowed to twist. During final installation (installation of the piston in the cylinder), elastomer or spring-preloaded seals must be sized. The corresponding cylinder barrel can be used for this purpose, provided it has a long lead-in chamfer. Alternatively, a sizing sleeve should be used.

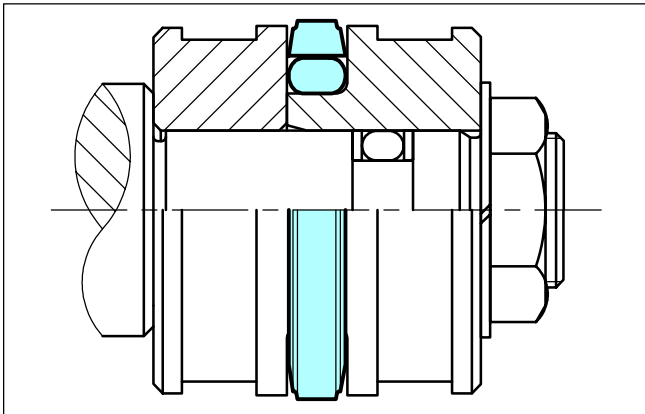

Figure 3 Installation in a split groove

Installation in Closed Grooves

- Without installation aids

Observing the instructions in the chapter "General installation instructions", installation of Compact Seal and Wynseal seal elements in closed grooves is relatively simple.

For Turcon® and Zurcon® seals, the use of installation aids is recommended. If installation has to be performed without installation aids, however, the following points should be observed:

Turcon® seals can be installed more easily by heating in oil, water or using a hot air fan to approx. 80°C to 100°C (expanding and then shrinking back to the original form).

Use no sharp edged tools to expand the seal rings.

Sizing of the seal ring is achieved with a separate sizing sleeve, or with the cylinder tube provided this has lead-in chamfers equivalent to 2 x the values from Table II.

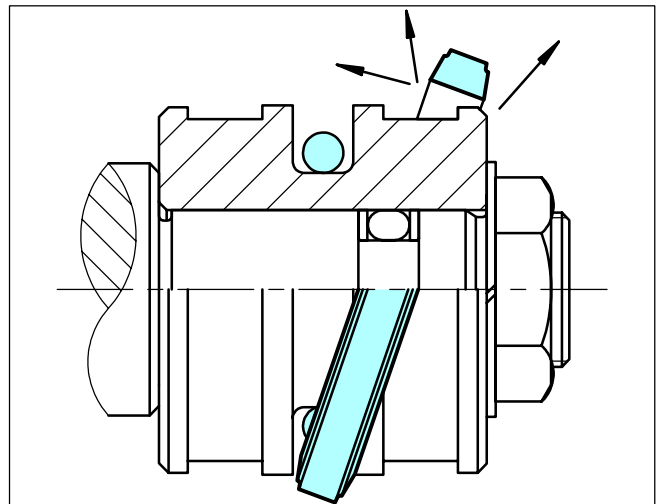

Figure 4 Fitting the seal ring onto the O-Ring in the groove

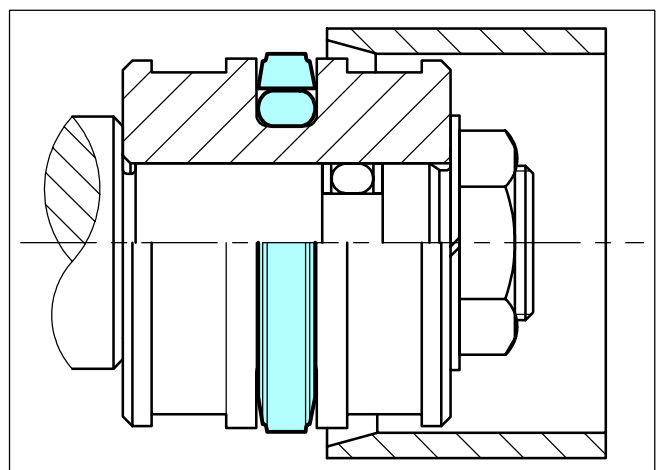

Figure 5 Sizing of the installed seal

Piston Seals

Installation in Closed Grooves

- With installation aids

Use of a three-piece installation tool is recommended for the series production installation of Turcon® and Zurcon® seal elements. The tool consists of:

- Installation sleeve
- Expanding sleeve
- Sizing sleeve

All these parts should be made of a polymer material (e.g. PA6) with good sliding characteristics and low abrasiveness to avoid damage to the seals.

In view of the wide range of sizes and the application-specific installation conditions, these installation tools cannot be supplied as standard by Busak+Shamban.

On request, however, we will gladly provide specimen drawings to allow you to manufacture these tools.

The sequence of installation is illustrated in Fig. 6 to 8. Note, however, that the installation of Turcon® seal elements should be performed quickly in order to ensure optimum recovery of the seal ring.

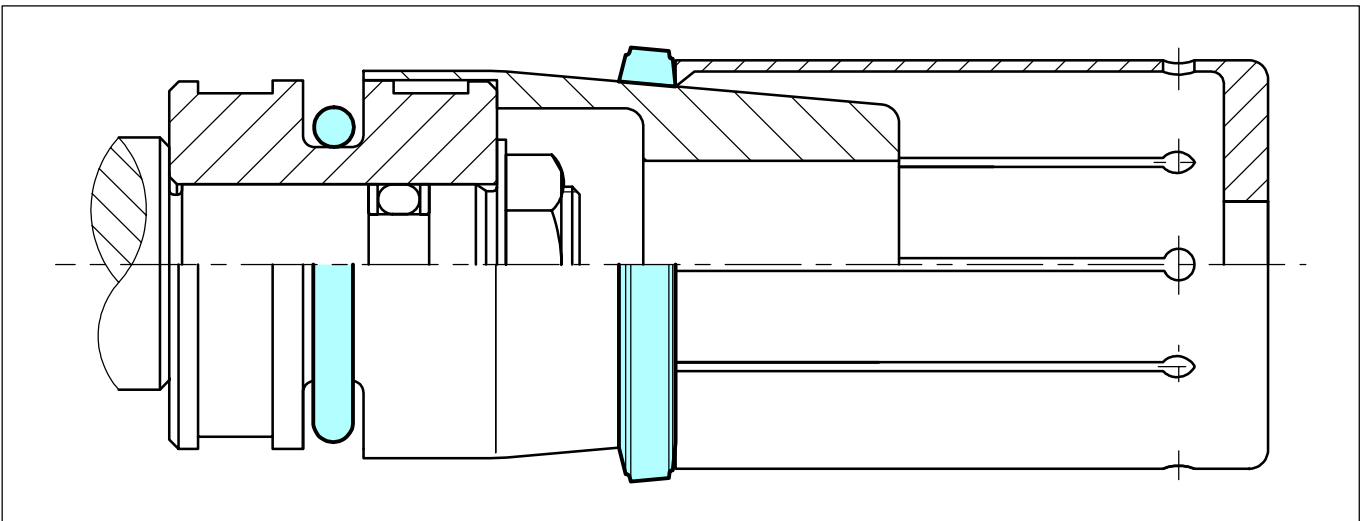

Figure 6 Expanding the Turcon® or Zurcon® sealing element using an expanding sleeve over the installation sleeve

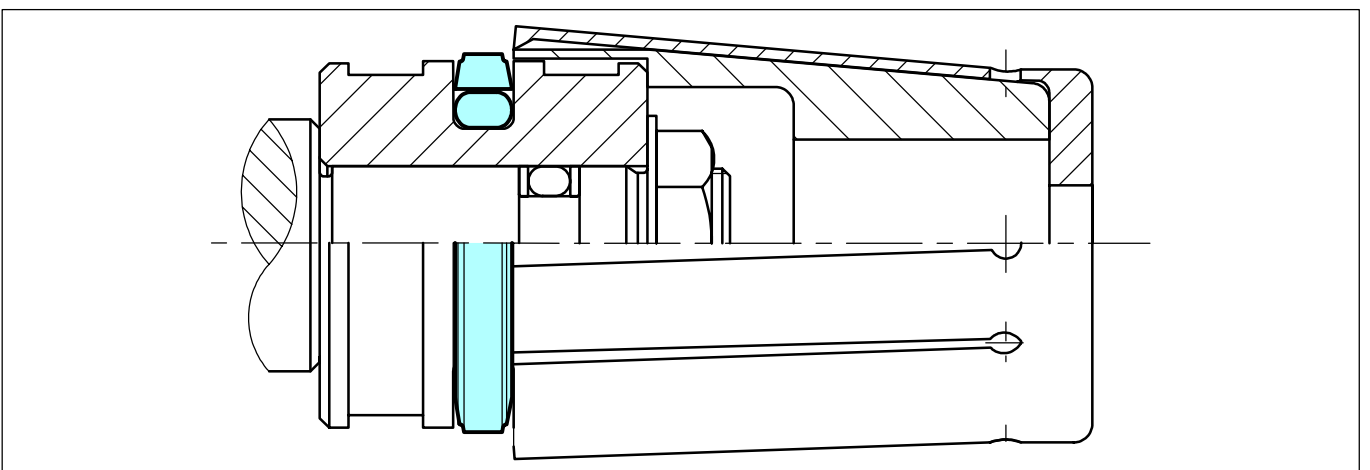

Figure 7 Sealing element after snapping into the groove

Piston Seals

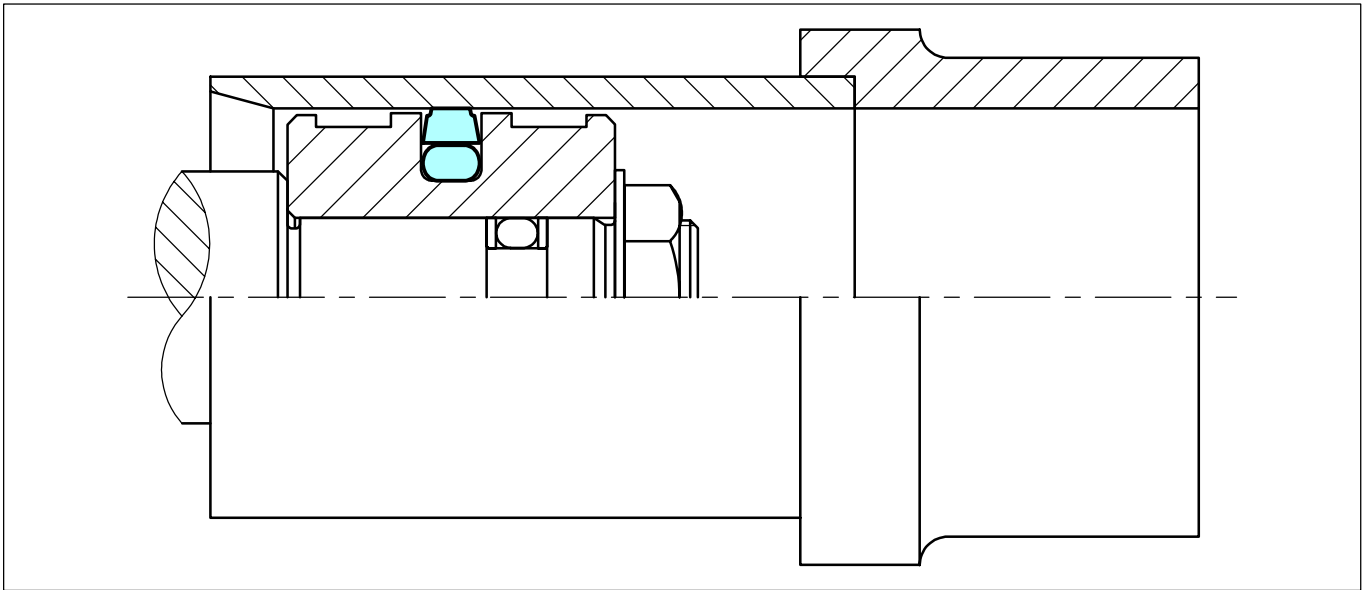

Figure 8 Sizing the sealing element with sizing sleeve

Installation of Turcon® Double Delta®

Installation in closed grooves is possible from 8 mm bore diameter. For diameters smaller than 50 mm a loading mandrel (Fig. 9) is recommended. After installation the seal must be calibrated, this may be done with the lead-in chamfer of the cylinder tube or by means of a separate calibration sleeve.

- Turcon® piston seals can be installed more easily by heating to approx. 80°C to 100°C (expanding and then shrinking back to the original form).

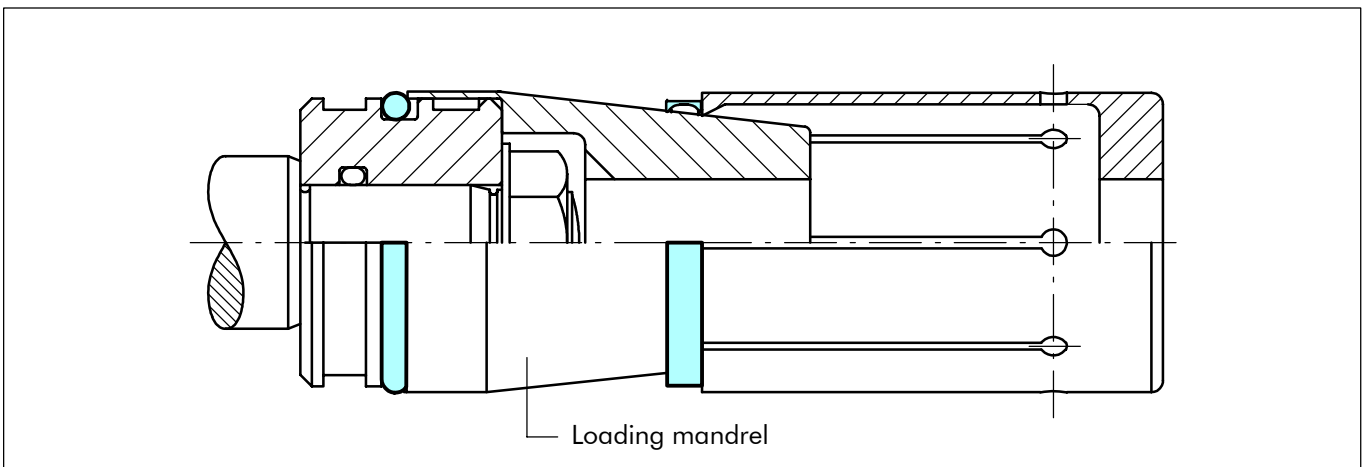

Figure 9 Installation in a closed groove

Piston Seals

Installation of Spring Energized Seals

Turcon® Variseal® seals should preferably be installed in split grooves. Installation in half-open grooves is possible with a snap fitting. Figure 10 shows the design of the groove.

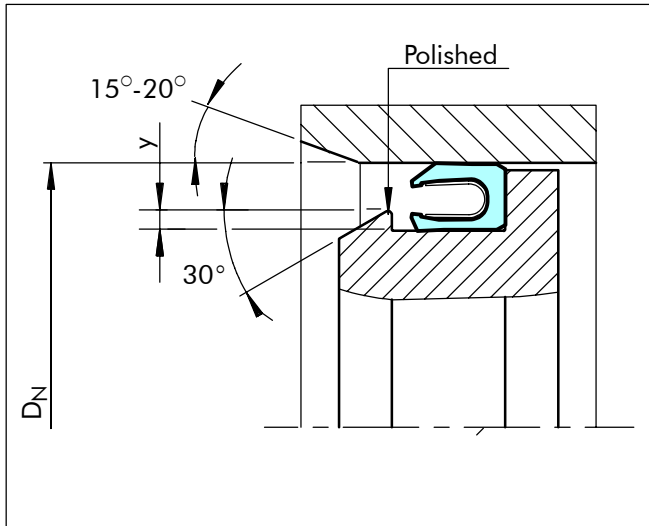

Figure 10 Installation in a half-open groove

Table VI Installation in Half-Open Grooves

Series No.	D_N min.	Y_{min} .
PVA0	15.0	0.4
PVA1	21.0	0.6
PVA2	25.0	0.7
PVA3	30.0	0.8
PVA4	45.0	0.9
PVA5	65.0	0.9

For further details, see chapter Turcon® Variseal®.

In exceptional cases or with existing designs, an installation in closed grooves is also possible. The details in Table VII should be regarded as guide values for installation.

Table VII Installation in closed grooves

Series No.	D_N min.
PVA0	35.0
PVA1	50.0
PVA2	70.0
PVA3	105.0
PVA4	140.0
PVA5	220.0

Installation of the Compact Seal

The Compact Seal can be installed in one-piece or split pistons. On one-piece pistons, the inner rubber-elastic sealing element is first installed in the middle of the groove diameter by expanding over the piston. Then the cut Back-up Ring are fitted on both sides of the sealing element and then the two cut guide rings are installed.

On split pistons the individual parts are installed in the following order: Guide ring, Back-up Ring, sealing element, Back-up Ring, Guide ring.

Before installation all seal parts, including piston and cylinder, should be oiled or greased.

Piston Seals

TURCON[®] GLYD RING[®]

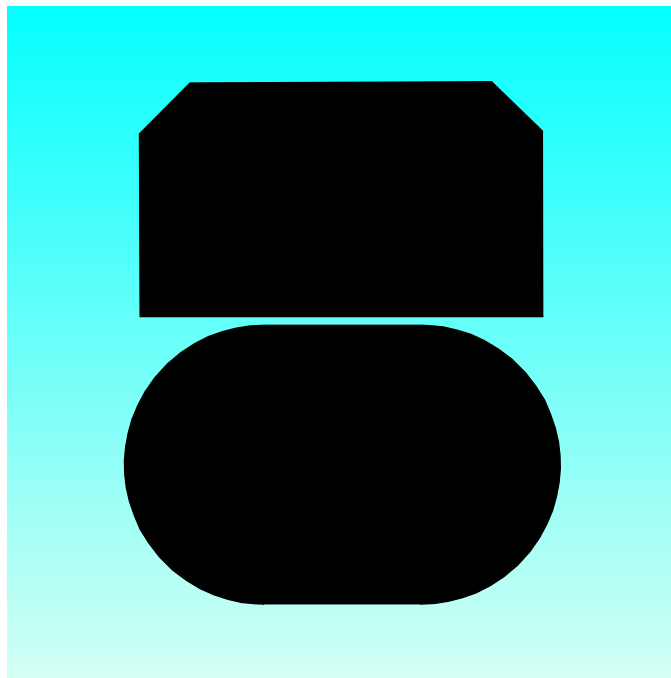

- Double Acting -

- Rubber Energised Plastic Faced Seal -

- Material -

- Turcon[®], Zurcon[®] and Elastomer -





■ Turcon® Glyd Ring®

Description

Successfully used for decades, the Tucon® Glyd Ring® is a very effective and reliable low frictional seal. It is particularly suitable as a piston seal in both high and low pressure systems.

The double acting Tucon® Glyd Ring® is a combination of a Turcon based slipper seal and an energising O-Ring. It is produced with an interference fit which together with the squeeze of the O-Ring ensures a good sealing effect even at low pressure. At higher system pressures, the O-Ring is energised by the fluid, pushing the Turcon® Glyd Ring® against the sealing face with increased force.

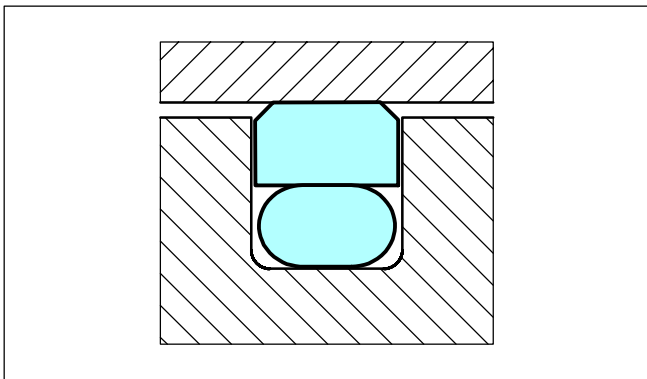

Figure 11 Turcon® Glyd Ring®

The geometry of the Tucon® Glyd Ring® ensures a good static sealing and allows the lubricating hydrodynamic oil film to be build under the seal in reciprocating applications.

Notches

To assure that a rapid energising of the seal takes place at sudden changes of pressure and direction of motion, radial "notches" are machined on both sides of the seal.

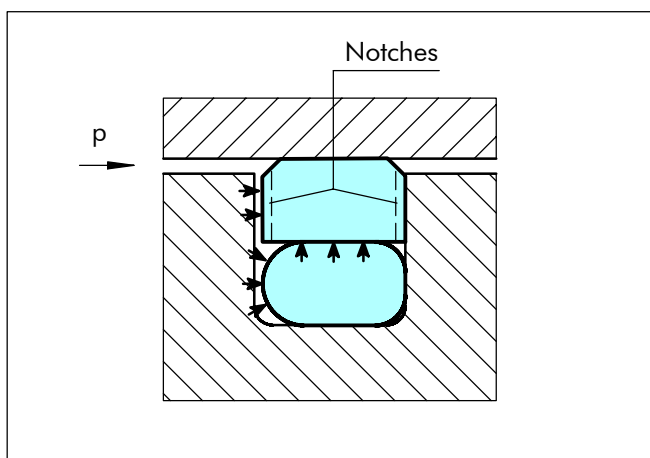

Figure 12 Turcon® Glyd Ring® with notches

Notches are standard on the following series and diameters

PG 42 for bore dia. > 30mm

PG 44 for bore dia. > 20mm

PG 46 for bore dia. > 40mm

Advantages

- No stick-slip effect when starting for smooth operation
- Minimum static and dynamic friction coefficient for a minimum energy loss and operating temperature
- Suitable for non lubricating fluids depending on seal material for optimum design flexibility
- High wear resistance ensures long service life
- Installation grooves acc. to ISO 7425/1
- No adhesive effect to the mating surface during long period of inactivity or storage
- Suitable for most hydraulic fluids in relation with most modern hardware materials and surface finish depending on material selected.
- Suitable for new environmentally safe hydraulic fluids
- Available for all cylinder diameters up to 2.700 mm.

Application Examples

Over several decades the Turcon® Glyd Ring® has been successfully implemented in a lot of applications as double acting Piston seals of hydraulic components such as:

- Injection moulding machines
- Machine tools
- Presses
- Excavators
- Forklifts & handling machinery
- Agriculture equipment
- Valves for hydraulic & pneumatic circuits.



Technical Data

Operating conditions:

The Turcon[®] Glyd Ring[®] is recommended for reciprocating (with a length of stroke at least twice the groove width) and helical movements.

Pressure: up to 80MPa

Speed: up to 15m/s

Frequency: up to 5 Hz.

Temperature: -45°C to +200°C *)
(depending on O-Ring Material)

Media: Mineral oil based hydraulic fluids, barely flammable hydraulic fluids, environmentally safe hydraulic fluids (biological degradable oils), water, air and others. Depending on the O-Ring material compatibility.

Clearance: the maximum permissible radial clearance S_{max} is shown in the table IX, as a function of the operating pressure and functional diameter.

Important Note:

The above data are maximum values and cannot be used at the same time. e.g. the maximum operating speed depends on material type, pressure, temperature and gap value. Temperature range also dependent on medium.

*) In the case of unpressurized applications in temperatures below 0°C please contact our application engineers for assistance !

Materials

Standard Application:

- For hydraulic components in mineral oils containing zinc or medium with good lubricating performance.

Turcon[®] seal: Turcon[®] T 46

Energiser: O-Ring NBR 70 shore A or FKM 70 Shore A depending on the temperature

Set reference. T46N or T46V

Special Application:

- Short stroke movements, non-lubricating fluids or pneumatic applications require self-lubricating sealing materials. Therefore we recommend:

Turcon[®] Seal: Turcon[®] T29

Energiser: O-Ring NBR 70 Shore A or FKM 70 Shore A depending on the temperature

Set reference: T29N or T29V

- If low friction coefficient is required, we recommend:

Turcon[®] Seal: Turcon[®] T 05

Energiser: O-Ring NBR 70 Shore A or FKM 70 Shore A depending on the temperature.

For special requirements other elastomers are available on request

Set reference: T05N or T05V

If rougher surface finish must be sealed, we recommend:

Zurcon[®] Seal: Zurcon[®] Z51

Energiser: O-Ring NBR 70 Shore A

Set reference: Z51N



Table VIII Turcon® and Zurcon® Materials for Glyd Ring®

Material, Applications, Properties	Code	O-Ring Material	Code	O-Ring Operating Temp.* °C	Mating Surface Material	MPa max.
Turcon® T46 Standard material for hydraulics, high compressive strength, good sliding and wear properties, good extrusion resistance, BAM tested. Bronze filled Colour: Greyish to dark brown	T46	NBR - 70 Shore A	N	-30 to +100	Steel tubes Steel, hardened Cast iron	60
		NBR - Low temp. 70 Shore A	T	-45 to +80		
		FKM - 70 Shore A	V	-10 to +200		
Turcon® T08 Very high compressive strength, very good extrusion resistance. High bronze filled Colour: Light to dark brown	T08	NBR - 70 Shore A	N	-30 to +100	Steel tubes Steel, hardened Cast iron	80
		NBR - Low temp. 70 Shore A	T	-45 to +80		
		FKM - 70 Shore A	V	-10 to +200		
Turcon® T40 For all lubricating and non-lubricating hydraulic fluids, water hydraulic, soft mating surfaces. Carbon fibre filled Colour: Grey	T40	NBR - 70 Shore A	N	-30 to +100	Steel Cast iron Stainless steel Aluminium Bronze Alloys	25
		NBR - Low temp. 70 Shore A	T	-45 to +80		
		FKM - 70 Shore A	V	-10 to +200		
		EPDM-70 Shore A	E**	-45 to +145		
Turcon® T29 For all lubricating and non-lubricating hydraulic fluids, hydraulic oils without zinc, soft mating surfaces, good extrusion resistance. High carbon fibre filled Colour: Grey	T29	NBR - 70 Shore A	N	-30 to +100	Steel Cast iron Stainless steel Aluminium Bronze	60
		NBR - Low temp. 70 Shore A	T	-45 to +80		
		FKM - 70 Shore A	V	-10 to +200		
		EPDM-70 Shore A	E**	-45 to +145		
Turcon® T05 For all lubricating hydraulic fluids, hard mating surfaces, very good sliding properties, low friction. Colour: Turquoise	T05	NBR - 70 Shore A	N	-30 to +100	Steel tubes Steel, hardened	20
		NBR - Low temp. 70 Shore A	T	-45 to +80		
		FKM - 70 Shore A	V	-10 to +200		
Turcon® T42 For all lubricating and non-lubricating hydraulic fluids, good chemical resistance, good dielectric properties. Glass fibre filled + MoS ₂ Colour: Grey to blue	T42	NBR - 70 Shore A	N	-30 to +100	Steel tubes Steel, hardened Cast iron	30
		NBR - Low temp. 70 Shore A	T	-45 to +80		
		FKM - 70 Shore A	V	-10 to +200		
Turcon® T10 For oil hydraulic and pneumatic, for all lubricating and non-lubricating fluids, high extrusion resistance, good chemical resistance, BAM tested. Carbon, graphite filled Colour: Black	T10	NBR - 70 Shore A	N	-30 to +100	Steel Stainless steel	60
		NBR - Low temp. 70 Shore A	T	-45 to +80		
		FKM - 70 Shore A	V	-10 to +200		
		EPDM-70 Shore A	E**	-45 to +145		
Zurcon® Z51*** For lubricating hydraulic fluids, high abrasion resistance, high extrusion resistance, limited chemical resistance. Cast polyurethane Colour: Yellow to light-brown	Z51	NBR - 70 Shore A	N	-30 to +100	Steel Steel, hardened Cast iron Ceramic coating Stainless steel	80
		NBR - Low temp. 70 Shore A	T	-45 to +80		
Zurcon® Z80 For lubricating and non-lubricating hydraulic fluids, high abrasion resistance, very good chemical resistance, limited temperature resistance. Ultra high molecular weight polyethylen Colour: White to off-white	Z80	NBR - 70 Shore A	N	-30 to +80	Steel Stainless steel Aluminium Bronze Ceramic coating	40
		NBR - Low temp. 70 Shore A	T	-45 to +80		

* The O-Ring Operation Temperature is only valid in mineral hydraulic oil. BAM: Tested by "Bundes Anstalt Materialprüfung, Germany".

Highlighted materials are standard. **Material not suitable for mineral oils. *** max. Ø 2300 mm



■ Installation Recommendations

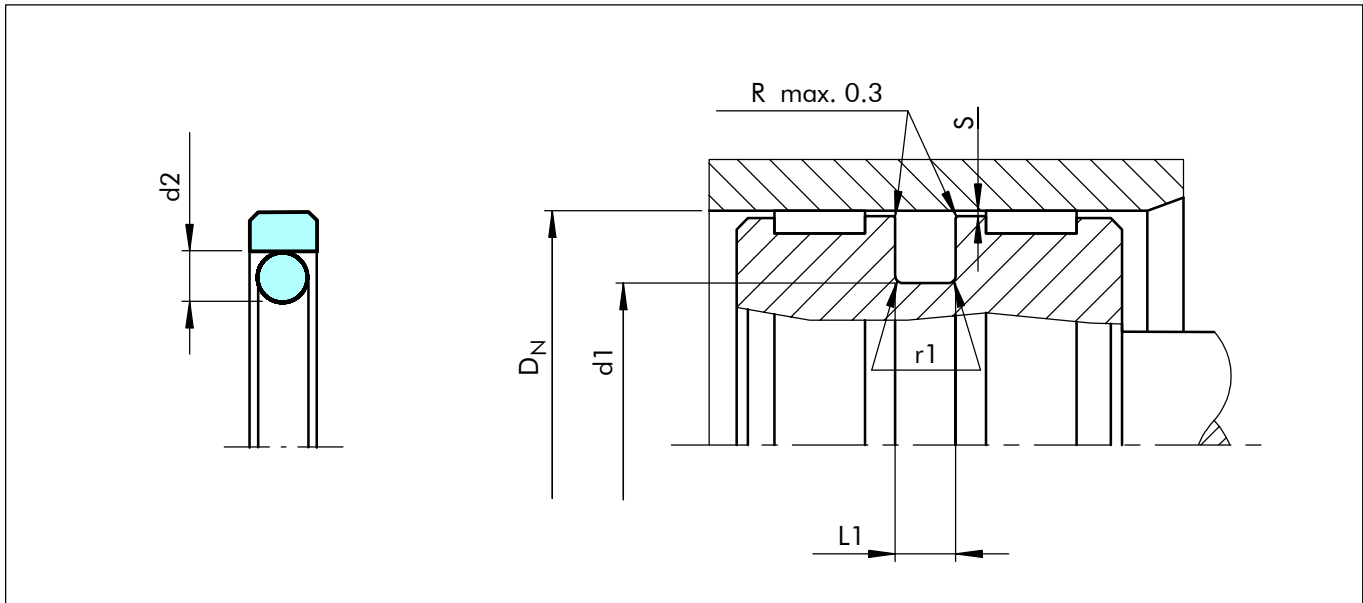

Figure 13 Installation drawing

Table IX Installation Dimension

Bore Diameter D_N H9			Groove Diameter	Groove Width	Radius	Radial Clearance			O-Ring Cross-Section d_2
Series No. PG 44	Series No. PG 46	Series No. PG 42				S max.*			
Standard Application	Light Application	Heavy-Duty Application	d_1 h9	$L_1 + 0.2$	r_1	10 MPa	20 MPa	40 MPa	
8 - 14.9	15 - 39.9	-	$D_N - 4.9$	2.2	0.4	0.30	0.20	0.15	1.78
15 - 39.9	40 - 79.9	-	$D_N - 7.5$	3.2	0.6	0.40	0.25	0.15	2.62
40 - 79.9	80 - 132.9	15 - 39.9	$D_N - 11.0$	4.2	1.0	0.40	0.25	0.20	3.53
80 - 132.9	133 - 329.9	40 - 79.9	$D_N - 15.5$	6.3	1.3	0.50	0.30	0.20	5.33
133 - 329.9	330 - 669.9	80 - 132.9	$D_N - 21.0$	8.1	1.8	0.60	0.35	0.25	7.00
330 - 669.9	670 - 999.9	133 - 329.9	$D_N - 24.5$	8.1	1.8	0.60	0.35	0.25	7.00
670 - 999.9	-	330 - 669.9	$D_N - 28.0$	9.5	2.5	0.70	0.50	0.30	8.40
> 1000			$D_N - 38.0$	13.8	3.0	1.00	0.70	0.60	12.00

* At pressures > 40 MPa use diameter tolerance H8/f8 (bore/piston) in area of the seal.

Ordering Example

Turcon[®] Glyd Ring[®], complete with O-Ring, standard application, Series PG44 (from Table IX).

Bore diameter: $D_N = 80.0$ mm

Part No.: PG4400800 (from Table X)

Select the material from Table VIII. The corresponding code numbers are appended to the Part No. Preferred Series (Table X).

Together they form the order number. The order number for all intermediate sizes not shown in Preferred Series (Table X) can be determined following the example opposite.

** For diameters ≥ 1000.0 mm multiply only by factor 1.

Example: PG44 for diameter 1200.0 mm.

Order no.: PG44X1200 - T46N.

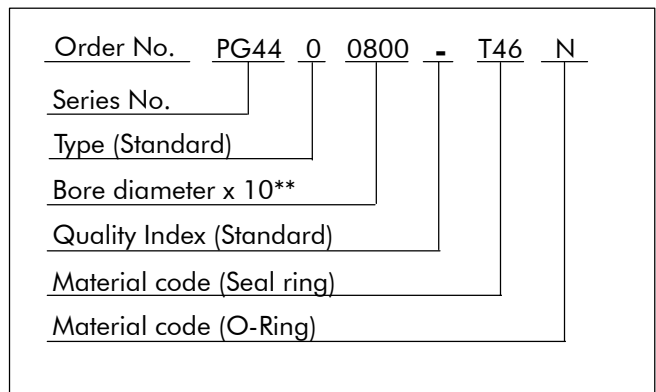



Table X Installation dimensions/Part No.

Bore Dia.	Groove Dia.	Groove Width	Part No.	O-Ring Dimensions
D _N H9	d ₁ h9	L ₁ +0.2		
8.0	3.1	2.2	PG4400080	2.90 x 1.78
10.0	5.1	2.2	PG4400100	4.80 x 1.8
12.0	7.1	2.2	PG4400120	6.70 x 1.8
14.0	9.1	2.2	PG4400140	8.75 x 1.8
15.0	7.5	3.2	PG4400150	7.59 x 2.62
16.0	11.1	2.2	PG4600160	10.82 x 1.78
16.0	8.5	3.2	PG4400160	7.59 x 2.62
18.0	13.1	2.2	PG4600180	12.42 x 1.78
18.0	10.5	3.2	PG4400180	9.19 x 2.62
19.05	11.55	3.2	PG4400190	10.77 x 2.62
20.0	15.1	2.2	PG4600200	14.00 x 1.78
20.0	12.5	3.2	PG4400200	12.37 x 2.62
21.0	13.5	3.2	PG4400210	12.37 x 2.62
22.0	17.1	2.2	PG4600220	17.17 x 1.78
22.0	14.5	3.2	PG4400220	13.94 x 2.62
24.0	16.5	3.2	PG4400240	15.54 x 2.62
25.0	20.1	2.2	PG4600250	18.77 x 1.78
25.0	17.5	3.2	PG4400250	17.12 x 2.62
25.0	14.0	4.2	PG4200250	13.87 x 3.53
25.4	20.5	2.2	PG4600254	17.12 x 2.62
28.0	20.5	3.2	PG4400280	20.29 x 2.62
30.0	22.5	3.2	PG4400300	21.89 x 2.62
32.0	27.1	2.2	PG4600320	26.70 x 1.78
32.0	24.5	3.2	PG4400320	23.47 x 2.62
32.0	21.0	4.2	PG4200320	20.22 x 3.53
35.0	27.5	3.2	PG4400350	26.64 x 2.62
35.0	24.0	4.2	PG4200350	23.40 x 3.53
36.0	28.5	3.2	PG4400360	28.24 x 2.62
38.0	30.5	3.2	PG4400380	29.82 x 2.62
40.0	32.5	3.2	PG4600400	31.42 x 2.62
40.0	29.0	4.2	PG4400400	28.17 x 3.53
42.0	31.0	4.2	PG4400420	29.75 x 3.53
44.45	36.95	3.2	PG4600444	36.17 x 2.62
45.0	34.0	4.2	PG4400450	32.92 x 3.53
48.0	37.0	4.2	PG4400480	36.09 x 3.53
50.0	42.5	3.2	PG4600500	40.94 x 2.62
50.0	39.0	4.2	PG4400500	37.70 x 3.53
50.0	34.5	6.3	PG4200500	32.69 x 5.33
50.8	43.3	3.2	PG4600508	42.52 x 2.62
50.8	39.8	4.2	PG4400508	37.70 x 3.53
52.0	41.0	4.2	PG4400520	40.87 x 3.53
53.0	42.0	4.2	PG4400530	40.87 x 3.53

Bore Dia.	Groove Dia.	Groove Width	Part No.	O-Ring Dimensions
D _N H9	d ₁ h9	L ₁ +0.2		
55.0	44.0	4.2	PG4400550	44.04 x 3.53
57.0	46.0	4.2	PG4400570	44.04 x 3.53
58.0	47.0	4.2	PG4400580	47.22 x 3.53
60.0	49.0	4.2	PG4400600	47.22 x 3.53
62.0	51.0	4.2	PG4400620	50.39 x 3.53
63.0	52.0	4.2	PG4400630	50.39 x 3.53
63.0	47.5	6.3	PG4200630	46.99 x 5.33
65.0	54.0	4.2	PG4400650	53.57 x 3.53
68.0	57.0	4.2	PG4400680	56.74 x 3.53
70.0	59.0	4.2	PG4400700	56.74 x 3.53
70.0	54.5	6.3	PG4200700	53.34 x 5.33
75.0	64.0	4.2	PG4400750	63.09 x 3.53
75.0	59.5	6.3	PG4200750	56.52 x 5.33
80.0	69.0	4.2	PG4600800	66.27 x 3.53
80.0	64.5	6.3	PG4400800	62.87 x 5.33
80.0	59.0	8.1	PG4200800	58 x 7.0
82.5	67.0	6.3	PG4400825	66.04 x 5.33
85.0	69.5	6.3	PG4400850	69.22 x 5.33
85.0	64.0	8.1	PG4200850	63 x 7.0
90.0	79.0	4.2	PG4600900	78.97 x 3.53
90.0	74.5	6.3	PG4400900	72.39 x 5.33
90.0	69.0	8.1	PG4200900	68 x 7.0
95.0	84.0	4.2	PG4600950	82.14 x 3.53
95.0	79.5	6.3	PG4400950	78.74 x 5.33
95.0	74.0	8.1	PG4200950	73 x 7.0
100.0	89.0	4.2	PG4601000	88.49 x 3.53
100.0	84.5	6.3	PG4401000	81.92 x 5.33
100.0	79.0	8.1	PG4201000	78 x 7.0
101.6	86.1	6.3	PG4401016	85.09 x 5.33
105.0	94.0	4.2	PG4601050	91.67 x 3.53
105.0	89.5	6.3	PG4401050	88.27 x 5.33
108.0	92.5	6.3	PG4401080	91.44 x 5.33
110.0	99.0	4.2	PG4601100	98.02 x 3.53
110.0	94.5	6.3	PG4401100	91.44 x 5.33
110.0	89.0	8.1	PG4201100	88 x 7.0
115.0	99.5	6.3	PG4401150	97.79 x 5.33
120.0	109.0	4.2	PG4601200	107.54 x 3.53
120.0	104.5	6.3	PG4401200	100.97 x 5.33
120.0	99.0	8.1	PG4201200	98 x 7.0
125.0	114.0	4.2	PG4601250	113.89 x 3.53
125.0	109.5	6.3	PG4401250	107.32 x 5.33
125.0	104.0	8.1	PG4201250	103 x 7.0



Turcon® Glyd Ring®

Bore Dia.	Groove Dia.	Groove Width	Part No.	O-Ring Dimensions
D _N H9	d ₁ h9	L ₁ +0.2		
127.0	111.5	6.3	PG4401270	110.49 x 5.33
130.0	114.5	6.3	PG4401300	113.67 x 5.33
130.0	109.0	8.1	PG4201300	108 x 7.0
132.0	121.0	4.2	PG4601320	120.24 x 3.53
135.0	114.0	8.1	PG4401350	113.67 x 7.0
140.0	124.5	6.3	PG4601400	123.19 x 5.33
140.0	119.0	8.1	PG4401400	116.84 x 7.0
145.0	129.5	6.3	PG4601450	126.37 x 5.33
145.0	124.0	8.1	PG4401450	123.19 x 7.0
150.0	134.5	6.3	PG4601500	132.72 x 5.33
150.0	129.0	8.1	PG4401500	126.37 x 7.0
155.0	134.0	8.1	PG4401550	132.72 x 7.0
160.0	144.5	6.3	PG4601600	142.24 x 5.33
160.0	139.0	8.1	PG4401600	135.89 x 7.0
165.0	144.0	8.1	PG4401650	142.24 x 7.0
170.0	149.0	8.1	PG4401700	145.42 x 7.0
175.0	154.0	8.1	PG4401750	151.77 x 7.0
180.0	164.5	6.3	PG4601800	164.47 x 5.33
180.0	159.0	8.1	PG4401800	158.12 x 7.0
190.0	169.0	8.1	PG4401900	164.47 x 7.0
194.0	178.5	6.3	PG4601940	177.17 x 5.33
200.0	184.5	6.3	PG4602000	183.52 x 5.33
200.0	179.0	8.1	PG4402000	177.17 x 7.0
205.0	184.0	8.1	PG4402050	183.52 x 7.0
210.0	189.0	8.1	PG4402100	183.52 x 7.0
215.0	194.0	8.1	PG4402150	189.87 x 7.0
220.0	199.0	8.1	PG4402200	196.22 x 7.0
230.0	214.5	6.3	PG4602300	208.92 x 5.33
230.0	209.0	8.1	PG4402300	208.92 x 7.0
240.0	219.0	8.1	PG4402400	215.27 x 7.0
250.0	134.5	6.3	PG4602500	234.32 x 5.33
250.0	229.0	8.1	PG4402500	227.97 x 7.0
250.0	225.5	8.1	PG4202500	215.27 x 7.0
254.0	233.0	8.1	PG4402540	227.97 x 7.0
260.0	239.0	8.1	PG4402600	240.67 x 7.0
265.0	244.0	8.1	PG4402650	240.67 x 7.0
268.0	247.0	8.1	PG4402680	240.67 x 7.0
270.0	249.0	8.1	PG4402700	240.67 x 7.0
280.0	259.0	8.1	PG4402800	253.37 x 7.0
290.0	269.0	8.1	PG4402900	266.07 x 7.0
300.0	279.0	8.1	PG4403000	278.77 x 7.0
300.0	275.5	8.1	PG4203000	266.07 x 7.0

Bore Dia.	Groove Dia.	Groove Width	Part No.	O-Ring Dimensions
D _N H9	d ₁ h9	L ₁ +0.2		
304.8	283.8	8.1	PG4403048	278.77 x 7.0
310.0	289.0	8.1	PG4403100	278.77 x 7.0
320.0	299.0	8.1	PG4403200	291.47 x 7.0
320.0	295.5	8.1	PG4203200	291.47 x 7.0
330.0	305.5	8.1	PG4403300	304.17 x 7.0
340.0	315.5	8.1	PG4403400	316.87 x 7.0
350.0	325.5	8.1	PG4403500	316.87 x 7.0
360.0	335.5	8.1	PG4403600	329.57 x 7.0
370.0	345.5	8.1	PG4403700	342.27 x 7.0
380.0	355.5	8.1	PG4403800	354.97 x 7.0
400.0	375.5	8.1	PG4404000	367.67 x 7.0
420.0	395.5	8.1	PG4404200	393.07 x 7.0
430.0	405.5	8.1	PG4404300	405.26 x 7.0
440.0	415.5	8.1	PG4404400	405.26 x 7.0
450.0	425.5	8.1	PG4404500	417.96 x 7.0
460.0	435.5	8.1	PG4404600	430.66 x 7.0
480.0	455.5	8.1	PG4404800	456.06 x 7.0
500.0	475.5	8.1	PG4405000	468.76 x 7.0
555.0	530.5	8.1	PG4405550	506.86 x 7.0
600.0	575.5	8.1	PG4406000	557.66 x 7.0
640.0	615.5	8.1	PG4406400	608.08 x 7.0
660.0	635.5	8.1	PG4406600	633.48 x 7.0
700.0	672.0	9.5	PG4407000	670 x 8.4
710.0	682.0	9.5	PG4407100	680 x 8.4
740.0	712.0	9.5	PG4407400	710 x 8.4
780.0	752.0	9.5	PG4407800	750 x 8.4
800.0	772.0	9.5	PG4408000	770 x 8.4
900.0	872.0	9.5	PG4409000	870 x 8.4
1000.0	972.0	9.5	PG46X1000	970 x 8.4
1000.0	962.0	13.8	PG44X1000	960 x 12.0
1050.0	1022.0	9.5	PG46X1050	1020 x 8.4
1065.0	1027.0	13.8	PG44X1065	1025 x 12.0
1070.0	1032.0	13.8	PG44X1070	1030 x 12.0
1200.0	1172.0	9.5	PG46X1200	1170 x 8.4
1200.0	1162.0	13.8	PG44X1200	1160 x 12.0
1225.0	1187.0	13.8	PG44X1225	1185 x 12.0
1500.0	1462.0	13.8	PG44X1500	1460 x 12.0
2000.0	1962.0	13.8	PG44X2000	1960 x 12.0
2700.0	2662.0	13.8	PG44X2700	2660 x 12.0

All dimensions in bold type are suitable for installation in grooves to ISO 7425/1, bore dia. in accordance with ISO 3320. Other dimensions and all intermediate sizes up to 2700 mm dia. including inch sizes can be supplied. All O-Rings with 12 mm cross section are delivered as special Profiling.

TURCON[®] GLYD RING[®] T

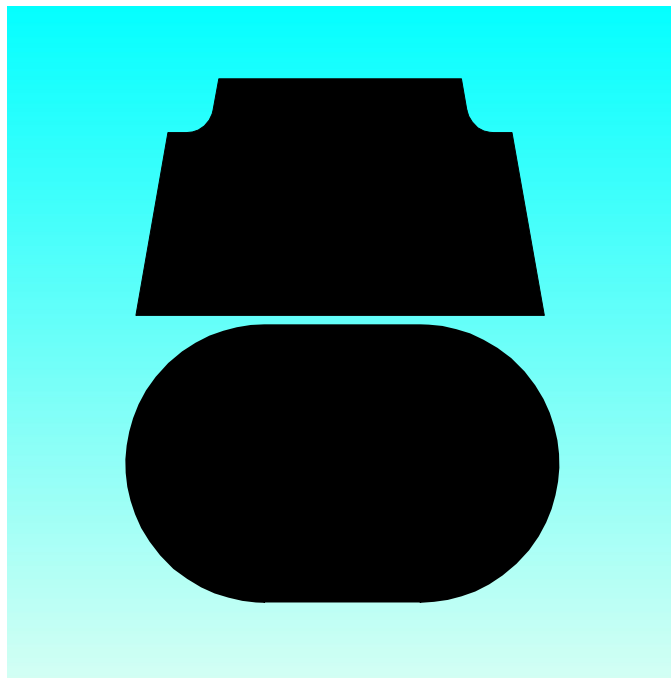

- Double Acting -

- Rubber Energised Plastic Faced Seal -

- Material -

- Turcon[®], Zurcon[®] and Elastomer -





■ Turcon® Glyd Ring® T *

Description

Turcon® Glyd Ring® T is a further technical development of the Turcon® Glyd Ring® seal which has been successfully used for decades. It is fully interchangeable with the earlier Glyd Ring® seals in all new applications. Glyd Ring® T meets all the market demands for a function-specific seal solution, observing economic and ecological aspects.

The benefits of the patented seal concept are provided by the innovative functional principle of the trapezoidal profile cross-section.

Both lateral profile flanks are inclined so that the seal profile tapers towards the seal surface. The profile can thus retain the robust and compact form typical of piston seals without losing any of the flexibility required to achieve a pressure-related maximum compression (Figure 14).

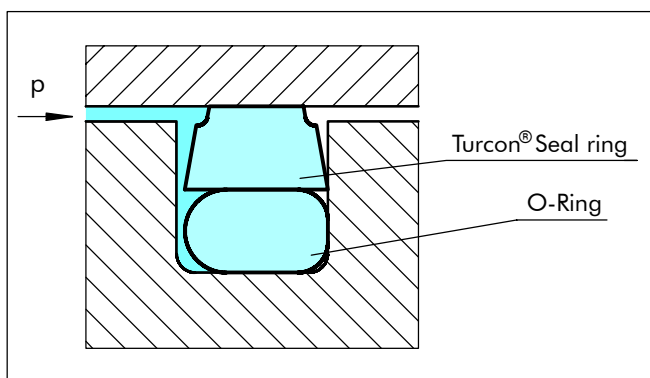

Figure 14 Turcon® Glyd Ring® T

The edge angle created by the special Glyd Ring® T cross-sectional form permits an additional degree of freedom and enables a slight tilting movement of the seal. The maximum compression is thus always shifted towards the area of the seal edge directly exposed to the pressure. On the low-pressure edge of the seal, on the other hand, the Glyd Ring® T exhibits only zones with neutral strains without compressive or shearing loads, thus effectively reducing the danger of gap extrusion. The resulting benefits for the user can be seen in the following list.

* Patent-No.:

DE 41 40833 C3

EP 0 582 593

Japan 2 799 367

USA 5,433,452

Advantages

The benefits offered to date by the Glyd Ring® are still retained in full, and are now complemented by a number of further important advantages:

- Very good static leak-tightness
- Increased clearance possible (approx. +50%), depending on the operating conditions
- Due to the larger extrusion gap, safe use even with soiled media
- Low friction, no stick-slip effect
- Simple groove design, one-piece pistons possible
- Installation grooves to ISO 7425/1
- Adaptable to the operating conditions due to a wide range of possible materials (Turcon®, Zurcon®)
- Suitable for new environmentally safe hydraulic fluids
- Available for all cylinder diameters up to 2.700 mm.

Application Examples

The Turcon® Glyd Ring® T is the recommended sealing element for double acting pistons of hydraulic components such as:

- Injection moulding machines
- Machine tools
- Presses
- Excavators
- Forklifts & handling machinery
- Agriculture
- Valves for hydraulic & pneumatic circuits.

It is particularly recommended for heavy duty and large diameter applications.



Turcon[®] Glyd Ring[®] T

Technical Data

Operating conditions

pressure: Up to 80 MPa

Speed: Up to 15 m/s

Temperature: -45°C to +200°C *)
(depending on O-Ring material).

Media: Mineral oil-based hydraulic fluids, barely flammable hydraulic fluids, environmentally safe hydraulic fluids (bio-oils), water, air and others, depending on the O-Ring material

Clearance: The maximum permissible radial clearance s_{max} is shown in Table XII, as a function of the operating pressure and functional diameter.

Important Note:

The above data are maximum values and cannot be used at the same time. e.g. the maximum operating speed depends on material type, pressure, temperature and gap value. Temperature range also dependent on medium.

*) In the case of unpressurized applications in temperatures below 0°C please contact our application engineers for assistance !

Materials

Standard Application:

- For hydraulic components with reciprocating movement in mineral oils containing zinc or medium with good lubricating performance.

Turcon[®] Seal: Turcon[®] T46

Energiser: O-Ring NBR 70 shore A or FKM 70 Shore A depending on the temperature

Set reference: T46N or T46V

Special Application:

- Non-lubricating fluids or pneumatic applications require self-lubricating sealing materials. Therefore we recommend:

Turcon[®] Seal: Turcon[®] T40

Energiser: O-Ring NBR 70 Shore A or FKM 70 Shore A depending on the temperature

Set reference: T40N or T40V

- If rougher surface finish must be sealed, we recommend:

Zurcon[®] Seal: Zurcon[®] Z51

Energiser: O-Ring NBR 70 Shore A

Set reference: Z51N

Table XI Turcon[®] and Zurcon[®] Materials for Glyd Ring[®] T

Material, Applications, Properties	Code	O-Ring Material	Code	O-Ring Operating Temp.* °C	Mating Surface Material	MPa max.
Turcon[®] T46 Standard material for hydraulics, high compressive strength, good sliding and wear properties, good extrusion resistance, BAM tested. Bronze filled Colour: Greyish to dark brown	T46	NBR - 70 Shore A	N	-30 to +100	Steel tubes Steel, hardened Cast iron	60
		NBR - Low temp. 70 Shore A	T	-45 to +80		
		FKM - 70 Shore A	V	-10 to +200		
Turcon[®] T40 For all lubricating and non-lubricating hydraulic fluids, hydraulic oils without zinc, water hydraulic, soft mating surfaces, good extrusion resistance. High carbon fibre filled Colour: Grey	T40	NBR - 70 Shore A	N	-30 to +100	Steel Cast iron Stainless steel Aluminium Bronze	25
		NBR - Low temp. 70 Shore A	T	-45 to +80		
		FKM - 70 Shore A	V	-10 to +200		
		EPDM - 70 Shore A	E**	-45 to +145		
Zurcon[®] Z51*** For lubricating hydraulic fluids, high abrasion resistance, high extrusion resistance , limited chemical resistance. Cast polyurethane Colour: Yellow to light-brown	Z51	NBR - 70 Shore A	N	-30 to +100	Steel Steel, hardened Cast iron Ceramic coating Stainless steel	80
		NBR - Low temp. 70 Shore A	T	-45 to +80		

* The O-Ring Operation Temperature is only valid in mineral hydraulic oil. BAM: Tested by "Bundes Anstalt Materialprüfung, Germany".

Highlighted materials are standard. **Material not suitable for mineral oils. *** max. Ø 2300 mm



Installation Recommendation

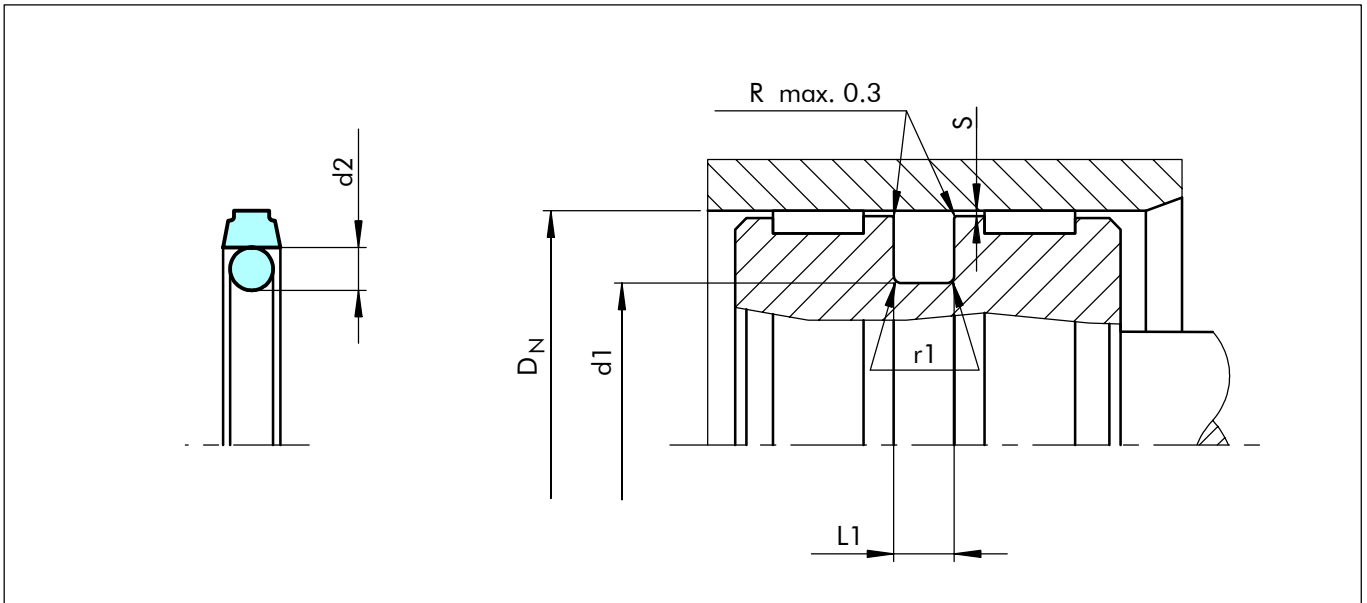

Figure 15 Installation drawing

Table XII Installation Dimensions

Series No.	Bore Diameter D_N H9			Groove Diameter d_1 h9	Groove Width $L_1 +0.2$	Radius r_1	Radial Clearance S max*			O-Ring Cross-Sec. d_2
	Standard Application	Light Application	Heavy Duty Application				10 MPa	20 MPa	40 MPa	
PT00	8 - 14.9	15 - 39.9	--	$D_N-4.9$	2.2	0.4	0.40	0.30	0.20	1.78
PT01	15 - 39.9	40 - 79.9	--	$D_N-7.5$	3.2	0.6	0.60	0.50	0.30	2.62
PT02	40 - 79.9	80 - 132.9	15 - 39.9	$D_N-11.0$	4.2	1.0	0.70	0.50	0.30	3.53
PT03	80 - 132.9	133 - 329.9	40 - 79.9	$D_N-15.5$	6.3	1.3	0.80	0.60	0.40	5.33
PT04	133 - 329.9	330 - 669.9	80 - 132.9	$D_N-21.0$	8.1	1.8	0.80	0.60	0.40	7.00
PT08	330 - 669.9	670 - 999.9	133 - 329.9	$D_N-24.5$	8.1	1.8	0.90	0.70	0.50	7.00
PT05	670 - 999.9	--	330 - 669.9	$D_N-28.0$	9.5	2.5	1.00	0.80	0.60	8.40
PT06**	≥ 1000			$D_N-38.0$	13.8	3.0	1.20	0.90	0.70	12.00

* At pressures > 40 MPa use diameter tolerance H8/f8 (bore/piston) in area of the seal.

** PT06 energiser has a special shape.

Ordering example

Turcon® Glyd Ring® T, complete with O-Ring, standard application, series PT03 (from Table XII).

Bore diameter: $D_N = 80.0$ mm

Part No.: PT0300800 (from Table XIII)

Select the material from Table XI. The corresponding code numbers are appended to the Part No. (from Table XIII). Together they form the Order No.

For all intermediate sizes not shown in Table XIII, the Order No. can be determined from the example opposite.

*** For diameters ≥ 1000.0 mm multiply only by factor 1.

Example: PT06 for diameter 1200.0 mm.

Order no.: PT06X1200 - T46N.

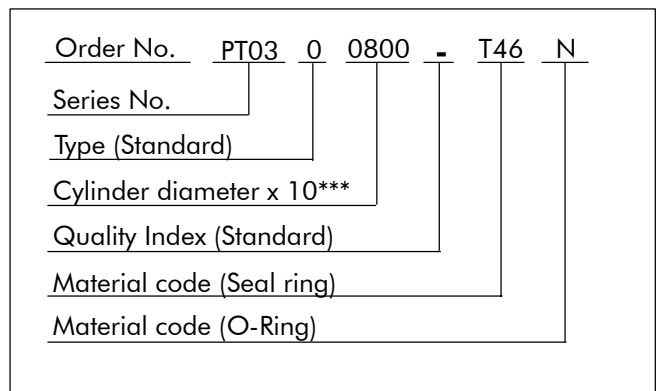



Table XIII Installation dimensions/Part No.

Bore Dia.	Groove Dia.	Groove Width	Part No.	O-Ring Dimensions
D _N H9	d ₁ h9	L ₁ +0.2		
8.0	3.1	2.2	PT0000080	2.90 x 1.78
10.0	5.1	2.2	PT0000100	4.80 x 1.8
12.0	7.1	2.2	PT0000120	6.70 x 1.8
14.0	9.1	2.2	PT0000140	8.75 x 1.8
15.0	7.5	3.2	PT0100150	7.59 x 2.62
16.0	11.1	2.2	PT0000160	10.82 x 1.78
16.0	8.5	3.2	PT0100160	7.59 x 2.62
18.0	13.1	2.2	PT0000180	12.42 x 1.78
18.0	10.5	3.2	PT0100180	9.19 x 2.62
19.05	11.55	3.2	PT0100190	10.77 x 2.62
20.0	15.1	2.2	PT0000200	14.00 x 1.78
20.0	12.5	3.2	PT0100200	12.37 x 2.62
21.0	13.5	3.2	PT0100210	12.37 x 2.62
22.0	17.1	2.2	PT0000220	17.17 x 1.78
22.0	14.5	3.2	PT0100220	13.94 x 2.62
24.0	16.5	3.2	PT0100240	15.54 x 2.62
25.0	20.1	2.2	PT0000250	18.77 x 1.78
25.0	17.5	3.2	PT0100250	17.12 x 2.62
25.0	14.0	4.2	PT0200250	13.87 x 3.53
25.4	20.5	2.2	PT0000254	17.12 x 2.62
28.0	20.5	3.2	PT0100280	20.29 x 2.62
30.0	22.5	3.2	PT0100300	21.89 x 2.62
32.0	27.1	2.2	PT0000320	26.70 x 1.78
32.0	24.5	3.2	PT0100320	23.47 x 2.62
32.0	21.0	4.2	PT0200320	20.22 x 3.53
35.0	27.5	3.2	PT0100350	26.64 x 2.62
35.0	24.0	4.2	PT0200350	23.40 x 3.53
36.0	28.5	3.2	PT0100360	28.24 x 2.62
38.0	30.5	3.2	PT0100380	29.82 x 2.62
40.0	32.5	3.2	PT0100400	31.42 x 2.62
40.0	29.0	4.2	PT0200400	28.17 x 3.53
42.0	31.0	4.2	PT0200420	29.75 x 3.53
44.45	36.95	3.2	PT0100444	36.17 x 2.62
45.0	34.0	4.2	PT0200450	32.92 x 3.53
48.0	37.0	4.2	PT0200480	36.09 x 3.53
50.0	42.5	3.2	PT0100500	40.94 x 2.62
50.0	39.0	4.2	PT0200500	37.70 x 3.53
50.0	34.5	6.3	PT0300500	32.69 x 5.33
50.8	43.3	3.2	PT0100508	42.52 x 2.62
50.8	39.8	4.2	PT0200508	37.70 x 3.53
52.0	41.0	4.2	PT0200520	40.87 x 3.53
53.0	42.0	4.2	PT0200530	40.87 x 3.53

Bore Dia.	Groove Dia.	Groove Width	Part No.	O-Ring Dimensions
D _N H9	d ₁ h9	L ₁ +0.2		
55.0	44.0	4.2	PT0200550	44.04 x 3.53
57.0	46.0	4.2	PT0200570	44.04 x 3.53
58.0	47.0	4.2	PT0200580	47.22 x 3.53
60.0	49.0	4.2	PT0200600	47.22 x 3.53
62.0	51.0	4.2	PT0200620	50.39 x 3.53
63.0	52.0	4.2	PT0200630	50.39 x 3.53
63.0	47.5	6.3	PT0300630	46.99 x 5.33
65.0	54.0	4.2	PT0200650	53.57 x 3.53
68.0	57.0	4.2	PT0200680	56.74 x 3.53
70.0	59.0	4.2	PT0200700	56.74 x 3.53
70.0	54.5	6.3	PT0300700	53.34 x 5.33
75.0	64.0	4.2	PT0200750	63.09 x 3.53
75.0	59.5	6.3	PT0300750	56.52 x 3.53
80.0	69.0	4.2	PT0200800	66.27 x 3.53
80.0	64.5	6.3	PT0300800	62.87 x 5.33
80.0	59.0	8.1	PT0400800	58 x 7.0
82.5	67.0	6.3	PT0300825	66.04 x 5.33
85.0	69.5	6.3	PT0300850	69.22 x 5.33
85.0	64.0	8.1	PT0400850	63 x 7.0
90.0	79.0	4.2	PT0200900	78.97 x 3.53
90.0	74.5	6.3	PT0300900	72.39 x 5.33
90.0	69.0	8.1	PT0400900	68 x 7.0
95.0	84.0	4.2	PT0200950	82.14 x 3.53
95.0	79.5	6.3	PT0300950	78.74 x 5.33
95.0	74.0	8.1	PT0400950	73 x 7.0
100.0	89.0	4.2	PT0201000	88.49 x 3.53
100.0	84.5	6.3	PT0301000	81.92 x 5.33
100.0	79.0	8.1	PT0401000	78 x 7.0
101.6	86.1	6.3	PT0301016	85.09 x 5.33
105.0	94.0	4.2	PT0201050	91.67 x 3.53
105.0	89.5	6.3	PT0301050	88.27 x 5.33
108.0	92.5	6.3	PT0301080	91.44 x 5.33
110.0	99.0	4.2	PT0201100	98.02 x 3.53
110.0	94.5	6.3	PT0301100	91.44 x 5.33
110.0	89.0	8.1	PT0401100	88 x 7.0
115.0	99.5	6.3	PT0301150	97.79 x 5.33
120.0	109.0	4.2	PT0201200	107.54 x 3.53
120.0	104.5	6.3	PT0301200	100.97 x 5.33
120.0	99.0	8.1	PT0401200	98 x 7.0
125.0	114.0	4.2	PT0201250	113.89 x 3.53
125.0	109.5	6.3	PT0301250	107.32 x 5.33
125.0	104.0	8.1	PT0401250	103 x 7.0



Bore Dia.	Groove Dia.	Groove Width	Part No.	O-Ring Dimensions
D _N H9	d ₁ h9	L ₁ +0.2		
127.0	111.5	6.3	PT0301270	110.49 x 5.33
130.0	114.5	6.3	PT0301300	113.67 x 5.33
130.0	109.0	8.1	PT0401300	108 x 7.0
132.0	121.0	4.2	PT0201320	120.24 x 3.53
135.0	114.0	8.1	PT0401350	113.67 x 7.0
140.0	124.5	6.3	PT0301400	123.19 x 5.33
140.0	119.0	8.1	PT0401400	116.84 x 7.0
145.0	129.5	6.3	PT0301450	126.37 x 5.33
145.0	124.0	8.1	PT0401450	123.19 x 7.0
150.0	134.5	6.3	PT0301500	132.72 x 5.33
150.0	129.0	8.1	PT0401500	126.37 x 7.0
155.0	134.0	8.1	PT0401550	132.72 x 7.0
160.0	144.5	6.3	PT0301600	142.24 x 5.33
160.0	139.0	8.1	PT0401600	135.89 x 7.0
165.0	144.0	8.1	PT0401650	142.24 x 7.0
170.0	149.0	8.1	PT0401700	145.42 x 7.0
175.0	154.0	8.1	PT0401750	151.77 x 7.0
180.0	164.5	6.3	PT0301800	164.47 x 5.33
180.0	159.0	8.1	PT0401800	158.12 x 7.0
190.0	169.0	8.1	PT0401900	164.47 x 7.0
194.0	178.5	6.3	PT0301940	177.17 x 5.33
200.0	184.5	6.3	PT0302000	183.52 x 5.33
200.0	179.0	8.1	PT0402000	177.17 x 7.0
205.0	184.0	8.1	PT0402050	183.52 x 7.0
210.0	189.0	8.1	PT0402100	183.52 x 7.0
215.0	194.0	8.1	PT0402150	189.87 x 7.0
220.0	199.0	8.1	PT0402200	196.22 x 7.0
230.0	214.5	6.3	PT0302300	208.92 x 5.33
230.0	209.0	8.1	PT0402300	208.92 x 7.0
240.0	219.0	8.1	PT0402400	215.27 x 7.0
250.0	134.5	6.3	PT0302500	234.32 x 5.33
250.0	229.0	8.1	PT0402500	227.97 x 7.0
250.0	225.5	8.1	PT0802500	215.27 x 7.0
254.0	233.0	8.1	PT0402540	227.97 x 7.0
260.0	239.0	8.1	PT0402600	240.67 x 7.0
265.0	244.0	8.1	PT0402650	240.67 x 7.0
268.0	247.0	8.1	PT0402680	240.67 x 7.0
270.0	249.0	8.1	PT0402700	240.67 x 7.0
280.0	259.0	8.1	PT0402800	253.37 x 7.0
290.0	269.0	8.1	PT0402900	266.07 x 7.0
300.0	279.0	8.1	PT0403000	278.77 x 7.0
300.0	275.5	8.1	PT0803000	266.07 x 7.0

Bore Dia.	Groove Dia.	Groove Width	Part No.	O-Ring Dimensions
D _N H9	d ₁ h9	L ₁ +0.2		
304.8	283.8	8.1	PT0403048	278.77 x 7.0
310.0	289.0	8.1	PT0403100	278.77 x 7.0
320.0	299.0	8.1	PT0403200	291.47 x 7.0
320.0	295.5	8.1	PT0803200	291.47 x 7.0
330.0	305.5	8.1	PT0803300	304.17 x 7.0
340.0	315.5	8.1	PT0803400	316.87 x 7.0
350.0	325.5	8.1	PT0803500	316.87 x 7.0
360.0	335.5	8.1	PT0803600	329.57 x 7.0
370.0	345.5	8.1	PT0803700	342.27 x 7.0
380.0	355.5	8.1	PT0803800	354.97 x 7.0
400.0	375.5	8.1	PT0804000	367.67 x 7.0
420.0	395.5	8.1	PT0804200	393.07 x 7.0
430.0	405.5	8.1	PT0804300	405.26 x 7.0
440.0	415.5	8.1	PT0804400	405.26 x 7.0
450.0	425.5	8.1	PT0804500	417.96 x 7.0
460.0	435.5	8.1	PT0804600	430.66 x 7.0
480.0	455.5	8.1	PT0804800	456.06 x 7.0
500.0	475.5	8.1	PT0805000	468.76 x 7.0
555.0	530.5	8.1	PT0805550	506.86 x 7.0
600.0	575.5	8.1	PT0806000	557.66 x 7.0
640.0	615.5	8.1	PT0806400	608.08 x 7.0
660.0	635.5	8.1	PT0806600	633.48 x 7.0
700.0	672.0	9.5	PT0507000	670 x 8.4
710.0	682.0	9.5	PT0507100	680 x 8.4
740.0	712.0	9.5	PT0507400	710 x 8.4
780.0	752.0	9.5	PT0507800	750 x 8.4
800.0	772.0	9.5	PT0508000	770 x 8.4
900.0	872.0	9.5	PT0509000	870 x 8.4
1000.0	972.0	9.5	PT05X1000	970 x 8.4
1000.0	962.0	13.8	PT06X1000	960 x 12.0
1050.0	1022.0	9.5	PT05X1050	1020 x 8.4
1065.0	1027.0	13.8	PT06X1065	1025 x 12.0
1070.0	1032.0	13.8	PT06X1070	1030 x 12.0
1200.0	1172.0	9.5	PT05X1200	1170 x 8.4
1200.0	1162.0	13.8	PT06X1200	1160 x 12.0
1225.0	1187.0	13.8	PT06X1225	1185 x 12.0
1500.0	1462.0	13.8	PT06X1500	1460 x 12.0
2000.0	1962.0	13.8	PT06X2000	1960 x 12.0
2700.0	2662.0	13.8	PT06X2700	2660 x 12.0

All dimensions in bold type are suitable for installation in grooves to ISO 7425/1, bore dia. in accordance with ISO 3320. Other dimensions and all intermediate sizes up to 2700 mm dia. including inch sizes can be supplied. All O-Rings with 12 mm cross section are delivered as special profiling.



Turcon[®] Glyd Ring[®] T

TURCON[®] AQ-SEAL[®] 5

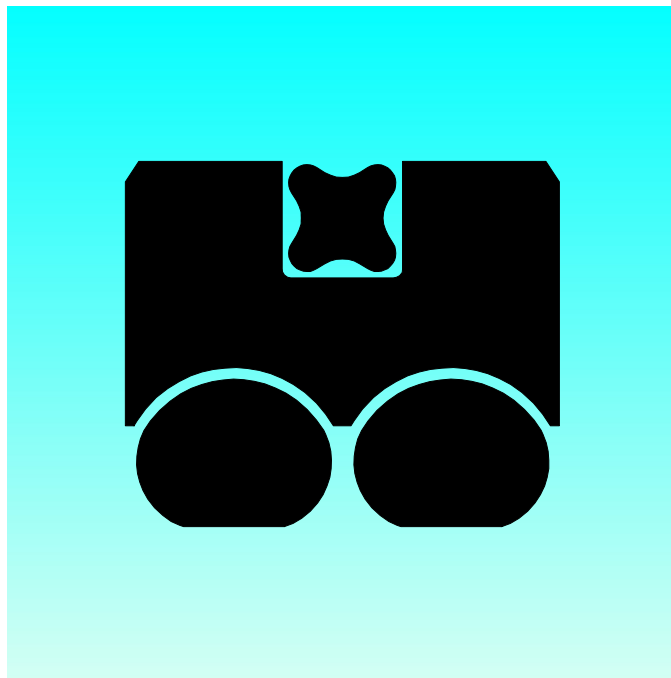

- Double Acting -
- Rubber Energised Plastic Faced Seal -

- Material -
- Turcon[®] and Elastomer -





■ Turcon® AQ-Seal® 5*

Description

The Turcon® AQ-Seal® 5 is a patented development of the proven standard Turcon® AQ-Seal®.

The seal profile of the Turcon® ring has been redesigned on both the dynamic and static sealing surface. Two O-Rings are used to energize the seal instead of one.

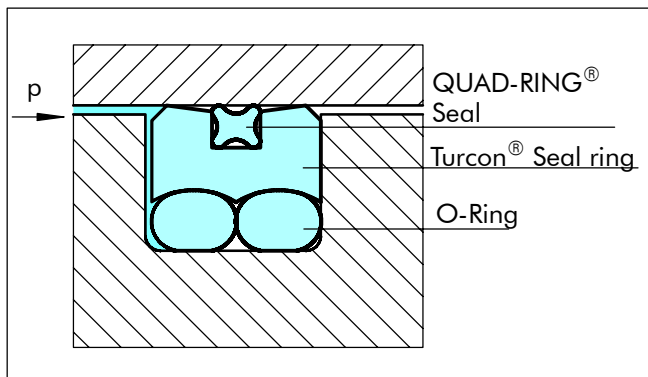

Figure 16 Turcon® AQ-Seal® 5

The AQ-Seal® 5 combines the benefits of a low-friction Turcon® slipper seal with the high sealing characteristics of an elastomeric seal by incorporating a limited foot print QUAD-RING® Seal in the dynamic sealing face. This optimizes leakage control while minimizing friction.

The particular characteristics of the AQ-Seal® 5 are the special seal profile with a defined seal edge and the use of two O-Rings as energizing elements to optimize the pressure profile and to reduce the force of attack at gas permeability.

* Patent-No. EP 0 424 372

Advantages

- High sealing effect in applications requiring media separation, e.g. fluid/fluid or fluid/gas
- Double security through the combination of low-friction special materials with elastomer seals
- Low gas permeation rate
- Higher pressure application, higher sliding speed compared to the AQ-Seal®
- Outstanding sliding properties, no stick-slip effect.

Application Examples

The Turcon® AQ-Seal® 5 is the recommended sealing element for double acting pistons of accumulators and positioning and holding cylinders for:

- Machine tools
- Presses
- Rolling mills
- Off shore
- Accumulators
- Heavy duty suspension cylinders

It is particularly recommended for heavy duty and large diameter applications.

Technical Data

Operating conditions

pressure: 60 MPa

Speed: Up to 3 m/s

Temperature: -30°C to +200°C *)
(depending on O-Ring and QUAD-RING® Seal material)
(For applications at low temperatures below -30°C, please contact us).

Media: For all common hydraulic fluids, including bio-oils and gases

Clearance: The maximum permissible radial clearance S_{max} is shown in Table XV, as a function of the operating pressure and functional diameter.

Important Note:

The above data are maximum values and cannot be used at the same time. e.g. the maximum operating speed depends on material type, pressure, temperature and gap value.
Temperature range also dependent on medium.

*) In the case of unpressurized applications in temperatures below 0°C please contact our application engineers for assistance !



Materials

Standard Application:

- For hydraulic components in mineral oils or medium with good lubricating performance.
- Mineral oils and gases

Turcon[®] Seal: Turcon[®] T46

Energiser: O-Ring and QUAD-RING Seal in NBR
70 Shore A (code N)

Special Application:

- For special applications requiring other material combinations, please contact your local Busak+Shamban Company.

Table XIV Turcon[®] Materials for Turcon[®] AQ-Seal[®] 5

Material, Applications, Properties	Code	O-Ring Material	Code	O-Ring Operating Temp.* °C	Mating Surface Material	MPa max.
Turcon[®] T46 Standard material for hydraulics, high compressive strength, good sliding and wear properties, good extrusion resistance, BAM tested. Bronze filled Colour: Greyish to dark brown	T46	NBR - 70 Shore A	N	-30 to +100	Steel tubes Steel, hardened Cast iron	60
		FKM - 70 Shore A	V	-10 to +200		
Turcon[®] T40 For all lubricating and non-lubricating hydraulic fluids, hydraulic oils without zinc, water hydraulic, soft mating surfaces. Carbon fibre filled Colour: Grey	T40	NBR - 70 Shore A	N	-30 to +100	Steel Cast iron Stainless steel, Aluminium Bronze Alloys	25
		FKM - 70 Shore A	V	-10 to +200		
		EPDM-70 Shore A	E**	-45 to +145		
Turcon[®] T10 For oil hydraulic and pneumatic for all lubricating and non-lubricating fluids, high extrusion resistance, good chemical resistance, BAM tested. Carbon, graphite filled Colour: Black	T10	NBR - 70 Shore A	N	-30 to +100	Steel Stainless steel	60
		FKM - 70 Shore A	V	-20 to +200		
		EPDM-70 Shore A	E**	-45 to +145		

* The O-Ring Operation Temperature is only valid in mineral hydraulic oil. BAM: Tested by "Bundes Anstalt Materialprüfung, Germany".

Highlighted materials are standard. **Material not suitable for mineral oils.



Installation Recommendation

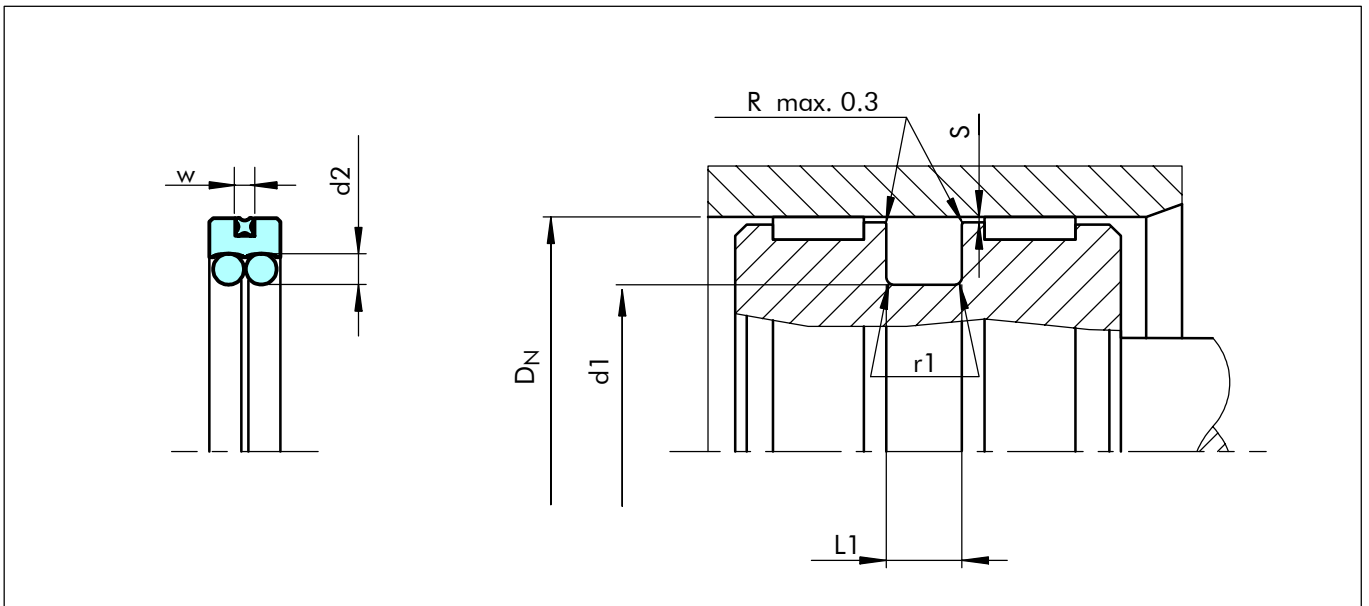

Figure 17 Installation drawing

Table XV Installation Dimensions

Series No.	Bore Diameter D_N H9		Groove Diameter d_1 h9	Groove Width $L_1 + 0.2$	Radius r_1	Radial Clearance S max*			O-Ring Cross Sec. d_2	QUAD-RING® Seal Cross Sec. W
	Recommended Range	Extended Range				10 MPa	20 MPa	30 MPa		
PQ01	40 - 79.9	25 - 140	$D_N - 10.0$	6.3	0.6	0.30	0.20	0.15	2.62	1.78
PQ02	80 - 132.9	50 - 250	$D_N - 13.0$	8.3	1.0	0.40	0.30	0.15	3.53	2.62
PQ03	133 - 462.9	100 - 480	$D_N - 18.0$	12.3	1.3	0.40	0.30	0.20	5.33	3.53
PQ04	463 - 700.0	425 - 700	$D_N - 31.0$	16.3	1.8	0.50	0.40	0.30	7.00	5.33

*At pressures > 30 MPa use diameter tolerance H8/f8 (bore/piston) in area of the seal.

Ordering example

Turcon® AQ-Seal® 5, complete with O-Ring and QUAD-RING® Seal, recommended range, Series PQ02 (from Table XV).

Bore diameter: $D_N = 80.0$ mm

Part No. PQ0200800 (from Table XVI)

Select the material from Table XIV. The corresponding code numbers are appended to the Part No. (from Table XVI). Together they form the Order No.

For all intermediate sizes not shown in Table XVI, the Order No. can be determined from the example opposite.

Order No.	PQ02	0	0800	-	T46	N
Series No.						
Type (Standard)						
Cylinder diameter x 10						
Quality Index (Standard)						
Material code (Seal ring)						
Material code (O-Ring)/(QUAD-RING® Seal)						



Table XVI Installation dimensions / Part No.

Bore Diameter	Groove Diameter	Groove Width	Part No.	O-Ring Dimensions	QUAD-RING® Dimensions
D _N H9	d ₁ h9	L ₁ +0.2			
40.0	30.0	6.3	PQ0100400	29.82 x 2.62	34.65 x 1.78
42.0	32.0	6.3	PQ0100420	31.42 x 2.62	37.82 x 1.78
45.0	35.0	6.3	PQ0100450	34.59 x 2.62	37.82 x 1.78
48.0	38.0	6.3	PQ0100480	37.77 x 2.62	41.00 x 1.78
50.0	40.0	6.3	PQ0100500	39.34 x 2.62	44.17 x 1.78
52.0	42.0	6.3	PQ0100520	40.94 x 2.62	47.35 x 1.78
55.0	45.0	6.3	PQ0100550	44.12 x 2.62	50.52 x 1.78
60.0	50.0	6.3	PQ0100600	48.90 x 2.62	53.70 x 1.78
63.0	53.0	6.3	PQ0100630	52.07 x 2.62	56.87 x 1.78
65.0	55.0	6.3	PQ0100650	53.64 x 2.62	60.05 x 1.78
70.0	60.0	6.3	PQ0100700	58.42 x 2.62	63.22 x 1.78
75.0	65.0	6.3	PQ0100750	63.17 x 2.62	69.57 x 1.78
80.0	67.0	8.3	PQ0200800	66.27 x 3.53	71.12 x 2.62
85.0	72.0	8.3	PQ0200850	69.44 x 3.53	75.87 x 2.62
90.0	77.0	8.3	PQ0200900	75.79 x 3.53	82.22 x 2.62
95.0	82.0	8.3	PQ0200950	78.97 x 3.53	82.22 x 2.62
100.0	87.0	8.3	PQ0201000	85.32 x 3.53	88.57 x 2.62
105.0	92.0	8.3	PQ0201050	91.67 x 3.53	94.92 x 2.62
110.0	97.0	8.3	PQ0201100	94.84 x 3.53	101.27 x 2.62
115.0	102.0	8.3	PQ0201150	101.19 x 3.53	107.62 x 2.62
120.0	107.0	8.3	PQ0201200	104.37 x 3.53	107.62 x 2.62
125.0	112.0	8.3	PQ0201250	110.72 x 3.53	113.97 x 2.62
130.0	117.0	8.3	PQ0201300	113.89 x 3.53	120.32 x 2.62
135.0	117.0	12.3	PQ0301350	113.67 x 5.33	123.42 x 3.53
140.0	122.0	12.3	PQ0301400	120.02 x 5.33	126.60 x 3.53
150.0	132.0	12.3	PQ0301500	129.54 x 5.33	136.12 x 3.53
160.0	142.0	12.3	PQ0301600	139.07 x 5.33	145.65 x 3.53
170.0	152.0	12.3	PQ0301700	148.49 x 5.33	158.35 x 3.53
180.0	162.0	12.3	PQ0301800	158.12 x 5.33	164.70 x 3.53
190.0	172.0	12.3	PQ0301900	170.82 x 5.33	177.40 x 3.53
200.0	182.0	12.3	PQ0302000	177.17 x 5.33	183.75 x 3.53
210.0	192.0	12.3	PQ0302100	189.87 x 5.33	196.45 x 3.53
220.0	202.0	12.3	PQ0302200	196.22 x 5.33	202.80 x 3.53
230.0	212.0	12.3	PQ0302300	208.92 x 5.33	215.50 x 3.53
240.0	222.0	12.3	PQ0302400	221.62 x 5.33	221.85 x 3.53
250.0	232.0	12.3	PQ0302500	227.97 x 5.33	234.55 x 3.53
280.0	262.0	12.3	PQ0302800	253.37 x 5.33	266.29 x 3.53
300.0	282.0	12.3	PQ0303000	278.77 x 5.33	278.99 x 3.53
320.0	302.0	12.3	PQ0303200	291.47 x 5.33	304.39 x 3.53

Bore diameters in bold type comply with the recommendations of ISO 3320.

All intermediate sizes up to 700 mm diameter can be supplied. Sizes > 700 mm diameter with special elastomers on request.



Bore Diameter	Groove Diameter	Groove Width	Part No.	O-Ring Dimensions	QUAD-RING® Dimensions
D_N H9	d_1 h9	L_1 +0.2			
350.0	332.0	12.3	PQ0303500	329.57 x 5.33	329.79 x 3.53
400.0	382.0	12.3	PQ0304000	380.37 x 5.33	380.59 x 3.53
420.0	402.0	12.3	PQ0304200	405.26 x 5.33	380.59 x 3.53
450.0	432.0	12.3	PQ0304500	430.66 x 5.33	430.66 x 3.53
480.0	449.0	16.3	PQ0404800	443.36 x 7.0	456.06 x 5.33
500.0	469.0	16.3	PQ0405000	468.76 x 7.0	456.06 x 5.33
600.0	569.0	16.3	PQ0406000	557.66 x 7.0	557.58 x 5.33
700.0	669.0	16.3	PQ0407000	658.88 x 7.0	658.88 x 5.33

Bore diameters in bold type comply with the recommendations of ISO 3320.

All intermediate sizes up to 700 mm diameter can be supplied.
 Sizes > 700 mm diameter with special elastomers on request.



TURCON[®] AQ-SEAL[®]

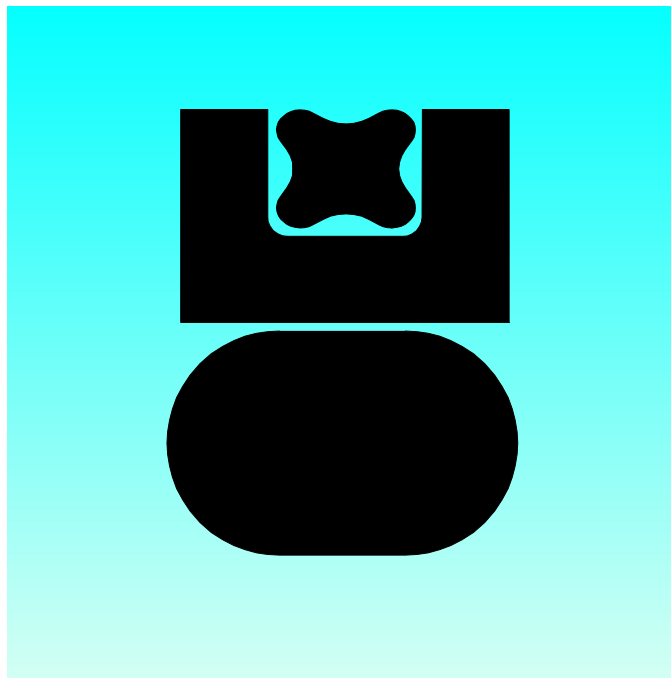

- Double Acting -
- Rubber Energised Plastic Faced Seal -

- Material -
- Turcon[®] and Elastomer -





■ Turcon® AQ-Seal®

Description

The Turcon® AQ-Seal® is a double-acting seal consisting of a seal ring of high-grade modified Turcon® material, a QUAD-RING® Seal and an O-Ring as energizing element.

The Turcon® seal ring and the QUAD-RING® Seal together assume the dynamic sealing function whilst the O-Ring performs the static sealing function.

Design

The AQ-Seal® is supplied as standard with radial notches on both sides. These ensure direct pressurizing of the seal under all operating conditions.

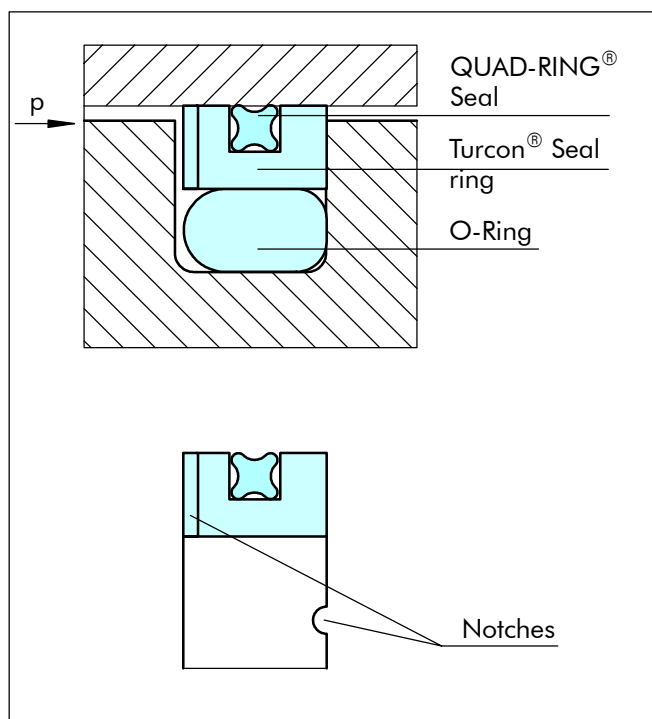

Figure 18 Turcon® AQ-Seal®

Advantages

- High sealing effect in applications requiring media separation, e.g. fluid/fluid or fluid/gas
- Double security through the combination of low-friction special materials with elastomer seals
- Simple groove design, small installation space, interchangeable with Turcon® Glyd Ring®, Turcon® Glyd Ring® T and Turcon® Stepseal® K installation according to ISO 7425/1
- Outstanding sliding properties, no stick-slip effect.

Application Examples

The Turcon® AQ-Seal® is the recommended sealing element for double acting pistons of accumulators and positioning and holding cylinders for:

- Machine tools
- Presses
- Accumulators
- Stabilisers
- Heavy duty suspension cylinders

Technical Data

Operating pressure:	40 MPa
Speed:	Up to 2 m/s
Temperature:	-45°C to +200°C *) (depending on O-Ring and QUAD-RING® Seal material) (For applications at low temperatures below -30°C, please contact us).
Media:	For all common hydraulic fluids, including bio-oils and gases
Clearance:	The maximum permissible radial clearance S_{max} is shown in Table XVIII, as a function of the operating pressure and functional diameter.

Important Note:

The above data are maximum values and cannot be used at the same time. e.g. the maximum operating speed depends on material type, pressure, temperature and gap value. Temperature range also dependent on medium.

*) In the case of unpressurized applications in temperatures below 0°C please contact our application engineers for assistance !



Materials

Standard Application:

- For hydraulic components in mineral oils or medium with good lubricating performance.
- Mineral oils and gases

Turcon® Seal: Turcon® T46

Energiser: O-Ring and QUAD-RING® Seal in NBR 70 Shore A (code N)

Special Application:

- For special applications requiring other material combinations, please contact your local Busak+Shamban Company.

Table XVII Turcon® Materials for Turcon® AQ-Seal®

Material, Applications, Properties	Code	O-Ring Material	Code	O-Ring Operating Temp.* °C	Mating Surface Material	MPa max.
Turcon® T46 Standard material for hydraulics, high compressive strength, good sliding and wear properties, good extrusion resistance, BAM tested. Bronze filled Colour: Greyish to dark brown	T46	NBR - 70 Shore A	N	-30 to +100	Steel tubes Steel, hardened Cast iron	40
		NBR - Low temp. 70 Shore A	T	-45 to +80		
		FKM - 70 Shore A	V	-10 to +200		
Turcon® T40 For all lubricating and non-lubricating hydraulic fluids, hydraulic oils without zinc, water hydraulic, soft mating surfaces. Carbon fibre filled Colour: Grey	T40	NBR - 70 Shore A	N	-30 to +100	Steel Cast iron Stainless steel, Aluminium Bronze Alloys	25
		NBR - Low temp. 70 Shore A	T	-45 to +80		
		FKM - 70 Shore A	V	-10 to +200		
		EPDM-70 Shore A	E**	-45 to +145		
Turcon® T10 For oil hydraulic and pneumatic for all lubricating and non-lubricating fluids, high extrusion resistance, good chemical resistance, BAM tested. Carbon, graphite filled Colour: Black	T10	NBR - 70 Shore A	N	-30 to +100	Steel Stainless steel	40
		NBR - Low temp. 70 Shore A	T	-45 to +80		
		FKM - 70 Shore A	V	-10 to +200		
		EPDM-70 Shore A	E**	-45 to +145		

* The O-Ring Operation Temperature is only valid in mineral hydraulic oil. BAM: Tested by "Bundes Anstalt Materialprüfung, Germany".

Highlighted materials are standard. **Material not suitable for mineral oils.



Installation Recommendation

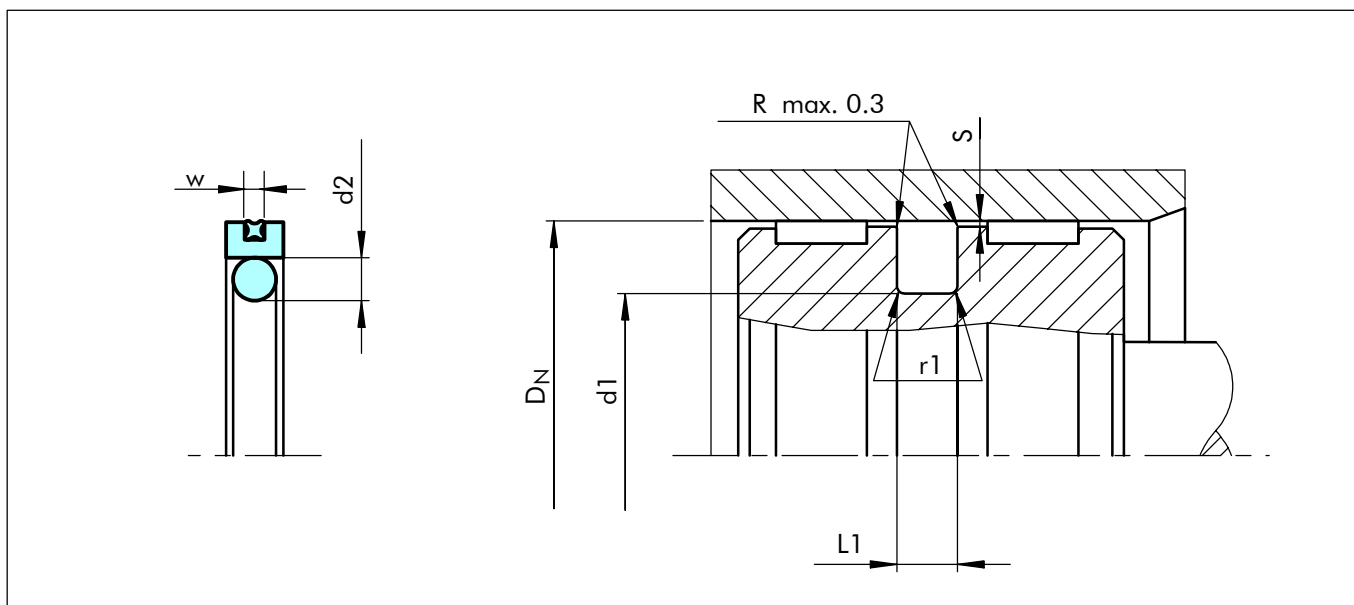

Figure 19 Installation drawing

Table XVIII Installation dimensions

Bore Diameter D_N H9				Groove Dia.	Groove Width	Radius	Radial Clearance S max			O-Ring Cross Section	QUAD-RING® Seal Cross Section
Standard Application		Light Application					10 MPa	20 MPa	40 MPa		
Series No.	Diameter Range	Series No.	Diameter Range	d_1 h9	$L_1 + 0.2$	r_1				d_2	W
PQ12	15 - 39.9	PQ14	40 - 79.9	$D_N - 11.0$	4.2	1.0	0.25	0.15	0.10	3.53	1.78
	40 - 79.9		80 - 132.9	$D_N - 15.5$	6.3	1.3	0.30	0.20	0.15	5.33	1.78
PQ22	80 - 132.9	PQ24	133 - 252.9	$D_N - 21.0$	8.1	1.8	0.30	0.20	0.15	7.00	2.62
	133 - 252.9		--	$D_N - 24.5$	8.1	1.8	0.30	0.20	0.15	7.00	2.62
PQ32	253 - 462.9	--	--	$D_N - 28.0$	9.5	2.5	0.45	0.30	0.25	8.40	3.53
PQ52	463 - 700.0	--	--	$D_N - 35.0$	11.5	3.0	0.55	0.40	0.35	10.00	5.33

Ordering example

Turcon® AQ-Seal®, complete with O-Ring and QUAD-RING® Seal, recommended range, Series PQ22 (from Table XVIII).

Bore diameter: $D_N = 80.0$ mm

Part No. PQ2200800 (from Table XIX)

Select the material from Table XVII. The corresponding code numbers are appended to the Part No. (from Table XIX). Together they form the Order No.

For all intermediate sizes not shown in Table XIX, the Order No. can be determined from the example opposite.

Order No.	PQ22	0	0800	-	T46	N
Series No.						
Type (Standard)						
Cylinder diameter x 10						
Quality Index (Standard)						
Material code (Seal ring)						
Material code (O-Ring)/(QUAD-RING® Seal)						



Table XIX Installation dimensions / Part No.

Bore Diameter	Groove Diameter	Groove Width	Part No.	O-Ring Dimensions	QUAD-RING® Dimensions
D _N H9	d ₁ h9	L ₁ +0.2			
16.0	5.0	4.2	PQ1200160	4.34 x 3.53	12.42 x 1.78
18.0	7.0	4.2	PQ1200180	6.42 x 3.53	14.00 x 1.78
20.0	9.0	4.2	PQ1200200	8.42 x 3.53	15.60 x 1.78
22.0	11.0	4.2	PQ1200220	10.69 x 3.53	17.17 x 1.78
25.0	14.0	4.2	PQ1200250	13.87 x 3.53	20.35 x 1.78
28.0	17.0	4.2	PQ1200280	15.47 x 3.53	23.52 x 1.78
30.0	19.0	4.2	PQ1200300	18.66 x 3.53	25.12 x 1.78
32.0	21.0	4.2	PQ1200320	20.22 x 3.53	26.70 x 1.78
35.0	24.0	4.2	PQ1200350	23.40 x 3.53	29.87 x 1.78
40.0	29.0	4.2	PQ1400400	28.17 x 3.53	34.65 x 1.78
42.0	31.0	4.2	PQ1400420	29.75 x 3.53	37.82 x 1.78
45.0	34.0	4.2	PQ1400450	32.92 x 3.53	37.82 x 1.78
48.0	37.0	4.2	PQ1400480	36.09 x 3.53	41.00 x 1.78
50.0	39.0	4.2	PQ1400500	37.70 x 3.53	44.17 x 1.78
50.0	34.5	6.3	PQ1200500	32.69 x 5.33	44.17 x 1.78
52.0	41.0	4.2	PQ1400520	40.87 x 3.53	47.35 x 1.78
55.0	44.0	4.2	PQ1400550	44.04 x 3.53	50.52 x 1.78
60.0	49.0	4.2	PQ1400600	47.22 x 3.53	53.70 x 1.78
63.0	52.0	4.2	PQ1400630	50.39 x 3.53	56.87 x 1.78
63.0	47.5	6.3	PQ1200630	46.99 x 5.33	56.87 x 1.78
65.0	54.0	4.2	PQ1400650	53.57 x 3.53	60.05 x 1.78
70.0	59.0	4.2	PQ1400700	56.74 x 3.53	63.22 x 1.78
70.0	54.5	6.3	PQ1200700	53.34 x 5.33	63.22 x 1.78
75.0	64.0	4.2	PQ1400750	63.09 x 3.53	69.57 x 1.78
80.0	64.5	6.3	PQ1400800	53.34 x 5.33	72.75 x 1.78
80.0	59.0	8.1	PQ2200800	58 x 7.0	71.12 x 2.62
85.0	69.5	6.3	PQ1400850	69.22 x 5.33	75.92 x 1.78
85.0	64.0	8.1	PQ2200850	63 x 7.0	75.87 x 2.62
90.0	74.5	6.3	PQ1400900	72.39 x 5.33	82.27 x 1.78
90.0	69.0	8.1	PQ2200900	68 x 7.0	82.22 x 2.62
95.0	79.5	6.3	PQ1400950	78.74 x 5.33	88.62 x 1.78
95.0	74.0	8.1	PQ2200950	73 x 7.0	82.22 x 2.62
100.0	84.5	6.3	PQ1401000	81.92 x 5.33	88.62 x 1.78
100.0	79.0	8.1	PQ2201000	78 x 7.0	88.57 x 2.62
105.0	89.5	6.3	PQ1401050	88.27 x 5.33	94.97 x 1.78
105.0	84.0	8.1	PQ2201050	83 x 7.0	94.92 x 2.62
110.0	94.5	6.3	PQ1401100	91.44 x 5.33	101.32 x 1.78
110.0	89.0	8.1	PQ2201100	88 x 7.0	101.27 x 2.62
115.0	99.5	6.3	PQ1401150	97.79 x 5.33	107.67 x 1.78

The dimensions in bold type are suitable for grooves to ISO 7425/1. bore diameter in accordance with ISO 3320.

All intermediate sizes up to 700 mm diameter can be supplied. Sizes > 700 mm diameter with special elastomers on request.



Bore Diameter	Groove Diameter	Groove Width	Part No.	O-Ring Dimensions	QUAD-RING® Dimensions
D _N H9	d ₁ h9	L ₁ +0.2			
115.0	94.0	8.1	PQ2201150	93 x 7.0	107.62 x 2.62
120.0	104.5	6.3	PQ1401200	100.97 x 5.33	114.02 x 1.78
120.0	99.0	8.1	PQ2201200	98 x 7.0	107.62 x 2.62
125.0	109.5	6.3	PQ1401250	107.32 x 5.33	114.02 x 1.78
125.0	104.0	8.1	PQ2201250	103 x 7.0	113.97 x 2.62
130.0	114.5	6.3	PQ1401300	113.67 x 5.33	120.37 x 1.78
130.0	109.0	8.1	PQ2201300	108 x 7.0	120.32 x 2.62
135.0	114.0	8.1	PQ2401350	113.67 x 7.0	126.67 x 2.62
140.0	119.0	8.1	PQ2401400	116.84 x 7.0	126.67 x 2.62
150.0	129.0	8.1	PQ2401500	126.37 x 7.0	139.37 x 2.62
160.0	139.0	8.1	PQ2401600	135.89 x 7.0	145.72 x 2.62
170.0	149.0	8.1	PQ2401700	145.42 x 7.0	158.42 x 2.62
180.0	159.0	8.1	PQ2401800	158.12 x 7.0	171.11 x 2.62
190.0	169.0	8.1	PQ2401900	164.47 x 7.0	177.47 x 2.62
200.0	179.0	8.1	PQ2402000	177.17 x 7.0	190.17 x 2.62
210.0	189.0	8.1	PQ2402100	183.52 x 7.0	196.52 x 2.62
220.0	199.0	8.1	PQ2402200	196.22 x 7.0	202.87 x 2.62
230.0	209.0	8.1	PQ2402300	208.92 x 7.0	215.57 x 2.62
240.0	219.0	8.1	PQ2402400	215.27 x 7.0	221.92 x 2.62
250.0	229.0	8.1	PQ2402500	227.97 x 7.0	234.62 x 2.62
250.0	225.5	8.1	PQ2202500	227.97 x 7.0	234.62 x 2.62
280.0	252.0	9.5	PQ3202800	250 x 8.4	266.29 x 3.53
300.0	272.0	9.5	PQ3203000	270 x 8.4	278.99 x 3.53
310.0	282.0	9.5	PQ3203100	280 x 8.4	291.69 x 3.53
320.0	292.0	9.5	PQ3203200	290 x 8.4	304.39 x 3.53
350.0	322.0	9.5	PQ3203500	320 x 8.4	329.79 x 3.53
400.0	372.0	9.5	PQ3204000	370 x 8.4	380.59 x 3.53
420.0	392.0	9.5	PQ3204200	390 x 8.4	380.59 x 3.53
450.0	422.0	9.5	PQ3204500	420 x 8.4	430.66 x 3.53
480.0	445.0	11.5	PQ5204800	444 x 10.0	456.06 x 5.33
500.0	465.0	11.5	PQ5205000	464 x 10.0	456.06 x 5.33
600.0	565.0	11.5	PQ5206000	564 x 10.0	557.58 x 5.33
700.0	665.0	11.5	PQ5207000	664 x 10.0	658.88 x 5.33

The dimensions in bold type are suitable for grooves to ISO 7425/1. bore diameter in accordance with ISO 3320.

All intermediate sizes up to 700 mm diameter can be supplied. Sizes > 700 mm diameter with special elastomers on request.



POLYPAC[®] PHD SEAL

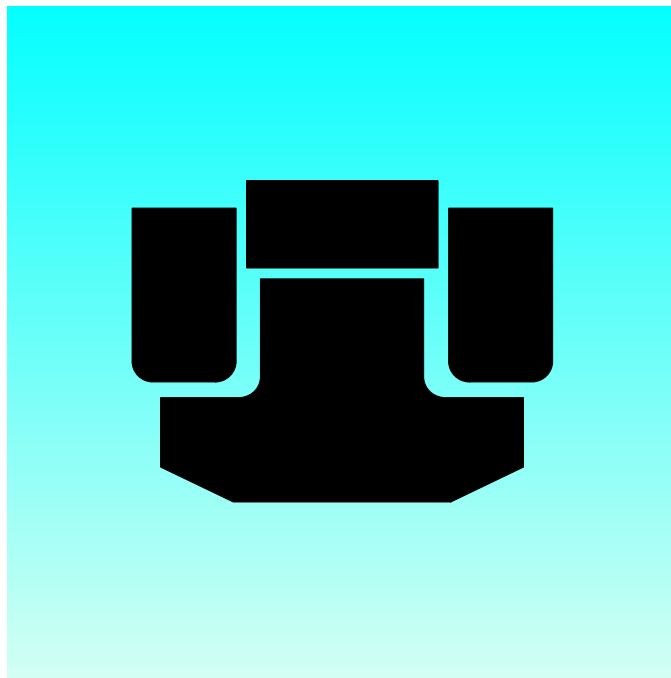

- Double Acting -

- Heavy Duty, High Pressure -

- Material -

- PTFE, NBR Elastomer, POM -





■ PHD Seal

Description

The PHD Seal is a high-pressure heavy-duty piston seal with excellent leakage control and superior extrusion and wear resistance

The PHD seal is a combination of a PTFE based slipper seal energised by an elastomer profile ring and completed with two Back-up rings (POM). It is manufactured with a predefined interference fit, which together with the squeeze of the elastomer part ensures a good sealing effect even at low system pressure. At higher pressures the elastomer part is energised by the system pressure and consequently activates the slipper seal in the radial direction.

The Back-up rings prevent the slipper seal from extrusion and ensure a long service life even under harsh conditions.

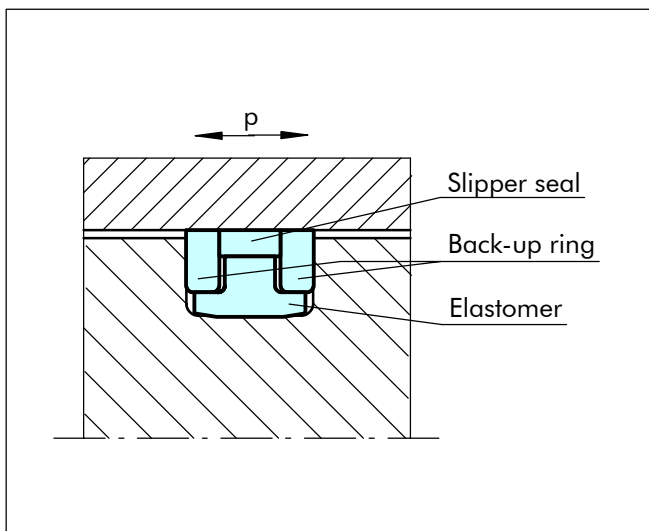

Figure 20 PHD Seal

Advantages

- Simple groove design
- No stick-slip effect when starting for smooth operation
- Minimum static and dynamic coefficient of friction
- Increased clearance possible
- Due to larger extrusion gap, safe use even with soiled media
- Long service life

Application Examples

The PHD Seal is the recommended sealing element for double acting pistons of hydraulic cylinders working in very harsh conditions such as:

- Excavators
- Heavy duty hydraulic cylinders

Technical Data

Operating conditions

pressure: Up to 40 MPa
Peak pressure up to 60 MPa

Speed: Up to 1.5 m/s

Temperature: -45°C to +135°C

Media: Mineral oil based hydraulic fluids, water/oil and glycol/oil emulsions

Clearance: The maximum permissible radial clearance S_{max} is shown in Table XXI, as a function of the operating pressure and functional diameter.

Important Note:

The above data are maximum values and cannot be used at the same time. e.g. the maximum operating speed depends on material type, pressure, temperature and gap value. Temperature range also dependent on medium.

Materials

Standard Application:

For hydraulic components:

- In mineral oils or medium with good lubricating performance
- in water /oil and water/glycol emulsions

Slipper Seal: Bronze filled PTFE

Energiser: NBR 80 Shore A

Back-up rings: POM

Material code for the set: PTNO4

Special Application:

For special applications requiring other material combinations, please contact your local Busak+Shamban Company.



Table XX Standard PTFE Based Materials for PHD Piston Seal

Material, Applications, Properties	Code	Energiser Material	Code	Energiser Operating Temp.* °C	Mating Surface Material	MPa max.
Material TR55 Standard material for hydraulics, good compressive strength, good sliding and wear properties, good extrusion resistance. Bronze filled Colour: Bronze to dark green	PT_04	NBR - 70 Shore A	N	-30 to +100	Steel tubes Steel, hardened Cast iron	40
		NBR - Low temp. 70 Shore A	T	-45 to +80		
		FKM - 70 Shore A	V	-10 to +135#		
Material TR12 For all lubricating fluids, hard mating surfaces, good sliding properties, low friction Colour pigment filled Colour: Dark green	PT_0A	NBR - 70 Shore A	N	-30 to +100	Steel tubes Steel, hardened	40
		NBR - Low temp. 70 Shore A	T	-45 to +80		
		FKM - 70 Shore A	V	-10 to +135#		
Material TR25 For all lubricating and non-lubricating hydraulic fluids, good chemical resistance, good dielectric properties. Glass fibre filled+graphite+MoS2 Colour: Grey to blue	PT_0J	NBR - 70 Shore A	N	-30 to +100	Steel tubes Steel, hardened Cast iron	40
		NBR - Low temp. 70 Shore A	T	-45 to +80		
		FKM - 70 Shore A	V	-10 to +135#		
Material TR30 For water hydraulic, oil hydraulic and pneumatic for all lubricating and non-lubricating fluids, high extrusion resistance, good chemical resistance. Carbon, graphite filled Colour: Black	PT_0C	NBR - 70 Shore A	N	-30 to +100	Steel Stainless steel	40
		NBR - Low temp. 70 Shore A	T	-45 to +80		
		FKM - 70 Shore A	V	-10 to +135#		
		EPDM - 70 Shore A	E**	-45 to +135#		

Limited high temperature due to POM Back-up Ring.

* The Energiser Operation Temperature is only valid in mineral hydraulic oil.

Highlighted material is standard.

**Material not suitable for mineral oils.

Material Code definition:

PHD seal with slipper seal material TR55 and NBR energiser:

PTN04



■ Installation Recommendation

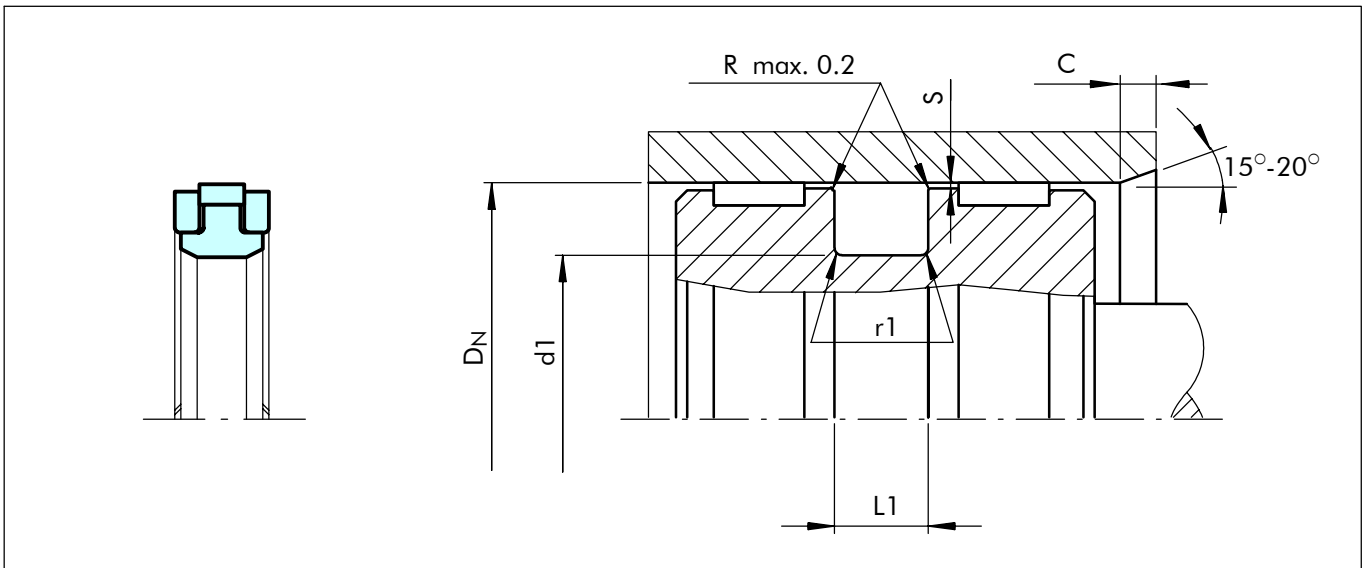

Figure 21 Installation drawing

Table XXI Installation dimensions / Part No.

Bore Dia.	Groove Dia.	Groove Width	Inlet Chamfer	Radius	Radial Clearance	Part No	Polypac Ref. No.
D_N H9	$d1$ h9	$L1$ +0.2	C	$r1$	S		
50.0	36.0	9.0	5.0	0.3	For pressure up to 35 MPa 0.50	PKP000500	PHD 5036
55.0	41.0	9.0	5.0	0.3		PKP000550	PHD 5541
60.0	46.0	9.0	5.0	0.3		PKP000600	PHD 6046
63.0	48.0	11.0	5.0	0.5		PKP000630	PHD 6348
65.0	50.0	11.0	5.0	0.5		PKP000650	PHD 6550
70.0	55.0	11.0	5.0	0.5		PKP000700	PHD 7055
75.0	60.0	11.0	5.0	0.5		PKP000750	PHD 7560
80.0	65.0	11.0	5.0	0.5		PKP000800	PHD 8065
85.0	70.0	11.0	5.0	0.5		PKP000850	PHD 8570
90.0	75.0	11.0	5.0	0.5		PKP000900	PHD 9075
95.0	80.0	12.5	5.0	0.5	For pressure from 35 MPa up to 60 MPa 0.30	PKP000950	PHD 9580
100.0	85.0	12.5	5.0	0.5		PKP001000	PHD 10085
105.0	90.0	12.5	5.0	0.5		PKP001050	PHD 10590
110.0	95.0	12.5	5.0	0.5		PKP001100	PHD 11095
115.0	100.0	12.5	5.0	0.5		PKP001150	PHD 115100
120.0	105.0	12.5	5.0	0.5		PKP001200	PHD 120105
125.0	102.0	16.0	6.5	0.6		PKP001250	PHD 125102
130.0	107.0	16.0	6.5	0.6		PKP001300	PHD 130107
135.0	112.0	16.0	6.5	0.6		PKP001350	PHD 135112
140.0	117.0	16.0	6.5	0.6		PKP001400	PHD 140117
145.0	122.0	16.0	6.5	0.6	PKP001450	PHD 145122	
150.0	127.0	16.0	6.5	0.6	PKP001500	PHD 150127	
155.0	132.0	16.0	6.5	0.6	PKP001550	PHD 155132	
160.0	137.0	16.0	6.5	0.6	PKP001600	PHD 160137	
165.0	142.0	16.0	6.5	0.6	PKP001650	PHD 165142	
170.0	147.0	16.0	6.5	0.6	PKP001700	PHD 170147	
180.0	157.0	16.0	6.5	0.6	PKP001800	PHD 180157	



Ordering Example

PHD Seal, complete.

Bore diameter: $D_N = 80.0$ mm

Part No.: PKP000800 (from Table XXI)

Seal: PTFE TR55

Energiser: NBR

Back-up ring: POM

Material set-code: PTN04

Polypac Ref. No.: PHD 8065

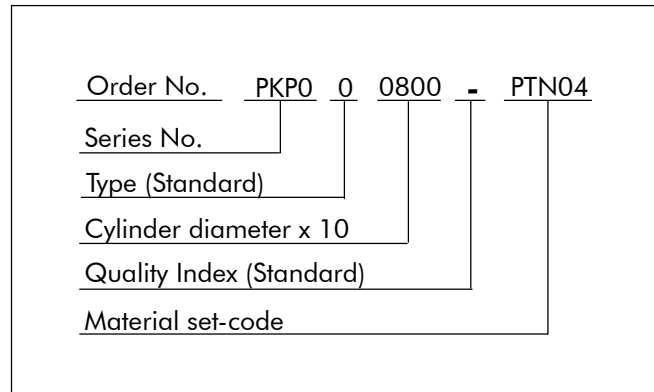

TURCON[®] STEPSEAL[®] 2K

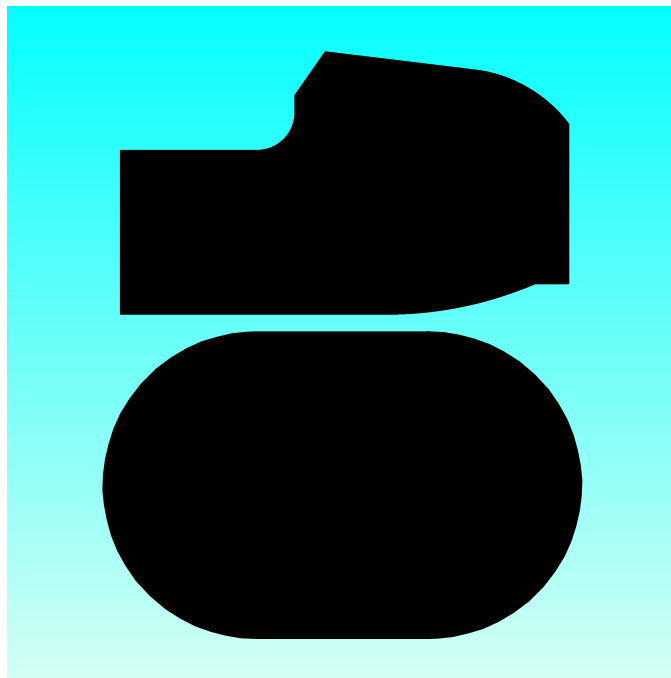

- Single Acting -

- Rubber Energised Plastic Faced Seal -

- Material -

- Turcon[®], Zurcon[®] and Elastomer -





■ Turcon® Stepseal® 2K*

Description

The Stepseal® 2K is a single-acting seal element consisting of a seal ring of high-grade Turcon® or Zurcon® materials and an O-Ring as energizing element.

The Stepseal® 2K was originally developed and patented by Busak+Shamban as a rod seal. Due to its outstanding properties, however, it is equally well suited as a single-acting piston seal where high demands are made on positional accuracy and free movement.

* Patented and patent pending geometry

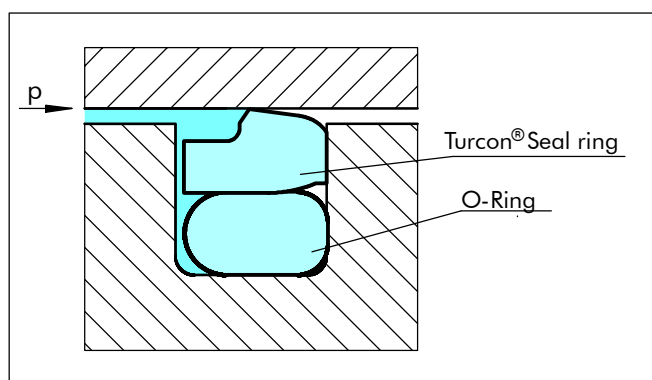

Figure 22 Turcon® Stepseal® 2K

Advantages

- High static and dynamic sealing effect
- Stick-slip free operation for precise control
- High abrasion resistance and high resistance to extrusion
- Long service life
- Simple groove design, one-piece piston possible
- Wide range of application temperatures and high resistance to chemicals, depending on the choice of O-Ring material
- Simple installation without seal edge deformation
- Available for all diameters up to 2.700 mm
- Low friction

Application Examples

The Turcon® Stepseal® 2K is the recommended sealing element for single acting pistons in hydraulic components for:

- Injection moulding machines
- Machine tools
- Presses

It is particularly recommended in floating piston accumulators as primary seal on the oil side in combination with AQ-Seal® and AQ-Seal® 5.

Technical Data

Operating conditions	
pressure:	Up to 80 MPa
Speed:	Up to 15 m/s, frequency up to 5 Hz
Temperature:	-45°C to +200°C *)
Media:	Mineral oil-based hydraulic fluids, flame retardant hydraulic fluids, environmentally safe hydraulic fluids (bio-oils), water, air and others, depending on the O-Ring material (see Table XXIII)
Clearance:	The maximum permissible radial clearance S_{max} is shown in Table XXIV, as a function of the operating pressure and functional diameter.

Important Note:

The above data are maximum values and cannot be used at the same time. e.g. the maximum operating speed depends on material type, pressure, temperature and gap value. Temperature range also dependent on medium.

*) In the case of unpressurized applications in temperatures below 0°C please contact our application engineers for assistance !



Materials

Standard Application:

- For hydraulic components in mineral oils containing zinc or medium with good lubricating performance.

Turcon® Seal: Turcon® T46

Energiser: O-Ring NBR 70 Shore A or FKM 70 Shore A depending on the temperature

Set reference: T46 N or T46 V

Special Application:

- Non-lubricating fluids or pneumatic applications require self-lubricating sealing materials. Therefore we recommend:

Turcon® Seal: Turcon® T29

Energiser: O-Ring NBR 70 Shore A or FKM 70 Shore A depending on the temperature

Set reference: T29 N or T29 V

- Rough mating surface finish and improved leakage control

Zurcon® Seal: Zurcon® Z51

Energiser: O-Ring NBR 70 Shore A

Set reference: Z51 N

Series

Different cross-section sizes are recommended as a function of the seal diameters. These are the criteria for these recommendations.

Table XXIV, shows the relationship between the series number according to the seal diameter range and the different application class sizes. These application classes are:

Standard application: General applications in which no exceptional operating conditions exist.

Light application: Applications with demands for reduced friction or for smaller grooves.

Heavy-duty application: For exceptional operating loads such as high pressures, pressure peaks, etc.

Table XXII Available range

Series No.	Bore Diameter D _N H9
PSK00	6.0 - 140.0
PSK10	10.0 - 140.0
PSK20	18.0 - 320.0
PSK30	40.0 - 400.0
PSK40	50.0 - 700.0
PSK80	133.0 - 999.9
PSK50	250.0 - 999.9
PSK5X	1000.0 - 1200.0
PSK60	750.0 - 999.9
PSK6X	1000.0 - 2700.0

For the recommended range see Table XXIV

Groove

Stepseal® 2K are also available on request for the groove sizes to ISO 7425/1.



Table XXIII Turcon® and Zurcon® materials for Stepseal® 2K

Material, Applications, Properties	Code	O-Ring Material	Code	O-Ring Operating Temp.* °C	Mating Surface Material	MPa max.
Turcon® T46 Standard material for hydraulics, high compressive strength, good sliding and wear properties, good extrusion resistance, BAM tested. Bronze filled Colour: Greyish to dark brown	T46	NBR-70 Shore A	N	-30 to +100	Steel tube Steel, hardened Cast iron	70
		NBR-Low temp. 70 Shore A	T	-45 to +80		
		FKM-70 Shore A	V	-10 to +200		
Turcon® T08 Very high compressive strength, very good extrusion resistance. High bronze filled Colour: Light to dark brown	T08	NBR-70 Shore A	N	-30 to +100	Steel tube Steel, hardened Cast iron	80
		NBR-Low temp. 70 Shore A	T	-45 to +80		
		FKM-70 Shore A	V	-10 to +200		
Turcon® T40 For all lubricating and non-lubricating hydraulic fluids, water hydraulic, soft mating surfaces. Carbon fibre filled Colour: Grey	T40	NBR-70 Shore A	N	-30 to +100	Steel Cast iron Stainless steel Aluminium Bronze Alloys	30
		NBR-Low temp. 70 Shore A	T	-45 to +80		
		FKM-70 Shore A	V	-10 to +200		
		EPDM-70 Shore A	E**	-45 to +145		
Turcon® T29 For all lubricating and non-lubricating hydraulic fluids, hydraulic oils without zinc, soft mating surfaces, good extrusion resistance. High carbon fibre filled Colour: Grey	T29	NBR-70 Shore A	N	-30 to +100	Steel Cast iron Stainless steel Aluminium Bronze	70
		NBR-Low temp. 70 Shore A	T	-45 to +80		
		FKM-70 Shore A	V	-10 to +200		
		EPDM-70 Shore A	E**	-45 to +145		
Turcon® T05 For all lubricating hydraulic fluids, hard mating surfaces, very good slide properties, low friction. Colour: Turquoise	T05	NBR-70 Shore A	N	-30 to +100	Steel tube Steel, hardened	25
		NBR-Low temp. 70 Shore A	T	-45 to +80		
		FKM-70 Shore A	V	-10 to +200		
Turcon® T42 For all lubricating and non-lubricating hydraulic fluids, good chemical resistance, good dielectric properties. Glass fibre filled + MoS ₂ Colour: Grey to blue	T42	NBR-70 Shore A	N	-30 to +100	Steel tube Steel, hardened Cast iron	40
		NBR-Low temp. 70 Shore A	T	-45 to +80		
		FKM-70 Shore A	V	-10 to +200		
Turcon® T10 For oil hydraulic and pneumatic, for all lubricating and non-lubricating fluids, high extrusion resistance, good chemical resistance, BAM tested. Carbon, graphite filled Colour: Black	T10	NBR-70 Shore A	N	-30 to +100	Steel Stainless steel	70
		NBR-Low temp. 70 Shore A	T	-45 to +80		
		FKM-70 Shore A	V	-10 to +200		
		EPDM-70 Shore A	E**	-45 to +145		
Zurcon® Z51*** For lubricating hydraulic fluids, high abrasion resistance, high extrusion resistance, limited chemical resistance. Cast polyurethane Colour: Yellow to light-brown	Z51	NBR-70 Shore A	N	-30 to +100	Steel Steel, hardened Cast iron Ceramic coating Stainless steel	80
		NBR-Low temp. 70 Shore A	T	-45 to +80		
Zurcon® Z80 For lubricating and non-lubricating hydraulic fluids, high abrasion resistance, very good chemical resistance, limited temp. resistance. Ultra high molecular weight polyethylen Colour: White to off-white	Z80	NBR-70 Shore A	N	-30 to +80	Steel Stainless steel Aluminium Bronze Ceramic coating	45
		NBR-Low temp. 70 Shore A	T	-45 to +80		

* The O-Ring Operation Temperature is only valid in mineral hydraulic oil. BAM: Tested by "Bundes-anstalt Materialprüfung, Germany".
 [] Highlighted materials are standard. ** Material not suitable for mineral oils. *** max. Ø 2300 mm



Installation Recommendation

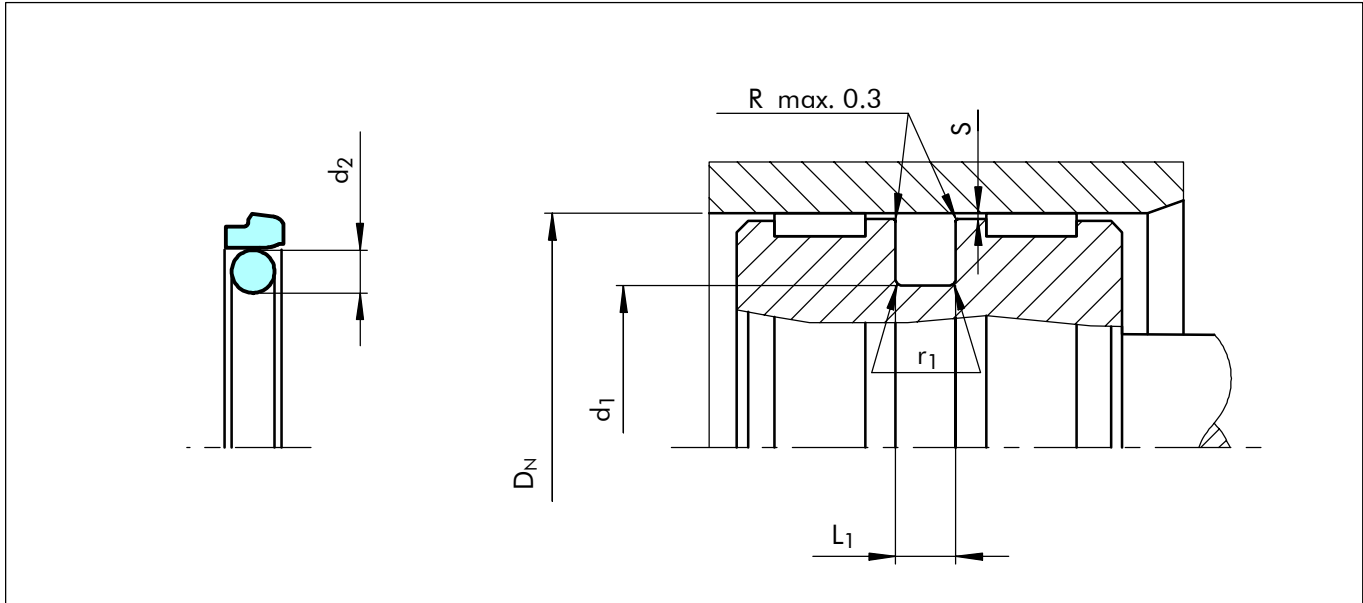

Figure 23 Installation drawing

Table XXIV Installation dimensions - Standard recommendations

Series No.	Bore Diameter			Groove Diameter	Groove Width	Radius	Radial Clearance			O-Ring Cross-Section
	D _N H9						S max*			
	Standard Application	Light Application	Heavy-Duty Application	d ₁ h9	L ₁ +0,2	r ₁	10 MPa	20 MPa	40 MPa	d ₂
PSK0	8 - 16.9	17 - 26.9	- -	D _N -4.9	2.2	0.4	0.30	0.20	0.15	1.78
PSK1	17 - 26.9	27 - 59.9	- -	D _N -7.3	3.2	0.6	0.40	0.25	0.15	2.62
PSK2	27 - 59.9	60 - 199.9	17 - 26.9	D _N -10.7	4.2	1.0	0.50	0.30	0.20	3.53
PSK3	60 - 199.9	200 - 255.9	27 - 59.9	D _N -15.1	6.3	1.3	0.70	0.40	0.25	5.33
PSK4	200 - 255.9	256 - 669.9	60 - 199.9	D _N -20.5	8.1	1.8	0.80	0.60	0.35	7.00
PSK8	256 - 669.9	670 - 999.9	200 - 255.9	D _N -24.0	8.1	1.8	0.90	0.70	0.40	7.00
PSK5	670 - 999.9	≥ 1000	256 - 669.9	D _N -27.3	9.5	2.5	1.00	0.80	0.50	8.40
PSK6	≥ 1000**	- -	670 - 999.9	D _N -38.0	13.8	3.0	1.20	0.90	0.60	12.00

* At pressures > 40 MPa use diameter tolerance H8/f8 (bore/piston) in area of seal

** Energiser has a special shape.

Ordering example

Turcon® Stepseal® 2K, complete with O-Ring, standard application, Series PSK3 (from Table XXIV).

Bore diameter: D_N = 80.0 mm

Part No. PSK300800 (from Table XXV)

Select the material from Table XXIII. The corresponding code numbers are appended to the Part No. (from Table XXV). Together they form the Order No.

For all intermediate sizes not shown in Table XXV, the Order No. can be determined from the example opposite.

*** For diameters ≥ 1000.0 mm multiply only by factor 1.

Example: PSK6 for diameter 1200.0 mm.

Order no.: PSK6X1200 - T46N.

Order No.	PSK3	0	0800	-	T46	N
Series No.						
Type (Standard)						
Cylinder diameter x 10***						
Quality Index (Standard)						
Material code (Seal ring)						
Material code (O-Ring)						



Table XXV Installation dimensions / Part No.

Bore Dia.	Groove Dia.	Groove Width	Part No.	O-Ring Dimensions
D _N H9	d ₁ h9	L ₁ +0.2		
9.0	4.1	2.2	PSK000090	3.68 x 1.78
10.0	5.1	2.2	PSK000100	4.80 x 1.8
12.0	7.1	2.2	PSK000120	6.70 x 1.8
14.0	9.1	2.2	PSK000140	8.75 x 1.8
15.0	10.1	2.2	PSK000150	9.25 x 1.78
16.0	11.1	2.2	PSK000160	10.82 x 1.78
18.0	10.7	3.2	PSK100180	9.19 x 2.62
20.0	15.1	2.2	PSK000200	14.00 x 1.78
20.0	12.7	3.2	PSK100200	12.37 x 2.62
22.0	14.7	3.2	PSK100220	13.94 x 2.62
25.0	17.7	3.2	PSK100250	17.12 x 2.62
25.0	14.3	4.2	PSK200250	13.87 x 3.53
28.0	17.3	4.2	PSK200280	15.47 x 3.53
30.0	22.7	3.2	PSK100300	21.89 x 2.62
30.0	19.3	4.2	PSK200300	18.66 x 3.53
32.0	24.7	3.2	PSK100320	23.47 x 2.62
32.0	21.3	4.2	PSK200320	20.22 x 3.53
35.0	24.3	4.2	PSK200350	23.40 x 3.53
40.0	32.7	3.2	PSK100400	31.42 x 2.62
40.0	29.3	4.2	PSK200400	28.17 x 3.53
42.0	31.3	4.2	PSK200420	29.75 x 3.53
45.0	34.3	4.2	PSK200450	32.92 x 3.53
48.0	37.3	4.2	PSK200480	36.09 x 3.53
50.0	39.3	4.2	PSK200500	37.70 x 3.53
50.0	34.9	6.3	PSK300500	32.69 x 5.33
52.0	41.3	4.2	PSK200520	40.87 x 3.53
55.0	44.3	4.2	PSK200550	44.04 x 3.53
60.0	44.9	6.3	PSK300600	43.82 x 5.33
63.0	52.3	4.2	PSK200630	50.39 x 3.53
63.0	47.9	6.3	PSK300630	46.99 x 5.33
65.0	49.9	6.3	PSK300650	46.99 x 5.33
70.0	59.3	4.2	PSK200700	56.74 x 3.53
70.0	54.9	6.3	PSK300700	53.34 x 5.33
75.0	59.9	6.3	PSK300750	56.52 x 5.33
80.0	64.9	6.3	PSK300800	62.87 x 5.33
80.0	59.5	8.1	PSK400800	58 x 7.0
85.0	69.9	6.3	PSK300850	69.22 x 5.33
85.0	64.5	8.1	PSK400850	63 x 7.0
90.0	74.9	6.3	PSK300900	72.39 x 5.33
90.0	69.5	8.1	PSK400900	68 x 7.0
95.0	79.9	6.3	PSK300950	78.74 x 5.33
95.0	74.5	8.1	PSK400950	73 x 7.0

Bore Dia.	Groove Dia.	Groove Width	Part No.	O-Ring Dimensions
D _N H9	d ₁ h9	L ₁ +0.2		
100.0	84.9	6.3	PSK301000	81.92 x 5.33
100.0	79.5	8.1	PSK401000	78 x 7.0
105.0	89.9	6.3	PSK301050	88.27 x 5.33
105.0	84.5	8.1	PSK401050	83 x 7.0
106.0	90.9	6.3	PSK301060	88.27 x 5.33
110.0	94.9	6.3	PSK301100	91.44 x 5.33
110.0	89.5	8.1	PSK401100	88 x 7.0
115.0	99.9	6.3	PSK301150	97.79 x 5.33
115.0	94.5	8.1	PSK401150	93 x 7.0
120.0	104.9	6.3	PSK301200	104.14 x 5.33
120.0	99.5	8.1	PSK401200	98 x 7.0
125.0	109.9	6.3	PSK301250	107.32 x 5.33
125.0	104.5	8.1	PSK401250	103 x 7.0
130.0	114.9	6.3	PSK301300	113.67 x 5.33
130.0	109.5	8.1	PSK401300	108 x 7.0
135.0	114.5	8.1	PSK401350	113.67 x 7.0
140.0	119.5	8.1	PSK401400	116.84 x 7.0
145.0	124.5	8.1	PSK401450	123.19 x 7.0
150.0	129.5	8.1	PSK401500	126.37 x 7.0
155.0	139.9	6.3	PSK301550	135.89 x 5.33
160.0	144.9	6.3	PSK301600	142.24 x 5.33
160.0	139.5	8.1	PSK401600	135.89 x 7.00
165.0	149.9	6.3	PSK301650	148.49 x 5.33
165.0	144.5	8.1	PSK401650	142.24 x 7.0
170.0	149.5	8.1	PSK401700	145.42 x 7.0
175.0	159.9	6.3	PSK301750	158.12 x 5.33
180.0	164.9	6.3	PSK301800	164.47 x 5.33
180.0	159.5	8.1	PSK401800	158.12 x 7.0
190.0	174.9	6.3	PSK301900	170.82 x 5.33
190.0	169.5	8.1	PSK401900	164.47 x 7.0
200.0	184.9	6.3	PSK302000	183.52 x 5.33
200.0	179.5	8.1	PSK402000	177.17 x 7.0
205.0	184.5	8.1	PSK402050	183.52 x 7.0
210.0	189.5	8.1	PSK402100	183.52 x 7.0
220.0	204.9	6.3	PSK302200	202.57 x 5.33
220.0	199.5	8.1	PSK402200	196.22 x 7.0
230.0	209.5	8.1	PSK402300	208.92 x 7.0
240.0	219.5	8.1	PSK402400	215.27 x 7.0
250.0	229.5	8.1	PSK402500	227.97 x 7.0
250.0	226.0	8.1	PSK802500	227.97 x 7.0
260.0	236.0	8.1	PSK802600	227.97 x 7.0
270.0	246.0	8.1	PSK802700	240.67 x 7.0



Bore Dia.	Groove Dia.	Groove Width	Part No.	O-Ring* Dimensions
D_N H9	d_1 h9	$L_1 +0.2$		
280.0	256.0	8.1	PSK802800	253.37 x 7.0
300.0	276.0	8.1	PSK803000	266.07 x 7.0
306.0	285.5	8.1	PSK403060	278.77 x 7.0
310.0	286.0	8.1	PSK803100	278.77 x 7.0
320.0	299.5	8.1	PSK403200	291.47 x 7.0
320.0	296.0	8.1	PSK803200	291.47 x 7.0
330.0	306.0	8.1	PSK803300	304.17 x 7.0
340.0	316.0	8.1	PSK803400	316.87 x 7.0
345.0	324.5	8.1	PSK403450	316.87 x 7.0
350.0	326.0	8.1	PSK803500	316.87 x 7.0
360.0	336.0	8.1	PSK803600	329.57 x 7.0
370.0	346.0	8.1	PSK803700	342.27 x 7.0
380.0	356.0	8.1	PSK803800	354.97 x 7.0
400.0	376.0	8.1	PSK804000	367.67 x 7.0
420.0	396.0	8.1	PSK804200	393.07 x 7.0
430.0	406.0	8.1	PSK804300	405.26 x 7.0
440.0	416.0	8.1	PSK804400	405.26 x 7.0
450.0	426.0	8.1	PSK804500	417.96 x 7.0
480.0	456.0	8.1	PSK804800	456.06 x 7.0
500.0	476.0	8.1	PSK805000	468.76 x 7.0
520.0	499.5	8.1	PSK405200	494.16 x 7.0
540.0	516.0	8.1	PSK805400	506.86 x 7.0
600.0	576.0	8.1	PSK806000	557.66 x 7.0
650.0	626.0	8.1	PSK806500	608.08 x 7.0
700.0	672.7	9.5	PSK507000	670 x 8.4
800.0	772.7	9.5	PSK508000	770 x 8.4
860.0	832.7	9.5	PSK508600	830 x 8.4
900.0	872.7	9.5	PSK509000	870 x 8.4
920.0	892.7	9.5	PSK509200	890 x 8.4
1000.0	972.7	9.5	PSK5X1000	970 x 8.4
1000.0	962.0	13.8	PSK6X1000	960 x 12.0
1200.0	1172.7	9.5	PSK5X1200	1170 x 8.4
1200.0	1162.0	13.8	PSK6X1200	1160 x 12.0
1500.0	1462.0	13.8	PSK6X1500	1460 x 12.0
2000.0	1962.0	13.8	PSK6X2000	1960 x 12.0
2700.0	2662.0	13.8	PSK6X2700	2660 x 12.0

The bore diameters in **bold** type comply with the recommendations of ISO 3320.

Other dimensions and all intermediate sizes up to 2700 mm diameter including imperial (inch) sizes can be supplied.

All O-Rings with 12 mm cross section are delivered as special Profiling.

TURCON[®] STEPSEAL[®] K

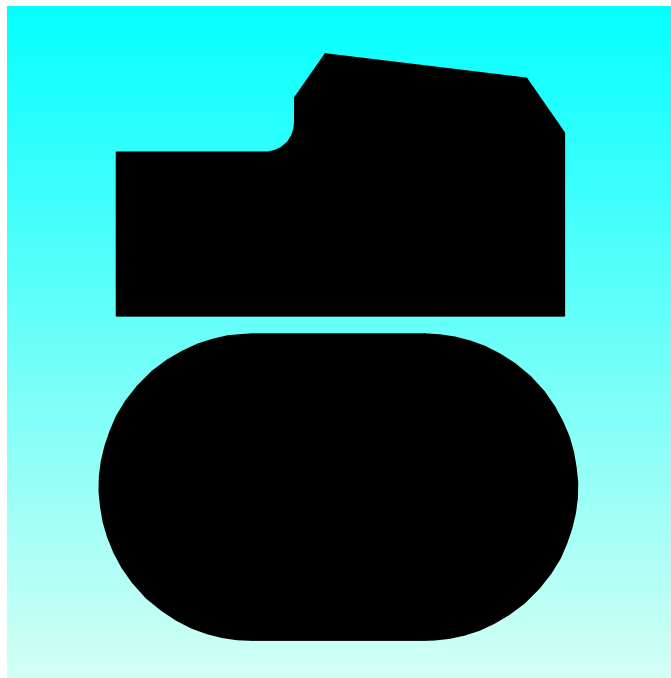

- Single Acting -

- Rubber Energised Plastic Faced Seal -

- Material -

- Turcon[®], Zurcon[®] and Elastomer -





■ Turcon® Stepseal® K

Description

The Stepseal® K is a single-acting seal element consisting of a seal ring of high-grade Turcon® or Zurcon® materials and an O-Ring as energizing element.

The Stepseal® K was originally developed and patented (Patent No. P3225906) by Busak+Shamban as a rod seal. Due to its outstanding properties, however, it is equally well suited as a single-acting piston seal where high demands are made on positional accuracy and free movement.

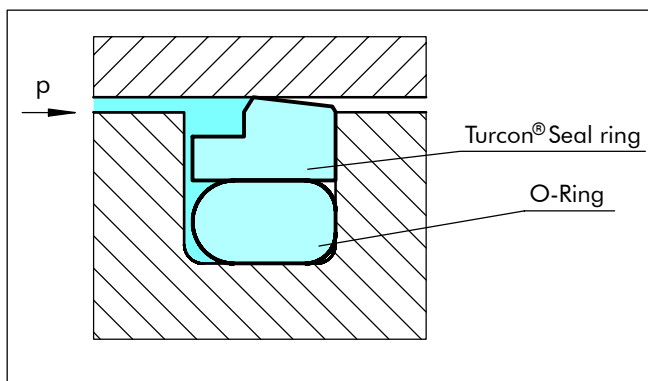

Figure 24 Turcon® Stepseal® K

Advantages

- High static and dynamic sealing effect
- Stick-slip free operation for precise control
- High abrasion resistance and resistance to extrusion
- Long service life
- Simple groove design, one-piece piston possible
- Wide range of application temperatures and high resistance to chemicals, depending on the choice of O-Ring material
- Simple installation without seal edge deformation due to the K-edge
- Available for all diameters up to 2.700 mm

Application Examples

The Turcon® Stepseal® K is the recommended sealing element for single acting pistons in hydraulic components for:

- Injection moulding machines
- Machine tools
- Presses

It is particularly recommended in floating piston accumulators as primary seal on the oil side in combination with AQ-Seal® and AQ-Seal® 5.

Technical Data

Operating conditions

pressure: Up to 80 MPa

Speed: Up to 15 m/s, frequency up to 5 Hz

Temperature: -45°C to +200°C *)

Media: Mineral oil-based hydraulic fluids, flame retardant hydraulic fluids, environmentally safe hydraulic fluids (bio-oils), water, air and others, depending on the O-Ring material (see Table XXVI)

Clearance: The maximum permissible radial clearance S_{max} is shown in Table XXVII, as a function of the operating pressure and functional diameter.

Important Note:

The above data are maximum values and cannot be used at the same time. e.g. the maximum operating speed depends on material type, pressure, temperature and gap value. Temperature range also dependent on medium.

*) In the case of unpressurized applications in temperatures below 0°C please contact our application engineers for assistance !



Materials

Standard Application:

- For hydraulic components in mineral oils containing zinc or medium with good lubricating performance.

Turcon[®] Seal: Turcon[®] T46

Energiser: O-Ring NBR 70 Shore A or FKM 70 Shore A depending on the temperature

Set reference: T46 N or T46 V

Special Application:

- Non-lubricating fluids or pneumatic applications require self-lubricating sealing materials. Therefore we recommend:

Turcon[®] Seal: Turcon[®] T29

Energiser: O-Ring NBR 70 Shore A or FKM 70 Shore A depending on the temperature

Set reference: T29 N or T29 V

- Rough mating surface finish and improved leakage control

Zurcon[®] Seal: Zurcon[®] Z51

Energiser: O-Ring NBR 70 Shore A

Set reference: Z51 N

Groove

Stepseal[®] K are also available on request for the groove sizes to ISO 7425/1.



Table XXVI Turcon® and Zurcon® Materials for Stepseal® K

Material, Applications, Properties	Code	O-Ring Material	Code	O-Ring Operating Temp.* °C	Mating Surface Material	MPa max.
Turcon® T46 Standard material for hydraulics, high compressive strength, good sliding and wear properties, good extrusion resistance, BAM tested. Bronze filled Colour: Greyish to dark brown	T46	NBR - 70 Shore A	N	-30 to +100	Steel tubes Steel, hardened Cast iron	60
		NBR - Low temp. 70 Shore A	T	-45 to +80		
		FKM - 70 Shore A	V	-10 to +200		
Turcon® T08 Very high compressive strength, very good extrusion resistance. High bronze filled Colour: Light to dark brown	T08	NBR - 70 Shore A	N	-30 to +100	Steel tubes Steel, hardened Cast iron	80
		NBR - Low temp. 70 Shore A	T	-45 to +80		
		FKM - 70 Shore A	V	-10 to +200		
Turcon® T40 For all lubricating and non-lubricating hydraulic fluids, water hydraulic, soft mating surfaces. Carbon fibre filled Colour: Grey	T40	NBR - 70 Shore A	N	-30 to +100	Steel Cast iron Stainless steel Aluminium Bronze Alloys	25
		NBR - Low temp. 70 Shore A	T	-45 to +80		
		FKM - 70 Shore A	V	-10 to +200		
		EPDM-70 Shore A	E**	-45 to +145		
Turcon® T29 For all lubricating and non-lubricating hydraulic fluids, hydraulic oils without zinc, soft mating surfaces, good extrusion resistance. High carbon fibre filled Colour: Grey	T29	NBR - 70 Shore A	N	-30 to +100	Steel Cast iron Stainless steel Aluminium Bronze	60
		NBR - Low temp. 70 Shore A	T	-45 to +80		
		FKM - 70 Shore A	V	-10 to +200		
		EPDM-70 Shore A	E**	-45 to +145		
Turcon® T05 For all lubricating hydraulic fluids, hard mating surfaces, very good sliding properties, low friction. Colour: Turquoise	T05	NBR - 70 Shore A	N	-30 to +100	Steel tubes Steel, hardened	20
		NBR - Low temp. 70 Shore A	T	-45 to +80		
		FKM - 70 Shore A	V	-10 to +200		
Turcon® T42 For all lubricating and non-lubricating hydraulic fluids, good chemical resistance, good dielectric properties. Glass fibre filled + MoS ₂ Colour: Grey to blue	T42	NBR - 70 Shore A	N	-30 to +100	Steel tubes Steel, hardened Cast iron	30
		NBR - Low temp. 70 Shore A	T	-45 to +80		
		FKM - 70 Shore A	V	-10 to +200		
Turcon® T10 For oil hydraulic and pneumatic, for all lubricating and non-lubricating fluids, high extrusion resistance, good chemical resistance, BAM tested. Carbon, graphite filled Colour: Black	T10	NBR - 70 Shore A	N	-30 to +100	Steel Stainless steel	60
		NBR - Low temp. 70 Shore A	T	-45 to +80		
		FKM - 70 Shore A	V	-10 to +200		
		EPDM-70 Shore A	E**	-45 to +145		
Zurcon® Z51*** For lubricating hydraulic fluids, high abrasion resistance, high extrusion resistance, limited chemical resistance. Cast polyurethane Colour: Yellow to light-brown	Z51	NBR - 70 Shore A	N	-30 to +100	Steel Steel, hardened Cast iron Ceramic coating Stainless steel	80
		NBR - Low temp. 70 Shore A	T	-45 to +80		
Zurcon® Z80 For lubricating and non-lubricating hydraulic fluids, high abrasion resistance, very good chemical resistance, limited temperature resistance. Ultra high molecular weight polyethylen Colour: White to off-white	Z80	NBR - 70 Shore A	N	-30 to +80	Steel Stainless steel Aluminium Bronze Ceramic coating	40
		NBR - Low temp. 70 Shore A	T	-45 to +80		

* The O-Ring Operation Temperature is only valid in mineral hydraulic oil. BAM: Tested by "Bundes Anstalt Materialprüfung, Germany".

Highlighted materials are standard. **Material not suitable for mineral oils. *** max. Ø 2300 mm



■ Installation Recommendation (for new Constructions please apply Turcon® Stepseal® 2K)

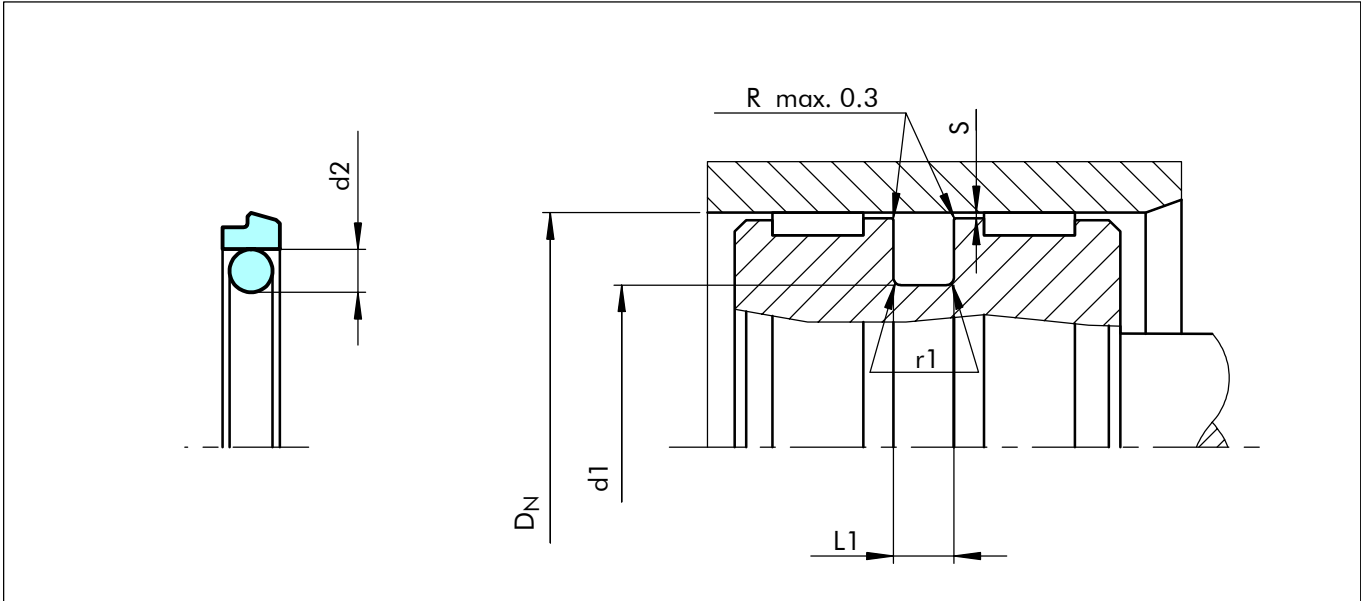

Figure 25 Installation drawing

Table XXVII Installation Dimensions - Standard Recommendations

Bore Diameter DN H9			Groove Diameter	Groove Width	Radius	Radial Clearance S max*			O-Ring Cross Sec.
Series No. PS 14 Standard Application	Series No. PS 16 Light Application	Series No. PS 12 Heavy-Duty Application	d ₁ h9	L ₁ +0.2	r ₁	10 MPa	20 MPa	40 MPa	d ₂
8 - 16.9	17 - 26.9	--	DN-4.9	2.2	0.4	0.30	0.20	0.15	1.78
17 - 26.9	27 - 59.9	--	DN-7.3	3.2	0.6	0.40	0.25	0.15	2.62
27 - 59.9	60 - 199.9	17 - 26.9	DN-10.7	4.2	1.0	0.40	0.25	0.20	3.53
60 - 199.9	200 - 255.9	27 - 59.9	DN-15.1	6.3	1.3	0.50	0.30	0.20	5.33
200 - 255.9	256 - 669.9	60 - 199.9	DN-20.5	8.1	1.8	0.60	0.35	0.25	7.00
256 - 669.9	670 - 999.9	200 - 255.9	DN-24.0	8.1	1.8	0.60	0.35	0.25	7.00
670 - 999.9	--	256 - 669.9	DN-27.3	9.5	2.5	0.70	0.50	0.30	8.40
≥ 1000**			DN-38.0	13.8	3.0	1.00	0.70	0.60	12.00

* At pressures > 40 MPa use diameter tolerance H8/f8 (bore/piston) in area of the seal.

** Energiser has a special shape.

Ordering Example

Turcon® Stepseal® K, complete with O-Ring, standard application, Series PS14 (from Table XXVII).
 Bore diameter: DN = 80.0 mm
 Part No. PS1400800 (from Table XXVIII)

Select the material from Table XXVI. The corresponding code numbers are appended to the Part No. (from Table XXVIII). Together they form the Order No.
 For all intermediate sizes not shown in Table XXVIII, the Order No. can be determined from the example opposite.

*** For diameters ≥ 1000.0 mm multiply only by factor 1.
 Example: PS14 for diameter 1200.0 mm.
 Order no.: PS14X1200 - T46N.

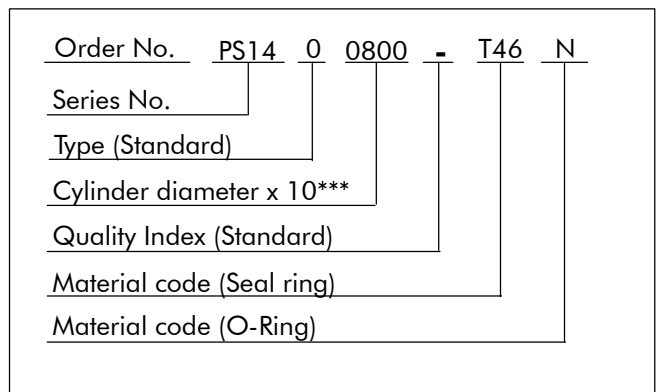



Table XXVIII Installation dimensions / Part No.

Bore Dia.	Groove Dia.	Groove Width	Part No.	O-Ring Dimensions
D _N H9	d ₁ h9	L ₁ +0.2		
9.0	4.1	2.2	PS1400090	3.68 x 1.78
10.0	5.1	2.2	PS1400100	4.80 x 1.8
12.0	7.1	2.2	PS1400120	6.70 x 1.8
14.0	9.1	2.2	PS1400140	8.75 x 1.8
15.0	10.1	2.2	PS1400150	9.25 x 1.78
16.0	11.1	2.2	PS1400160	10.82 x 1.78
18.0	10.7	3.2	PS1400180	9.19 x 2.62
20.0	15.1	2.2	PS1600200	14.00 x 1.78
20.0	12.7	3.2	PS1400200	12.37 x 2.62
22.0	14.7	3.2	PS1400220	13.94 x 2.62
25.0	17.7	3.2	PS1400250	17.12 x 2.62
25.0	14.3	4.2	PS1200250	13.87 x 3.53
28.0	17.3	4.2	PS1400280	15.47 x 3.53
30.0	22.7	3.2	PS1600300	21.89 x 2.62
30.0	19.3	4.2	PS1400300	18.66 x 3.53
32.0	24.7	3.2	PS1600320	23.47 x 2.62
32.0	21.3	4.2	PS1400320	20.22 x 3.53
35.0	24.3	4.2	PS1400350	23.40 x 3.53
40.0	32.7	3.2	PS1600400	31.42 x 2.62
40.0	29.3	4.2	PS1400400	28.17 x 3.53
42.0	31.3	4.2	PS1400420	29.75 x 3.53
45.0	34.3	4.2	PS1400450	32.92 x 3.53
48.0	37.3	4.2	PS1400480	36.09 x 3.53
50.0	39.3	4.2	PS1400500	37.70 x 3.53
50.0	34.9	6.3	PS1200500	32.69 x 5.33
52.0	41.3	4.2	PS1400520	40.87 x 3.53
55.0	44.3	4.2	PS1400550	44.04 x 3.53
60.0	44.9	6.3	PS1400600	43.82 x 5.33
63.0	52.3	4.2	PS1600630	50.39 x 3.53
63.0	47.9	6.3	PS1400630	46.99 x 5.33
65.0	49.9	6.3	PS1400650	46.99 x 5.33
70.0	59.3	4.2	PS1600700	56.74 x 3.53
70.0	54.9	6.3	PS1400700	53.34 x 5.33
75.0	59.9	6.3	PS1400750	56.52 x 5.33
80.0	64.9	6.3	PS1400800	62.87 x 5.33
80.0	59.5	8.1	PS1200800	58 x 7.0
85.0	69.9	6.3	PS1400850	69.22 x 5.33
85.0	64.5	8.1	PS1200850	63 x 7.0
90.0	74.9	6.3	PS1400900	72.39 x 5.33
90.0	69.5	8.1	PS1200900	68 x 7.0
95.0	79.9	6.3	PS1400950	78.74 x 5.33
95.0	74.5	8.1	PS1200950	73 x 7.0

Bore Dia.	Groove Dia.	Groove Width	Part No.	O-Ring Dimensions
D _N H9	d ₁ h9	L ₁ +0.2		
100.0	84.9	6.3	PS1401000	81.92 x 5.33
100.0	79.5	8.1	PS1201000	78 x 7.0
105.0	89.9	6.3	PS1401050	88.27 x 5.33
105.0	84.5	8.1	PS1201050	83 x 7.0
106.0	90.9	6.3	PS1401060	88.27 x 5.33
110.0	94.9	6.3	PS1401100	91.44 x 5.33
110.0	89.5	8.1	PS1201100	88 x 7.0
115.0	99.9	6.3	PS1401150	97.79 x 5.33
115.0	94.5	8.1	PS1201150	93 x 7.0
120.0	104.9	6.3	PS1401200	104.14 x 5.33
120.0	99.5	8.1	PS1201200	98 x 7.0
125.0	109.9	6.3	PS1401250	107.32 x 5.33
125.0	104.5	8.1	PS1201250	103 x 7.0
130.0	114.9	6.3	PS1401300	113.67 x 5.33
130.0	109.5	8.1	PS1201300	108.00 x 7.0
135.0	114.5	8.1	PS1201350	113.67 x 7.0
140.0	119.5	8.1	PS1201400	116.84 x 7.0
145.0	124.5	8.1	PS1201450	123.19 x 7.0
150.0	129.5	8.1	PS1201500	126.37 x 7.0
155.0	139.9	6.3	PS1401550	135.89 x 5.33
160.0	144.9	6.3	PS1401600	142.24 x 5.33
160.0	139.5	8.1	PS1201600	135.89 x 7.00
165.0	149.9	6.3	PS1401650	148.49 x 5.33
165.0	144.5	8.1	PS1201650	142.24 x 7.0
170.0	149.5	8.1	PS1201700	145.42 x 7.0
175.0	159.9	6.3	PS1401750	158.12 x 5.33
180.0	164.9	6.3	PS1401800	164.47 x 5.33
180.0	159.5	8.1	PS1201800	158.12 x 7.0
190.0	174.9	6.3	PS1401900	170.82 x 5.33
190.0	169.5	8.1	PS1201900	164.47 x 7.0
200.0	184.9	6.3	PS1602000	183.52 x 5.33
200.0	179.5	8.1	PS1402000	177.17 x 7.0
205.0	184.5	8.1	PS1402050	183.52 x 7.0
210.0	189.5	8.1	PS1402100	183.52 x 7.0
220.0	204.9	6.3	PS1602200	202.57 x 5.33
220.0	199.5	8.1	PS1402200	196.22 x 7.0
230.0	209.5	8.1	PS1402300	208.92 x 7.0
240.0	219.5	8.1	PS1402400	215.27 x 7.0
250.0	229.5	8.1	PS1402500	227.97 x 7.0
250.0	226.0	8.1	PS1202500	227.97 x 7.0
260.0	236.0	8.1	PS1402600	227.97 x 7.0
270.0	246.0	8.1	PS1402700	240.67 x 7.0



Bore Dia.	Groove Dia.	Groove Width	Part No.	O-Ring Dimensions
D _N H9	d ₁ h9	L ₁ +0.2		
280.0	256.0	8.1	PS1402800	253.37 x 7.0
300.0	276.0	8.1	PS1403000	266.07 x 7.0
306.0	285.5	8.1	PS1603060	278.77 x 7.0
310.0	286.0	8.1	PS1403100	278.77 x 7.0
320.0	299.5	8.1	PS1603200	291.47 x 7.0
320.0	296.0	8.1	PS1403200	291.47 x 7.0
330.0	306.0	8.1	PS1403300	304.17 x 7.0
340.0	316.0	8.1	PS1403400	316.87 x 7.0
345.0	324.5	8.1	PS1603450	316.87 x 7.0
350.0	326.0	8.1	PS1403500	316.87 x 7.0
360.0	336.0	8.1	PS1403600	329.57 x 7.0
370.0	346.0	8.1	PS1403700	342.27 x 7.0
380.0	356.0	8.1	PS1403800	354.97 x 7.0
400.0	376.0	8.1	PS1404000	367.67 x 7.0
420.0	396.0	8.1	PS1404200	393.07 x 7.0
430.0	406.0	8.1	PS1404300	405.26 x 7.0
440.0	416.0	8.1	PS1404400	405.26 x 7.0
450.0	426.0	8.1	PS1404500	417.96 x 7.0
480.0	456.0	8.1	PS1404800	456.06 x 7.0
500.0	476.0	8.1	PS1405000	468.76 x 7.0
520.0	499.5	8.1	PS1605200	494.16 x 7.0
540.0	516.0	8.1	PS1405400	506.86 x 7.0
600.0	576.0	8.1	PS1406000	557.66 x 7.0
650.0	626.0	8.1	PS1406500	608.08 x 7.0
700.0	672.7	9.5	PS1407000	670 x 8.4
800.0	772.7	9.5	PS1408000	770 x 8.4
860.0	832.7	9.5	PS1408600	830 x 8.4
900.0	872.7	9.5	PS1409000	870 x 8.4
920.0	892.7	9.5	PS1409200	890 x 8.4
1000.0	972.7	9.5	PS16X1000	970 x 8.4
1000.0	962.0	13.8	PS14X1000	960 x 12.0
1200.0	1172.7	9.5	PS16X1200	1170 x 8.4
1200.0	1162.0	13.8	PS14X1200	1160 x 12.0
1500.0	1462.0	13.8	PS14X1500	1460 x 12.0
2000.0	1962.0	13.8	PS14X2000	1960 x 12.0
2700.0	2662.0	13.8	PS14X2700	2660 x 12.0

The bore diameters in bold type comply with the recommendations of ISO 3320.

Other dimensions and all intermediate sizes up to 2.700 mm diameter including imperial (inch) sizes can be supplied.

All O-Rings with 12 mm cross section are delivered as special profiling.

TURCON[®] DOUBLE DELTA[®]

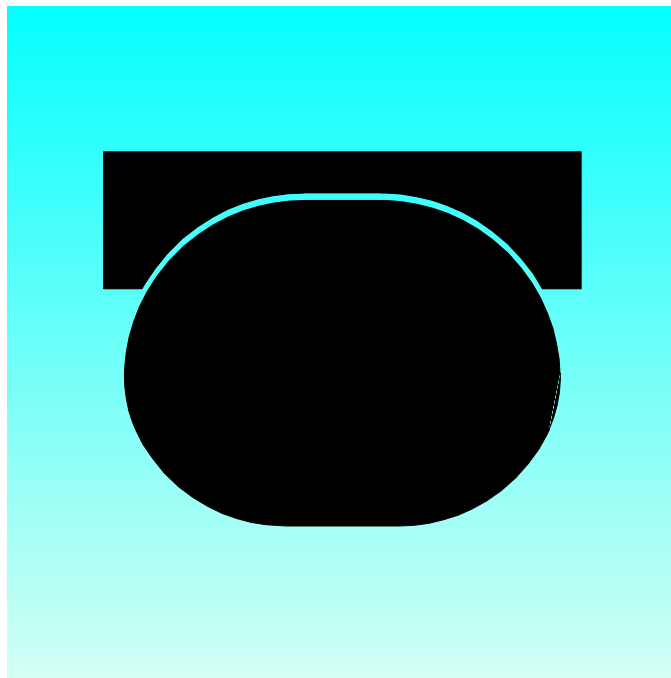

- Double Acting -
- Rubber Energised Plastic Faced Seal -
- For O-Ring Grooves -

- Material -
- Turcon[®] and Elastomer -





Turcon® Double Delta®

Description

Turcon® Double Delta® is a rubber energised plastic faced seal. The seal is designed to expand and improve the service parameters of O-Rings and is installed in existing O-Ring grooves.

Double Delta® combines the flexibility and response of O-Rings with the wear and friction characteristics of the Turcon® materials in dynamic applications.

The fig. below shows the cross section of the Double Delta®.

The double acting performance of the seal follows from the symmetrical cross section which allow the seal to respond to pressure in both directions.

Initial contact pressure is provided by radial compression of the O-Ring. When the system pressure is increased the O-Ring transforms this into additional contact pressure, the contact pressure of the seal is thereby automatically adjusted so sealing is ensured under all service conditions.

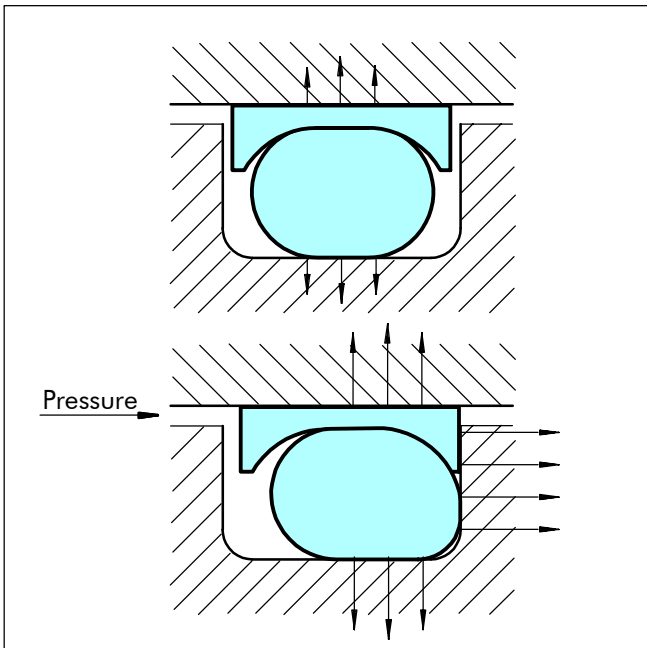

Figure 26 Turcon® Double Delta® without and with pressure

Notches

Turcon® Double Delta® is as standard supplied without radial notches, as the thin radial section of the seal gives good response to pressure variations.

For diameters from 8 mm notches on both sides are optional. These ensure direct pressurizing of the seal under all operating conditions.

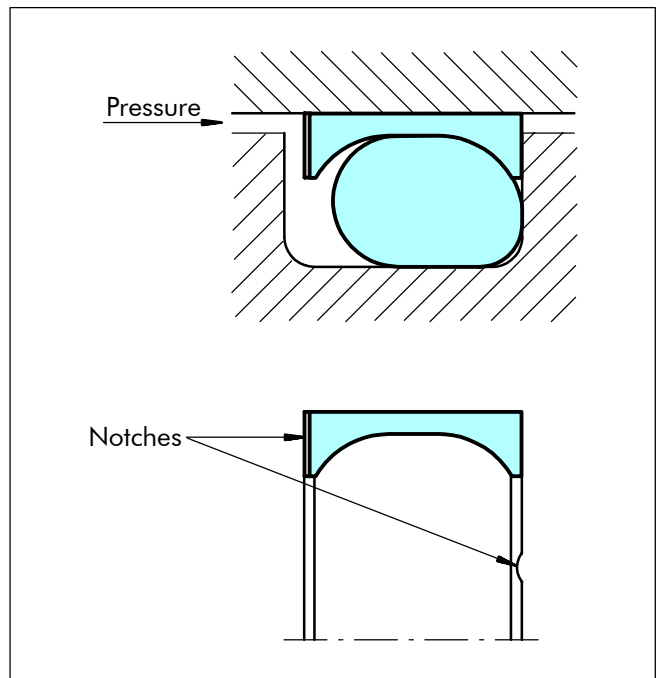

Figure 27 Turcon® Double Delta® with notches

Advantages

- Compact groove dimensions and simple installation
- Low friction without stick-slip
- Resistance against wear and extrusion
- Piston seals available for all diameters from 5 to 999.9 mm
- Standard cross sections cover AS 568A and important metric O-Rings, other cross sections available on request.
- Fits also groove dimensions per MIL-G-5514F

Application Examples

The Turcon® Double Delta® is the recommended sealing element for double acting pistons of hydraulic or pneumatic cylinders in sectors such as:

- Machine tools
- Handling devices
- Manipulators
- Valves
- Chemical process equipment

It is particular recommended for light duty and small diameter applications.



Technical Data

Operating conditions

Pressure:	Up to 35 MPa
Velocity:	Up to 15 m/s
Temperature:	-45°C to +200°C (according to O-Ring material)
Media:	Mineral oil, Non-flammable fluids, Environmentally safe fluids and others according to O-Ring material.

Important Note:

The above data are maximum values and cannot be used at the same time. e.g. the maximum operating speed depends on material type, pressure, temperature and gap value. Temperature range also dependent on medium.

Materials

Standard Application:

- For hydraulic components with reciprocating movement in mineral oils containing zinc or medium with good lubricating performance and hard mating surface.

Turcon® Seal: Turcon® T46

Energiser: O-Ring NBR 70 Shore A or FKM 70 Shore A depending on the temperature

Special Application:

- Short stroke movements, poor lubricating fluids and soft mating surfaces.

Turcon® seal: Turcon® T24

Energiser: O-Ring NBR 70 shore A or FKM 70 shore A (depending on the temp.)

- For low friction requirement in dynamic hydraulic components with good lubricating medium:

Turcon® seal: Turcon® T05

Energiser: O-Ring NBR 70 shore A or FKM 70 shore A (depending on the temp.)

- For specific applications other material combinations as listed may also be used. Please contact your local Busak+Shamban Company.

Material for the seal set:

Example:	T05 plus FKM - O-Ring	T05V
	T46 plus NBR - O-Ring	T46N

Design Instructions

Lead-in Chamfers

In order to avoid damage to the seal during installation, lead-in chamfers and rounded edges must be provided on the bore or piston rod (Figure 28).

The minimum lead-in chamfer depends on the profile size of the seal and can be seen from the following tables.

Table XXIX Lead-in Chamfers

Lead-in Chamfer* Diameter increase ΔD_N min.	O-Ring Cross Section** d_2
1.4	1.78 - 2.00
1.8	2.40 - 2.62
2.4	3.00 - 4.00
3.2	5.00 - 5.70
4.0	7.00 - 8.40

* Though not less than 1.5 % of bore diameter (bore/rod diameter).

**The O-Ring cross section d_2 can be found in the appropriate tables "Installation Dimensions", XXXI, XXXIII and XXXIV.

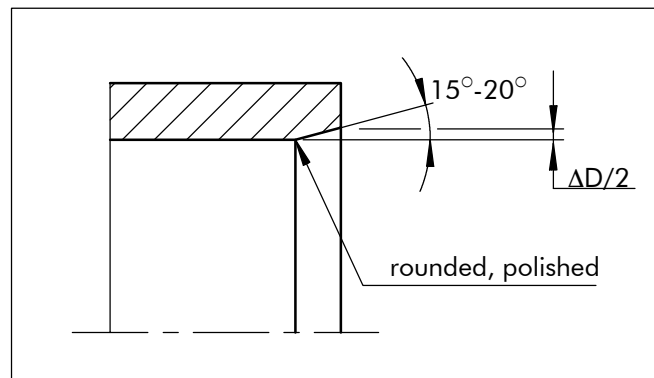

Figure 28 Lead-in chamfers



Materials

Table XXX Turcon® Materials for Double Delta®

Material, Applications, Properties	Code	O-Ring Material	Code	O-Ring Operating Temp.* °C	Mating Surface Material	MPa max.
Turcon® T46 Standard material for hydraulics, high compressive strength, good sliding and wear properties, good extrusion resistance, BAM tested. Bronze filled Colour: Greyish to dark brown	T46	NBR - 70 Shore A	N	-30 to +100	Steel tubes Steel, hardened Cast iron	35
		NBR - Low temp. 70 Shore A	T	-45 to +80		
		FKM - 70 Shore A	V	-10 to +200		
Turcon® T24 For all lubricating and non-lubricating hydraulic fluids, soft mating surfaces. Carbon filled Colour: Black	T24	NBR - 70 Shore A	N	-30 to +100	Steel Steel, hardened Cast iron Stainless steel Aluminium Bronze	25
		NBR - Low temp. 70 Shore A	T	-45 to +80		
		FMK - 70 Shore A	V	-10 to +200		
		EPDM - 70 Shore A	E**	-45 to +145		
Turcon® T05 For all lubricating hydraulic fluids, hard mating surfaces, very good sliding properties, low friction. Colour: Turquoise	T05	NBR - 70 Shore A	N	-30 to +100	Steel tubes Steel, hardened	20
		NBR - Low temp. 70 Shore A	T	-45 to +80		
		FKM - 70 Shore A	V	-10 to +200		

* The O-Ring Operation Temperature is only valid in mineral hydraulic oil. BAM: Tested by "Bundes Anstalt Materialprüfung, Germany".

Highlighted materials are standard. **Material not suitable for mineral oils.



Installation Recommendation

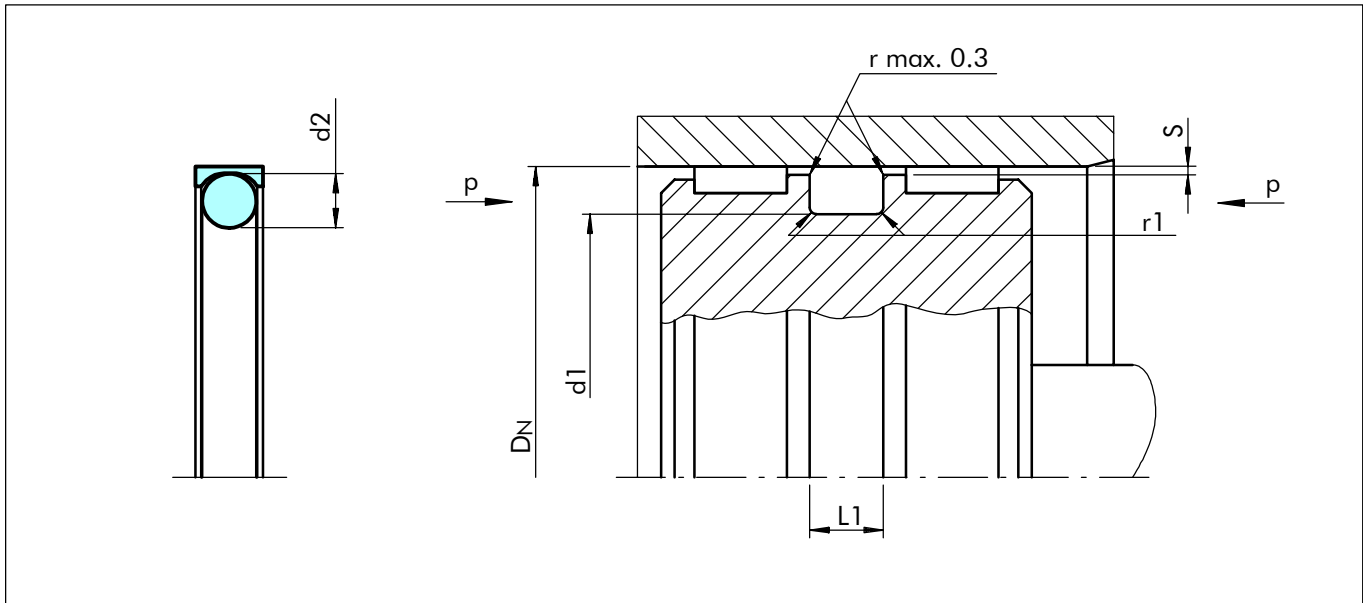

Figure 29 Installation drawing

Table XXXI Installation Dimensions

Series No.	Bore Diameter D_N H9		Groove Diameter d_1 h9	Groove Width $L_1 +0.2$	Radius r_1	Radial Clearance S max				O-Ring Cross-Sec. d_2
	Standard Range	Extended Range				2 MPa	10 MPa	20 MPa	35 MPa	
PDD0	5 - 13.9	5 - 139.9	$D_N-2.9$	2.4	0.4	0.10	0.10	0.08	0.05	1.78
PDD1	14 - 24.9	8 - 259.9	$D_N-4.5$	3.6	0.4	0.15	0.15	0.10	0.07	2.62
PDD2	25 - 45.9	12 - 469.9	$D_N-6.2$	4.8	0.6	0.25	0.20	0.15	0.08	3.53
PDD3	46 - 124.9	20 - 669.9	$D_N-9.4$	7.1	0.8	0.35	0.25	0.20	0.10	5.33
PDD4	125 - 669.9	80 - 999.9	$D_N-12.2$	9.5	0.8	0.50	0.30	0.25	0.15	7.00
PDD5	670 - 999.9	125 - 999.9	$D_N-15.0$	10.0	1.0	0.60	0.40	0.30	0.20	8.40

Ordering example

Turcon® Double Delta®, complete with O-Ring, standard range, series PDD3 (from Table XXXI).

Bore diameter: $D_N = 80.0$ mm

Part No.: PDD300800 (from Table XXXII)

Select the material from Table XXX. The corresponding code numbers are appended to the Part No. (from Table XXXII). Together they form the Order No.

For all intermediate sizes not shown in Table XXXII, the Order No. can be determined from the example opposite.

* "N" for seals with notches. Available for diameters from 8.0 mm.

For seals for other groove widths/Dimensions please refer to table XXXIII and XXXIV.

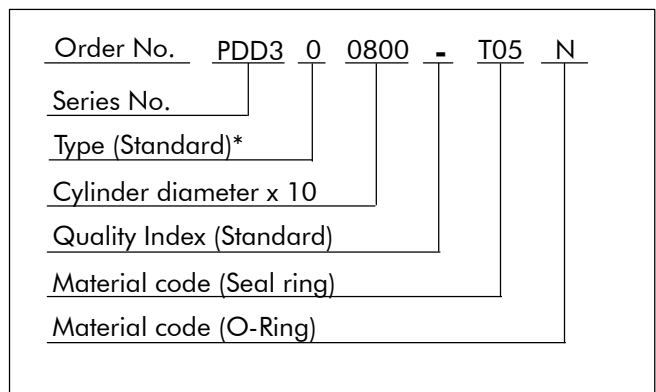



Table XXXII Installation dimensions/Part No.

Bore Diameter	Groove Diameter	Groove Width	Part No.	O-Ring Sizes
D _N H9	d ₁ h9	L ₁ +0.2		
6.0	3.1	2.4	PDD000060	2.57 x 1.78
8.0	5.1	2.4	PDD000080	4.47 x 1.78
9.0	6.1	2.4	PDD000090	5.28 x 1.78
10.0	7.1	2.4	PDD000100	6.07 x 1.78
11.0	8.1	2.4	PDD000110	7.65 x 1.78
12.0	9.1	2.4	PDD000120	8.5 x 1.8
12.7	9.8	2.4	PDD000127	9.25 x 1.78
14.0	9.5	3.6	PDD100140	9.19 x 2.62
15.0	10.5	3.6	PDD100150	9.19 x 2.62
16.0	11.5	3.6	PDD100160	10.77 x 2.62
18.0	13.5	3.6	PDD100180	12.37 x 2.62
20.0	15.5	3.6	PDD100200	13.94 x 2.62
22.0	17.5	3.6	PDD100220	17.12 x 2.62
24.0	19.5	3.6	PDD100240	18.72 x 2.62
25.0	18.8	4.8	PDD200250	18 x 3.55
25.4	19.2	4.8	PDD200254	18.54 x 3.53
27.0	20.8	4.8	PDD200270	20.22 x 3.53
28.0	21.8	4.8	PDD200280	20.22 x 3.53
30.0	23.8	4.8	PDD200300	23.40 x 3.53
32.0	25.8	4.8	PDD200320	25.00 x 3.53
35.0	28.8	4.8	PDD200350	28.17 x 3.53
40.0	33.8	4.8	PDD200400	32.92 x 3.53
42.0	35.8	4.8	PDD200420	34.52 x 3.53
45.0	38.8	4.8	PDD200450	37.70 x 3.53
48.0	38.6	7.1	PDD300480	37.47 x 5.33
50.0	40.6	7.1	PDD300500	40.0 x 5.30
50.8	41.4	7.1	PDD300508	40.64 x 5.33
52.0	42.6	7.1	PDD300520	40.64 x 5.33
55.0	45.6	7.1	PDD300550	43.82 x 5.33
56.0	46.6	7.1	PDD300560	43.82 x 5.33
60.0	50.6	7.1	PDD300600	50.17 x 5.33
63.0	53.6	7.1	PDD300630	53.34 x 5.33
65.0	55.6	7.1	PDD300650	53.34 x 5.33
70.0	60.6	7.1	PDD300700	59.69 x 5.33
75.0	65.6	7.1	PDD300750	62.87 x 5.33
80.0	70.6	7.1	PDD300800	69.22 x 5.33
85.0	75.6	7.1	PDD300850	72.39 x 5.33
90.0	80.6	7.1	PDD300900	78.74 x 5.33
95.0	85.6	7.1	PDD300950	81.92 x 5.33

Bore Diameter	Groove Diameter	Groove Width	Part No.	O-Ring Sizes
D _N H9	d ₁ h9	L ₁ +0.2		
100.0	90.6	7.1	PDD301000	88.27 x 5.33
110.0	100.6	7.1	PDD301100	97.79 x 5.33
115.0	105.6	7.1	PDD301150	104.14 x 5.33
120.0	110.6	7.1	PDD301200	107.32 x 5.33
125.0	112.8	9.5	PDD401250	113.67 x 7.0
130.0	117.8	9.5	PDD401300	116.84 x 7.0
135.0	122.8	9.5	PDD401350	120.02 x 7.0
140.0	127.8	9.5	PDD401400	126.37 x 7.0
150.0	137.8	9.5	PDD401500	135.89 x 7.0
160.0	147.8	9.5	PDD401600	145.42 x 7.0
170.0	157.8	9.5	PDD401700	151.77 x 7.0
180.0	167.8	9.5	PDD401800	164.47 x 7.0
190.0	177.8	9.5	PDD401900	177.17 x 7.0
200.0	187.8	9.5	PDD402000	183.52 x 7.0
210.0	197.8	9.5	PDD402100	196.22 x 7.0
220.0	207.8	9.5	PDD402200	202.57 x 7.0
230.0	217.8	9.5	PDD402300	215.27 x 7.0
240.0	227.8	9.5	PDD402400	227.97 x 7.0
250.0	237.8	9.5	PDD402500	236.0 x 7.0
280.0	267.8	9.5	PDD402800	266.07 x 7.0
300.0	287.8	9.5	PDD403000	278.77 x 7.0
320.0	307.8	9.5	PDD403200	304.17 x 7.0
350.0	337.8	9.5	PDD403500	329.57 x 7.0
400.0	387.8	9.5	PDD404000	380.37 x 7.0
420.0	407.8	9.5	PDD404200	405.26 x 7.0
450.0	437.8	9.5	PDD404500	430.66 x 7.0
480.0	467.8	9.5	PDD404800	456.06 x 7.0
500.0	487.8	9.5	PDD405000	481.46 x 7.0

The bore diameters in bold type comply with the recommendations of ISO 3320.

Part No. for other dimensions and **all** intermediate dimensions up to 999.9 mm diameter including imperial (inch) dimensions can be supplied. Larger dimensions up to 2700 mm available upon request.



Special Turcon® Double Delta®

Turcon® Double Delta® for one Back-up Ring grooves

Double Delta® is available for designs where grooves for O-Ring with one Back up Ring are used according to Table XXXIII.

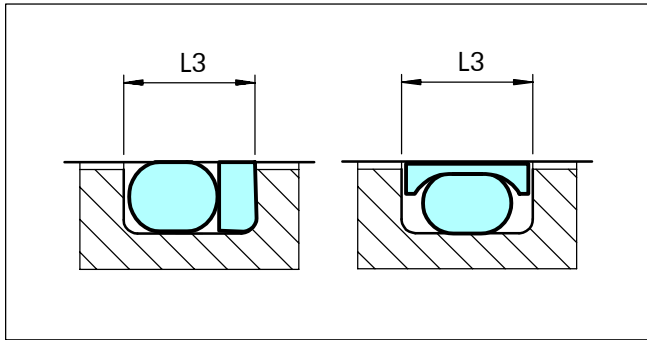

Figure 30 Groove width

Table XXXIII Seals for one Back-up Ring groove

Series No.	Groove Width	Execution Mark 5th digit		O-Ring Cross Section
	L ₃	Without Notch	With Notch*	d ₂
PDA0	3.80	0	N	1.78
PDA1	4.65	0	N	2.62
PDA2	5.70	0	N	3.53
PDA3	8.50	0	N	5.33
PDA4	11.20	0	N	7.00
PDA5	12.50	0	N	8.40

* Available for diameters from 8 mm

Turcon® Double Delta® for metric O-Rings

Double Delta® is available for installation in grooves for metric O-Rings as listed in Table XXXIV.

Table XXXIV Seals for Metric O-Ring Grooves

O-Ring Cross-Section	Groove Diameter	Groove Width	Series No.	Execution Mark 5th digit		Available Range
				Standard	Notch*	
d ₂	d ₁ h ₉	L ₁ +0.2				
2.0	D _N - 3.3	2.7	PD2A	0	N	6 - 100.0
2.4	D _N - 4.1	3.2	PD2E	0	N	8 - 160.0
2.5	D _N - 4.3	3.3	PD2F	0	N	8 - 160.0
3.0	D _N - 5.2	4.0	PD3A	0	N	12 - 200.0
4.0	D _N - 7.0	5.2	PD4A	0	N	16 - 300.0
5.0	D _N - 8.8	6.6	PD5A	0	N	20 - 400.0
5.7	D _N - 10.0	7.2	PD5H	0	N	20 - 669.9

* Available for diameters from 8 mm

Ordering example

Double Delta® complete with NBR O-Ring

Bore diameter: D_N = 80 mm

Groove diameter: 70.6 mm

Groove width: 8.5 mm.

Order No.: PDA300800-T05N

Order No.	PDA3	0	0800	-	T05	N
Series No.*						
Type (Standard) ¹⁾						
Cylinder diameter x 10						
Quality Index (Standard)						
Material code (Seal ring)**						
Material code (O-Ring)***						

* From table XXXIII or XXXIV
 ** From table XXX
 *** From table XXX
¹⁾ N for seals with notches, available from dia. 8mm

TURCON[®] VARISEAL[®] M2

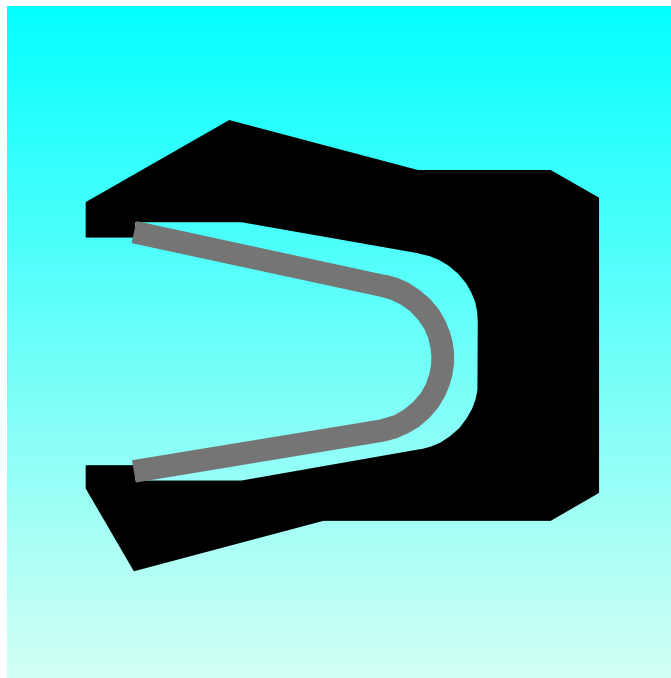

- Single Acting -

- Spring Energised Plastic U-Cup -

- Material -

- Turcon[®] and Zurcon[®] -





Turcon® Variseal® M2

Description

The Turcon® Variseal® M2 is a single-acting seal consisting of a U-shaped seal jacket and a V-shaped corrosion resistant spring.

The characteristic of the Variseal® M2 is the newly developed asymmetric seal profile, where the dynamic lip has an optimized short and heavy profile, offering reduced friction and long service life.

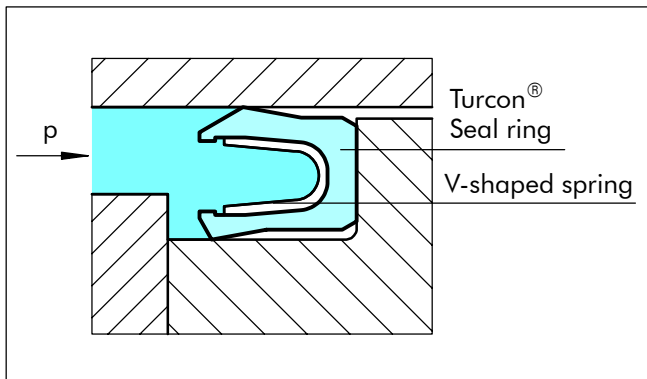

Figure 31 Turcon® Variseal® M2

At low and zero pressure, the metal spring provides the primary sealing force. As the system pressure increases, the main sealing force is achieved by the system pressure and ensures a tight seal from zero to high pressure.

The possibility of matching suitable materials for the seal and the spring allows use in a wide range of applications going beyond the field of hydraulics, e.g. in the chemical, pharmaceutical and foodstuffs industry.

The Variseal® M2 can be sterilized and is available in a special Hi-Clean version where the spring cavity is filled with a Silicone gel preventing contaminants from being entrapped in the seal. This design also works well in applications involving mud, slurries or adhesives to keep grit from packing into the seal cavity and inhibiting the spring action.

For applications with highly viscous media, please contact our Technical department.

Variseal® M2 seals can be installed in grooves to MIL G 5514F and ISO 3771. The seal can only be installed to a limited extent in closed grooves. Installation instructions, see Table VII.

Advantages

- Resistant to most fluids and chemicals
- Low coefficients of friction
- Stick-slip free operating for precise control
- High abrasion resistance and dimensional stability
- Can handle rapid changes in temperature
- No contamination in contact with foodstuffs, pharmaceutical and medicinal fluids
- Sterilisable
- Unlimited shelf life

Application Examples

The Turcon® Variseal® M2 is the recommended sealing element for all applications requiring stick-slip free operation as well as chemical resistance against almost all media such as:

- Valves
- Pumps
- Separators
- Actuators
- Dosing devices

It requires a mating surface of high quality to avoid high wear rates.

Technical Data

Operating conditions	
pressure:	For dynamic loads: 45 MPa
Speed:	Up to 15 m/s
Temperature:	-70° C to +260° C
	For specific applications at lower temperatures, please enquire
Media:	Practically all fluids, chemicals and gases

Important Note:

The above data are maximum values and cannot be used at the same time. e.g. the maximum operating speed depends on material type, pressure, temperature and gap value. Temperature range also dependent on medium.



Materials

All materials used are physiologically safe. They contain no odour or taste-affecting substances.

The following material combination has proved effective for most fluid applications:

Seal ring: Turcon® T 40
Spring: Stainless steel, Material No. AISI 301
Material code S

For gas applications use:

Seal ring: T05 or Z80

For use in accordance with the demands of the "Food and Drug Administration", suitable materials are available on request.

Table XXXV Turcon® and Zurcon® Materials for Variseal® M2

Material, Applications, Properties	Code	Spring Material	Code	Operating Temp.* °C	Mating Surface Material	MPa max.
Turcon® T40 For all lubricating and non-lubricating hydraulic fluids, water hydraulic, soft mating surfaces. Carbon fibre filled Colour: Grey	T40	AISI 301	S	-70 to +260	Steel Cast iron Stainless steel Aluminium Bronze Alloys	45
Turcon® T05 For all lubricating hydraulic fluids, hard mating surfaces, very good sliding properties, low friction. Colour: Turquoise	T05	AISI 301	S	-70 to +260	Steel tubes Steel, hardened	20
Zurcon® Z80 For lubricating and non-lubricating hydraulic fluids, high abrasion resistance, very good chemical resistance, limited temperature resistance. FDA compliance. Ultra high molecular weight polyethylen Colour: White to off-white	Z80	AISI 301	S	-70 to +80	Steel Stainless steel Aluminium Bronze Ceramic coating	40

* Depending on media.

Highlighted materials are standard.

Installation of Spring Energised Seals

See page 13



■ Installation Recommendation

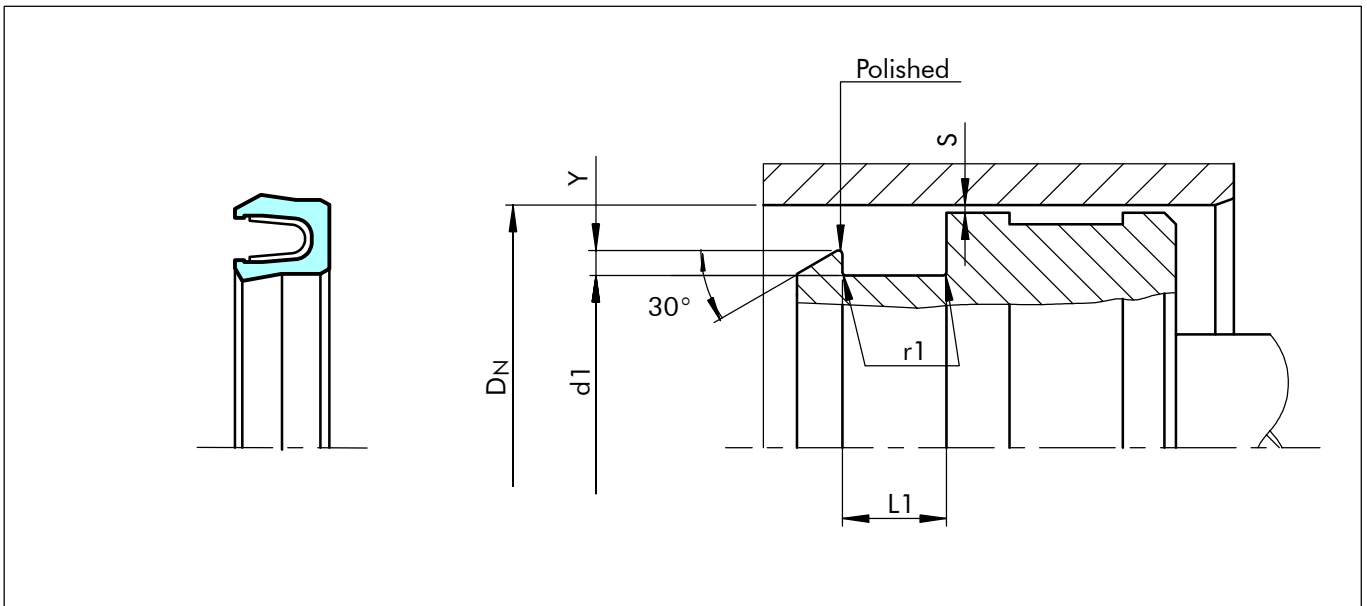

Figure 32 Installation drawing

Table XXXVI Installation Dimensions

Series No.	Bore Diameter D _N H9		Groove Diameter d ₁ h9	Groove Width L ₁ +0.2	Radius r ₁	Step2) Height Y min.	Radial Clearance S max*			
	Standard Range	Extended ¹⁾ Range					<2 MPa	<10 MPa	<20 MPa	<40 MPa
PVA0	6.0 - 13.9	6.0 - 40.0	D _N -2.9	2.4	0.4	0.4	0.20	0.10	0.08	0.05
PVA1	14.0 - 24.9	10.0 - 200.0	D _N -4.5	3.6	0.4	0.6	0.25	0.15	0.10	0.07
PVA2	25.0 - 45.9	16.0 - 400.0	D _N -6.2	4.8	0.6	0.7	0.35	0.20	0.15	0.08
PVA3	46.0 - 124.9	28.0 - 700.0	D _N -9.4	7.1	0.8	0.8	0.50	0.25	0.20	0.10
PVA4	125.0 - 999.9	45.0 - 999.9	D _N -12.2	9.5	0.8	0.9	0.60	0.30	0.25	0.12
PVA5	1000.0 - 2700.0	100.0 - 2500.0	D _N -19.0	15.0	0.8	0.9	0.90	0.50	0.40	0.20

*At pressures > 40 MPa use diameter tolerance H8/f8 (bore/piston) in area of the seal.

¹⁾ Available on request.

²⁾ Y_{max} = 0.035 x D_N

Ordering example

Turcon® Variseal® M2, standard range, Series PVA3 (from Table XXXVI).

Bore diameter: D_N = 80.0 mm

Part No.: PVA300800 (from Table XXXVII)

Select the material from Table XXXV. The corresponding code numbers are appended to the Part No. (from Table XXXVII). Together they form the Order No.

For all intermediate sizes not shown in Table XXXVII, the Order No. can be determined from the example opposite.

** For diameters ≥ 1000.0 mm multiply only by factor 1.

Example: PVA5 for diameter 1200.0 mm.

Order no.: PVA5X1200 - T40S.

Order No.	PVA3	0	0800	-	T40	S
Series No.						
Type (Standard)						
Cylinder diameter x 10**						
Quality Index (Standard)						
Material code (Seal ring)						
Material code (Spring)						



Table XXXVII Installation dimensions / Part No.

Bore Diameter	Groove Diameter	Groove Width	Part No.
$D_N H9$	$d_1 h9$	$L_1 +0.2$	
6.0	3.1	2.4	PVA000060
8.0	5.1	2.4	PVA000080
10.0	7.1	2.4	PVA000100
12.0	9.1	2.4	PVA000120
14.0	9.5	3.6	PVA100140
15.0	10.5	3.6	PVA100150
16.0	11.5	3.6	PVA100160
18.0	13.5	3.6	PVA100180
20.0	15.5	3.6	PVA100200
22.0	17.5	3.6	PVA100220
25.0	18.8	4.8	PVA200250
28.0	21.8	4.8	PVA200280
30.0	23.8	4.8	PVA200300
32.0	25.8	4.8	PVA200320
35.0	28.8	4.8	PVA200350
40.0	33.8	4.8	PVA200400
42.0	35.8	4.8	PVA200420
45.0	38.8	4.8	PVA200450
48.0	38.6	7.1	PVA300480
50.0	40.6	7.1	PVA300500
52.0	42.6	7.1	PVA300520
55.0	45.6	7.1	PVA300550
56.0	46.6	7.1	PVA300560
60.0	50.6	7.1	PVA300600
63.0	53.6	7.1	PVA300630
65.0	55.6	7.1	PVA300650
70.0	60.6	7.1	PVA300700
75.0	65.6	7.1	PVA300750
80.0	70.6	7.1	PVA300800
85.0	75.6	7.1	PVA300850
90.0	80.6	7.1	PVA300900
95.0	85.6	7.1	PVA300950
100.0	90.6	7.1	PVA301000
110.0	100.6	7.1	PVA301100
115.0	105.6	7.1	PVA301150
120.0	110.6	7.1	PVA301200
125.0	112.8	9.5	PVA401250
130.0	117.8	9.5	PVA401300
135.0	122.8	9.5	PVA401350

Bore Diameter	Groove Diameter	Groove Width	Part No.
$D_N H9$	$d_1 h9$	$L_1 +0.2$	
140.0	127.8	9.5	PVA401400
150.0	137.8	9.5	PVA401500
160.0	147.8	9.5	PVA401600
170.0	157.8	9.5	PVA401700
180.0	167.8	9.5	PVA401800
190.0	177.8	9.5	PVA401900
200.0	187.8	9.5	PVA402000
210.0	197.8	9.5	PVA402100
220.0	207.8	9.5	PVA402200
230.0	217.8	9.5	PVA402300
240.0	227.8	9.5	PVA402400
250.0	237.8	9.5	PVA402500
280.0	267.8	9.5	PVA402800
300.0	287.8	9.5	PVA403000
320.0	307.8	9.5	PVA403200
350.0	337.8	9.5	PVA403500
400.0	387.8	9.5	PVA404000
420.0	407.8	9.5	PVA404200
450.0	437.8	9.5	PVA404500
480.0	467.8	9.5	PVA404800
500.0	487.8	9.5	PVA405000

The bore diameters in bold type comply with the recommendations of ISO 3320.

Other dimensions and all intermediate sizes up to 2.700 mm diameter including imperial (inch) sizes can be supplied.

ZURCON[®] U-CUP PUA

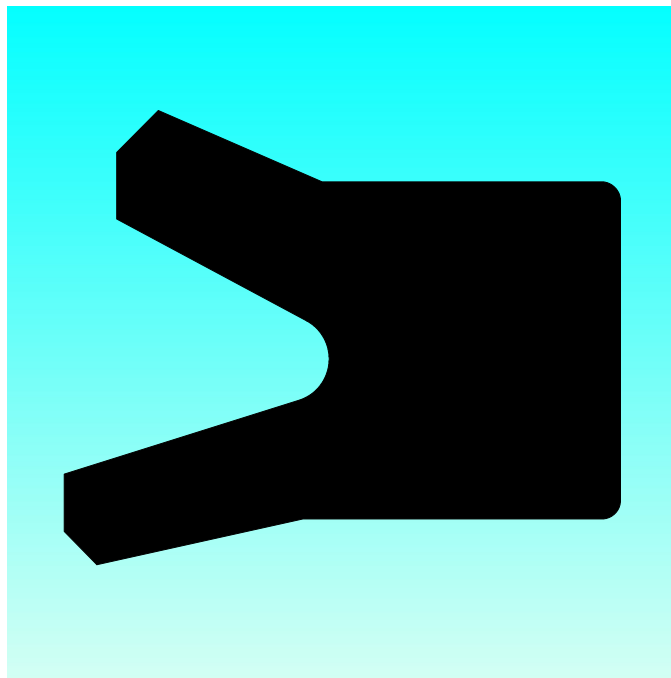

- Single Acting -

- Asymmetric, Single Lip -

- Material -

- Zurcon[®] Polyurethane -





■ Piston U-Cup PUA

Description

The U-Cup is a single acting piston seal out of injection moulded polyurethane. It is provided with a robust dynamic sealing lip and a wide contact area of the static lip, which guaranties an effective positioning in the groove.

The profile is suitable for pressures up to 40 MPa provided that the extrusion gap is adapted to the pressure level.

Thanks to the elasticity of the polyurethane material the U Cup can easily be installed in closed grooves.

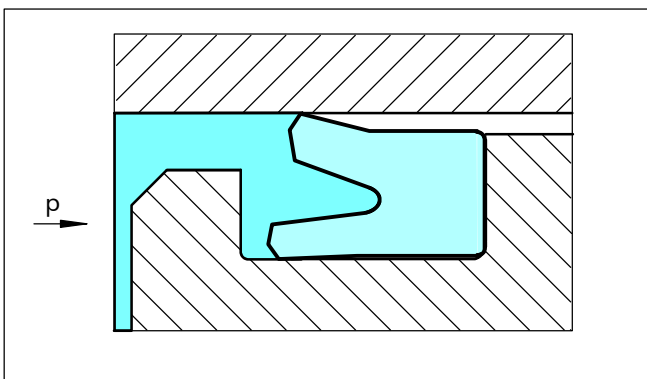

Figure 33 Piston U-Cup Type PUA

Advantages

- Simple groove design
- High abrasion resistance
- Long service life
- Effective sealing effect even with non excellent mating surface finish

Application Examples

The U-Cup is the recommended sealing element for single acting pistons of hydraulic components such as:

- Presses
- Lift platforms
- Aftermarket

Technical Data

Operating conditions

Pressure: Up to 40 MPa

Speed: Up to 0.5 m/s

Temperature: from -35°C to + 110°C

Media: Mineral oil based hydraulic fluids

Clearance: From table XXXVIII the maximum of the radial clearance S_{max} can be selected for dimensioning the piston. The values indicated in this table must be reduced by 30% when temperature exceeds 80°C.

Table XXXVIII Clearance

Operating Pressure MPa	Radial Clearance S_{max} .	
	$d_N < 60$ mm	$d_N > 60$ mm
5	0.40	0.50
10	0.30	0.40
20	0.20	0.30
30	0.15	0.20
40	0.10	0.15

Important Note:

The above data are maximum values and cannot be used at the same time. e.g. the maximum operating speed depends on material type, pressure, temperature and gap value. Temperature range also dependent on medium.

Materials

Standard Material:

- For hydraulic components in mineral oils or medium with good lubricating performance, polyurethane 93 Shore A

Zurcon® Z20

Colour: turquoise



Zurcon[®] U-Cup PUA

Ordering Example

Bore diameter: $D_N = 80$ mm
Groove diameter: $d1 = 65$ mm
Groove width: $L1 = 13$ mm
Part number: PUA100800 (Table XXXIX)
Material code: Z20

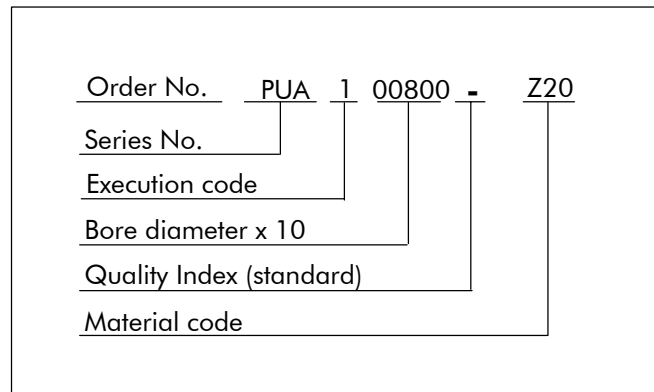



■ Installation Recommendation

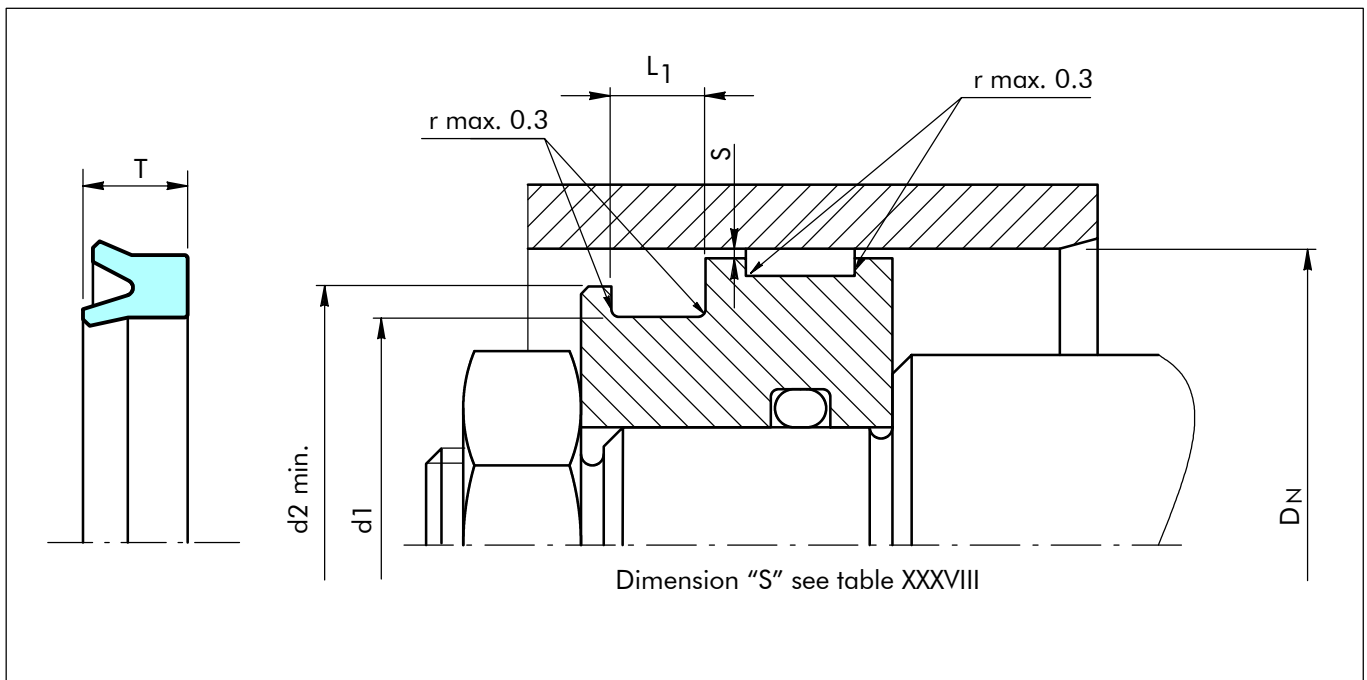

Figure 34 Installation drawing

Table XXXIX Installation dimensions / Part No.

Bore Dia.	Groove Dia.	Seal Width	Groove Width	Fitting Dia.	Part No.	B+S	Sealing Parts Ref. No.
D_N H9	$d1$ h9	T	$L1$ +0.2	$d2$ min			
12.0	5.0	5.5	6.0	8.0	PUA000120		RSE 12 5
14.0	8.0	6.3	6.8	11.0	PUA000140		RSE 14 8
16.0	10.0	6.0	6.5	13.0	PUA100160	*	RSE 16 10/1
16.0	10.0	8.0	9.0	13.0	PUA200160	*	RSE 16 10
20.0	12.0	6.5	7.5	15.0	PUA000200	*	RSE 20 12
20.0	14.0	5.5	6.0	17.0	PUA100200	*	RSE 20 14
22.0	12.0	8.0	9.0	16.0	PUA000220	*	RSE 22 12
25.0	10.0	10.0	11.0	14.0	PUA100250	*	RSE 25 10
25.0	15.0	8.0	9.0	19.0	PUA000250	*	RSE 25 15
30.0	15.0	9.5	10.5	19.0	PUA300300	*	-
30.0	15.0	10.0	11.0	19.0	PUA000300		RSE 30 15
30.0	20.0	8.0	9.0	24.0	PUA100300	*	RSE 30 20
30.0	22.0	6.5	7.0	26.0	PUA400300	*	RSE 30 22
32.0	22.0	8.0	9.0	26.0	PUA000320	*	RSE 32 22/1
32.0	22.0	10.0	11.0	26.0	PUA100320	*	RSE 32 22
32.0	26.0	5.0	6.0	28.0	PUA200320	*	RSE 32 26
34.0	22.0	8.4	9.4	26.0	PUA100340		RSE 34 22/1
34.0	22.0	9.0	10.0	26.0	PUA200340		RSE 34 22
34.0	28.0	3.5	4.0	31.0	PUA000340	*	-
35.0	20.0	10.0	11.0	25.0	PUA000350	*	RSE 35 20
35.0	25.0	8.0	9.0	29.0	PUA100350	*	RSE 35 25

* B+S mold available, same ref. as Part No.



Zurcon® U-Cup PUA

Bore Dia.	Groove Dia.	Seal Width	Groove Width	Fitting Dia.	Part No.	B+S	Sealing Parts Ref. No.
D _N H9	d1 h9	T	L1 +0.2	d2 min			
35.0	27.0	10.0	11.0	31.0	PUA200350	*	RSE 35 27
36.5	24.0	6.2	7.0	28.0	PUA000365		RSE 36.5 24
37.0	21.0	12.0	13.0	25.0	PUA000370	*	RSE 37 21
38.0	31.0	4.7	5.2	34.0	PUA000380	*	RSE 38 31
40.0	25.0	10.0	11.0	30.0	PUA000400	*	RSE 40 25
40.0	30.0	6.5	7.5	34.0	PUA200400		RSE 40 30/1
40.0	30.0	10.0	11.0	34.0	PUA500400	*	RSE 40 30
40.0	32.0	5.5	6.5	36.0	PUA300400	*	-
40.0	32.0	8.0	9.0	36.0	PUA100400	*	RSE 40 32
40.0	33.0	8.0	9.0	36.0	PUA400400	*	RSE 40 33
42.0	32.0	10.0	11.0	36.0	PUA000420		RSE 42 32
42.0	34.5	4.2	4.7	38.0	PUA100420		RSE 42 34.5
43.0	25.0	9.0	10.0	29.0	PUA000430		RSE 43 25
44.0	20.0	11.0	12.0	25.0	PUA000440	*	RSE 44 20
44.0	25.0	11.0	12.0	30.0	PUA100440	*	-
45.0	28.5	12.0	13.0	33.0	PUA000450		RSE 45.28.5
45.0	30.0	10.0	11.0	35.0	PUA100450	*	RSE 45 30
50.0	30.0	12.0	13.0	35.0	PUA500500		RSE 50 30
50.0	32.0	10.0	11.0	37.0	PUA600500		RSE 50 32
50.0	35.0	8.5	9.5	40.0	PUA100500	*	RSE 50 35/1
50.0	35.0	10.0	11.0	40.0	PUA200500	*	RSE 50 35
50.0	40.0	5.0	5.5	44.0	PUA000500		RSE 50 40/1
50.0	40.0	8.0	9.0	44.0	PUA800500	*	-
50.0	40.0	10.0	11.0	44.0	PUA400500	*	RSE 50 40
50.0	42.0	5.5	6.0	45.0	PUA900500	*	RSE 50 42/2
50.0	42.0	8.0	9.0	45.0	PUA700500		RSE 50 42/1
50.0	42.0	10.0	11.0	45.0	PUA300500	*	RSE 50 42
50.8	40.8	7.0	8.0	45.0	PUA100508		RSE 50.8 40.8
52.0	42.0	5.7	6.5	46.0	PUA000520	*	-
52.0	42.0	10.0	10.6	46.0	PUA100520		RSE 52 42
55.0	40.0	10.0	11.0	45.0	PUA000550	*	RSE 55 40
55.0	45.0	10.0	11.0	48.0	PUA100550	*	-
55.0	47.0	5.7	6.3	50.0	PUA200550		RSE 55 47
60.0	40.0	10.0	11.0	45.0	PUA200600	*	-
60.0	40.0	12.0	13.0	45.0	PUA100600	*	RSE 60 40
60.0	40.0	13.5	14.5	45.0	PUA400600		RSE 60 40/1
60.0	45.0	10.0	11.0	50.0	PUA500600		RSE 60 45
60.0	50.0	5.0	5.5	54.0	PUA300600		RSE 60 50/1
60.0	50.0	7.0	8.0	54.0	PUA000600		RSE 60 50
60.0	50.0	10.0	11.0	54.0	PUA600600		RSE 60 50/2
60.0	52.0	8.0	9.0	55.0	PUA700600		RSE 60 52
63.0	43.0	12.0	13.0	47.0	PUA800630		RSE 63 43
63.0	45.0	10.0	11.0	50.0	PUA700630		RSE 63 45
63.0	45.0	12.0	13.0	50.0	PUA600630	*	-
63.0	48.0	8.5	9.5	53.0	PUA400630	*	-

* B+S mold available, same ref. as Part No.



Bore Dia.	Groove Dia.	Seal Width	Groove Width	Fitting Dia.	Part No.	B+S	Sealing Parts Ref. No.
D _N H9	d1 h9	T	L1 +0.2	d2 min			
63.0	48.0	10.0	11.0	53.0	PUA300630		RSE 63 48/1
63.0	48.0	12.0	13.0	53.0	PUA000630	*	RSE 63 48
63.0	53.0	6.3	7.0	57.0	PUA500630	*	-
63.0	53.0	7.0	8.0	57.0	PUA200630	*	RSE 63 53
63.0	53.0	12.0	13.0	57.0	PUA100630		RSE 63 53/1
65.0	45.0	12.0	13.0	50.0	PUA000650	*	RSE 65 45/1
65.0	45.0	13.5	14.5	50.0	PUA300650		RSE 65 45
65.0	50.0	10.0	11.0	55.0	PUA100650	*	RSE 65 50
65.0	50.0	11.5	12.5	55.0	PUA200650	*	RSE 65 50/1
65.0	55.0	10.0	11.0	59.0	PUA400650		RSE 65 55/1
65.0	55.0	13.5	14.5	59.0	PUA500650		RSE 65 55
68.0	48.0	10.0	11.0	53.0	PUA000680		RSE 68 48
70.0	50.0	12.0	13.0	55.0	PUA000700	*	RSE 70 50
70.0	50.0	13.5	14.5	55.0	PUA200700		RSE 70 50/1
70.0	50.0	15.0	16.0	55.0	PUA500700		RSE 70 50/2
70.0	55.0	9.5	10.5	60.0	PUA600700		RSE 70 55/1
70.0	55.0	12.0	13.0	60.0	PUA400700	*	RSE 70 55
70.0	60.0	7.0	8.0	64.0	PUA100700	*	RSE 70 60
70.0	60.0	12.0	13.0	64.0	PUA700700		RSE 70 60/1
70.0	60.0	13.5	14.5	64.0	PUA800700		RSE 70 60/2
70.0	62.0	7.5	8.5	65.0	PUA300700		RSE 70 62
72.0	58.0	12.0	13.0	62.0	PUA000720		RSE 72 58
75.0	50.0	14.0	15.0	55.0	PUA000750		RSE 75 50
75.0	55.0	13.5	14.5	60.0	PUA100750	*	RSE 75 55
75.0	65.0	5.0	5.5	69.0	PUA200750		RSE 75 65/1
75.0	65.0	6.7	7.5	69.0	PUA300750		RSE 75 65/3
75.0	65.0	10.0	11.0	69.0	PUA400750		RSE 75 65/2
75.0	65.0	7.0	8.0	69.0	PUA500750		RSE 75 65/4
75.0	65.0	13.5	14.5	69.0	PUA600750		RSE 75 65
76.0	56.0	12.0	13.0	61.0	PUA000760	*	-
80.0	60.0	10.0	11.0	65.0	PUA400800	*	-
80.0	60.0	11.5	12.5	65.0	PUA500800	*	-
80.0	60.0	12.0	13.0	65.0	PUA000800	*	RSE 80 60
80.0	60.0	13.5	14.5	65.0	PUA200800		RSE 80 60/1
80.0	65.0	12.0	13.0	70.0	PUA100800	*	RSE 80 65
80.0	68.0	8.5	9.5	72.0	PUA300800	*	-
80.0	70.0	12.0	13.0	74.0	PUA700800		RSE 80 70/1
80.0	70.0	7.0	8.0	74.0	PUA600800		RSE 80 70
80.0	72.0	12.0	13.0	75.0	PUA800800		RSE 80 72
85.0	65.0	12.0	13.0	70.0	PUA100850	*	-
85.0	65.0	13.5	14.5	70.0	PUA200850	*	RSE 85 65
85.0	70.0	12.0	13.0	75.0	PUA300850	*	-
85.0	75.0	10.0	11.0	79.0	PUA400850		RSE 85 75/1
85.0	75.0	12.0	13.0	79.0	PUA000850		RSE 85 75
90.0	70.0	12.0	13.0	75.0	PUA100900	*	RSE 90 70

* B+S mold available, same ref. as Part No.



Zurcon[®] U-Cup PUA

Bore Dia.	Groove Dia.	Seal Width	Groove Width	Fitting Dia.	Part No.	B+S	Sealing Parts Ref. No.
D _N H9	d1 h9	T	L1 +0.2	d2 min			
90,0	70,0	13,5	14,5	75,0	PUA200900		RSE 90 70/1
90,0	75,0	12,0	13,0	80,0	PUA300900	*	RSE 90 75
90,0	80,0	5,0	5,5	84,0	PUA500900		RSE 90 80/2
90,0	80,0	10,0	11,0	84,0	PUA000900		RSE 90 80/1
90,0	80,0	13,0	14,0	84,0	PUA400900		RSE 90 80
95,0	75,0	13,5	14,5	80,0	PUA100950		RSE 95 75
95,0	80,0	12,0	13,0	85,0	PUA000950	*	-
95,0	85,0	6,7	7,5	89,0	PUA200950		RSE 95 85/2
95,0	85,0	7,0	8,0	89,0	PUA300950		RSE 95 85
95,0	85,0	8,5	9,5	89,0	PUA400950		RSE 95 85/1
95,0	85,0	13,5	14,5	89,0	PUA500950		RSE 95 85/3
100,0	80,0	10,0	11,0	85,0	PUA501000		RSE 100 80/2
100,0	80,0	11,5	12,5	85,0	PUA201000	*	-
100,0	80,0	12,0	13,0	85,0	PUA001000		RSE 100 80
100,0	80,0	13,5	14,5	85,0	PUA601000		RSE 100 80/1
100,0	85,0	8,5	9,5	90,0	PUA301000	*	-
100,0	85,0	12,0	13,0	90,0	PUA401000	*	RSE 100 85
100,0	86,0	12,0	13,0	90,0	PUA701000		RSE 100 86
100,0	88,0	8,5	9,5	93,0	PUA101000	*	-
100,0	90,0	7,0	8,0	94,0	PUA801000		RSE 100 90
100,0	90,0	10,5	11,5	94,0	PUA901000		RSE 100 90/1
101,6	80,0	12,0	13,0	85,0	PUA001016		RSE 101.6 80
105,0	90,0	12,0	13,0	95,0	PUA001050	*	RSE 105 90
110,0	90,0	12,0	13,0	95,0	PUA001100		RSE 110 90
110,0	95,0	12,0	13,0	100,0	PUA101100	*	RSE 110 95
110,0	100,0	7,0	8,0	104,0	PUA201100		RSE 110 100
110,0	100,0	13,5	14,5	104,0	PUA301100		RSE 110 100/1
115,0	100,0	10,5	11,5	105,0	PUA101150		RSE 115 100
115,0	100,0	12,0	13,0	105,0	PUA001150	*	-
115,0	105,0	13,5	14,5	109,0	PUA201150		RSE 115 105
120,0	95,0	12,0	13,0	100,0	PUA401200		RSE 120 95
120,0	100,0	12,0	13,0	105,0	PUA001200	*	RSE 120 100
120,0	100,0	13,5	14,5	105,0	PUA101200		RSE 120 100/1
120,0	103,0	16,0	17,0	108,0	PUA501200		RSE 120 103
120,0	105,0	12,0	13,0	110,0	PUA301200	*	-
125,0	100,0	15,0	16,0	105,0	PUA201250	*	-
125,0	105,0	12,0	13,0	110,0	PUA301250	*	RSE 125 105
125,0	105,0	15,0	16,0	110,0	PUA001250	*	RSE 125 105/1
125,0	110,0	10,0	11,0	115,0	PUA101250	*	-
125,0	110,0	12,0	13,0	115,0	PUA401250	*	-
125,0	115,0	7,0	8,0	119,0	PUA501250		RSE 125 115
125,0	115,0	15,0	16,0	119,0	PUA601250		RSE 125 115/1
130,0	110,0	15,0	16,0	115,0	PUA001300	*	-
140,0	120,0	12,0	13,0	125,0	PUA001400	*	-
150,0	130,0	15,0	16,0	135,0	PUA101500	*	-

* B+S mold available, same ref. as Part No.



Bore Dia.	Groove Dia.	Seal Width	Groove Width	Fitting Dia.	Part No.	B+S	Sealing Parts Ref. No.
D _N H9	d1 h9	T	L1 +0.2	d2 min			
160,0	140,0	11,5	12,5	145,0	PUA001600	*	-
165,0	145,0	15,0	16,0	150,0	PUA001650	*	-
180,0	160,0	11,5	12,5	165,0	PUA201800	*	-
200,0	170,0	19,0	20,0	175,0	PUA002000	*	-
200,0	175,0	15,0	16,0	180,0	PUA102000	*	-
250,0	220,0	19,0	20,0	225,0	PUA002500	*	-
250,0	225,0	15,0	16,0	230,0	PUA102500	*	-

* B+S mold available, same ref. as Part No.



Zurcon[®] U-Cup PUA

ZURCON[®] WYNSEAL

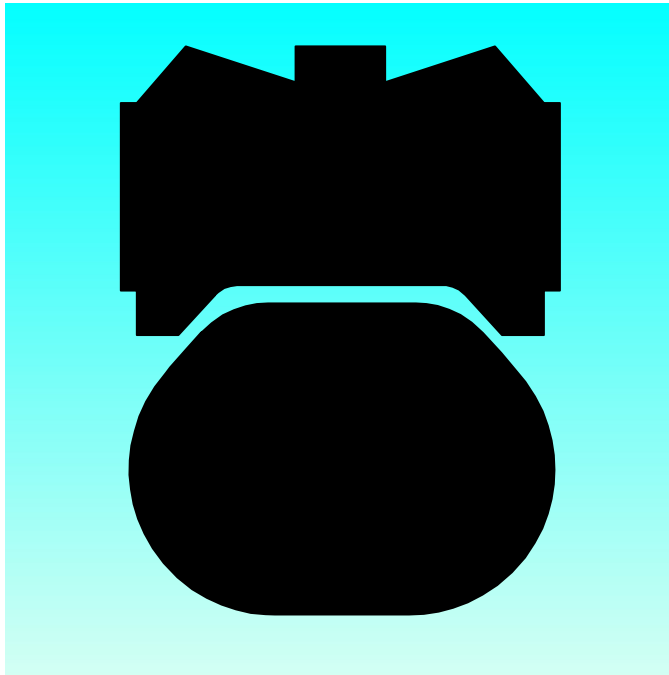

- Double Acting -
- Rubber Energised Plastic Face Seal -
- High Static and Dynamic Sealing Effect -

- Material -
- Zurcon[®] Polyurethane + NBR -





■ Zurcon® Wynseal

Description

The Zurcon® Wynseal is a double-acting seal consisting of a special polyurethane seal ring and an O-Ring as energizing element (Figure 35).

The particular characteristic of the seal is the special design of the seal edge profile. Two external seal edges act as primary seal for pressures from both sides and prevent any build-up of hydrodynamic pressure over the seal profile and the risk of the blow-by effect. The central back-up and sealing bulge increases the sealing effect*. Grooves are provided on both sides on the plane surfaces to provide activation of the energizing O-Ring. These ensure direct pressure loading of the seal under all operating conditions.

Since the installation groove is identical to that for the Turcon® Glyd Ring®, the seal is ideal for the standardisation of cylinder construction if, efficient and low cost seal elements are demanded in large quantities and, the cylinder can be adapted to meet different operating conditions. It has to be taken into consideration that in this case the gap dimension has to be checked !

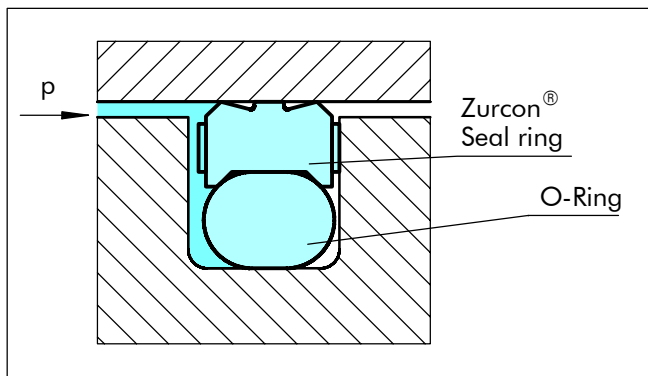

Figure 35 Zurcon® Wynseal

Advantages

- High static and dynamic sealing effect
- High abrasion resistance
- Simple groove design, one-piece piston possible
- Suitable for grooves to ISO 7425, Part 1.

*Only from PW42 and the following Series No.; PW40 and PW41 without sealing and supporting bulge.

Application Examples

The Zurcon® Wynseal is the recommended sealing element for double acting pistons of hydraulic components in various sectors such as:

- Machine tools
- Forklifts & handling machinery
- Agriculture
- Industrial hydraulic light to medium duty

Technical Data

pressure:	Up to 25 MPa	(Z20N)
	Up to 40 MPa	(Z05N/WUAGN)
Speed:	Up to 0.5 m/s	
Temperature:	-35°C to +110°C	
Media:	Mineral oil-based hydraulic fluids	

Important Note:

The above data are maximum values and cannot be used at the same time. e.g. the maximum operating speed depends on material type, pressure, temperature and gap value. Temperature range also dependent on medium.

Materials

Standard Materials:

■ B+S references:

Wynseal:	Zurcon® Z20, 93 Shore A (on request 96 Shore A: reference Z05)
O-Ring:	NBR 70 Shore A
Set reference:	Z20N/Z05N

■ Sealing Parts references:

Sealing ring:	Polyurethane 96 Shore A
O-Ring:	NBR 70 Shore A
Set reference:	WUAGN



Installation Recommendation

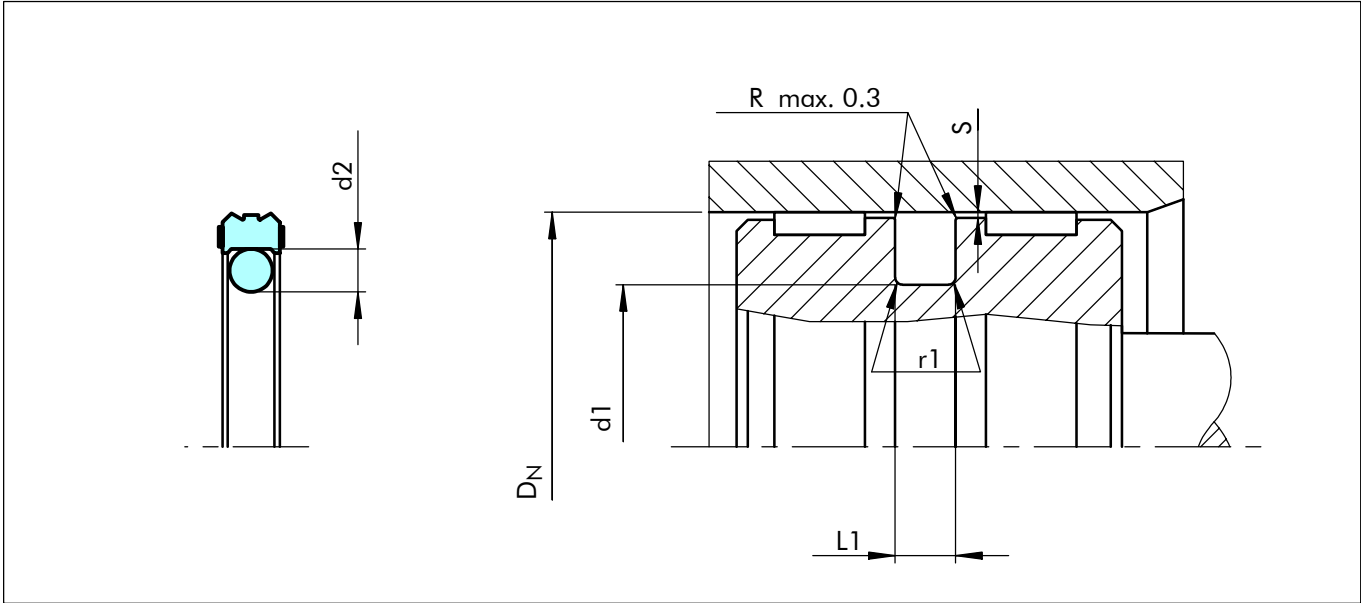

Figure 36 Installation drawing

Table XL Installation Dimensions

Series No.	Groove Diameter	Groove Width	Radius	Radial Clearance	O-Ring Cross Section
	d_1 h9	$L_1 +0.2$	r_1	S max	d_2
PW40	$D_N-4,9$	2,2	0,4	0,20	1,78
PW41	$D_N-7.5$	3.2	0.6	0.25	2.62
PW42	$D_N-11.0$	4.2	1.0	0.25	3.53
PW43	$D_N-15.5$	6.3	1.3	0.30	5.33
PW44	$D_N-21.0$	8.1	1.8	0.30	7.00

Ordering example

Wynseal for ISO groove

Cylinder diameter: $D_N = 63$ mm

Series No. PW43

Part No. PW4300630 (from Table XLI)

B+S seal ring

material code: Z20

O-Ring material code: N

Set code: Z20N

Sealing Parts seal ring

material code: WUAG

O-Ring material code: N

Set code: WUAGN

Order No.	PW43	0	0630	-	Z20	N
Series No.						
Type (Standard)						
Cylinder diameter x 10						
Quality Index (Standard)						
Material code (Seal ring)						
Material code (O-Ring)						

Order No.	PW43	0	0630	-	WUAG	N
Series No.						
Type (Standard)						
Cylinder diameter x 10						
Quality Index (Standard)						
Material code (Seal ring)						
Material code (O-Ring)						
Sealing Parts Ref. No.:	GPS 63 47.5 6.3					



Table XLI Installation dimensions / Part No.

Bore Diameter	Groove Diameter	Groove Width	Part No.	B+S	Sealing Parts
				Material code	
D _N H9	d ₁ h9	L1 +0.2		Z20N or Z05N	WUAGN
12.0	7.1	2.2	PW4000120	*	
12.0	4.5	3.2	PW4100120	*	
15.0	7.5	3.2	PW4100150	*	
16.0	8.5	3.2	PW4100160	*	GPS 16 8.5 3.2
20.0	12.5	3.2	PW4100200	*	GPS 20 12.5 3.2
22.0	14.5	3.2	PW4100220		GPS 22 14.5 3.2
24.0	16.5	3.2	PW4100240	*	
25.0	17.5	3.2	PW4100250	*	
25.0	14.0	4.2	PW4200250	*	GPS 25 14 4.2
28.0	20.5	3.2	PW4100280		GPS 28 20.5 3.2
30.0	22.5	3.2	PW4100300	*	GPS 30 22.5 3.2
32.0	24.5	3.2	PW4100320	*	GPS 32 24.5 3.2
32.0	21.0	4.2	PW4200320	*	GPS 32 21 4.2
34.0	26.5	3.2	PW4100340	*	
35.0	27.5	3.2	PW4100350	*	GPS 35 27.5 3.2
35.0	24.0	4.2	PW4200350	*	
36.0	28.5	3.2	PW4100360	*	
36.0	25.0	4.2	PW4200360	*	
38.0	30.5	3.2	PW4100380	*	
40.0	29.0	4.2	PW4200400	*	GPS 40 29 4.2
40.0	24.5	6.3	PW4300400	*	GPS 40 24.5 6.3
42.0	31.0	4.2	PW4200420	*	
45.0	29.5	6.3	PW4300450	*	GPS 45 29.5 6.3
45.0	34.0	4.2	PW4200450	*	GPS 45 34 4.2
48.0	37.0	4.2	PW4200480	*	
49.0	38.0	4.2	PW4200490		GPS 49 38 4.2
50.0	34.5	6.3	PW4300500	*	GPS 50 34.5 6.3
50.0	39.0	4.2	PW4200500	*	GPS 50 39 4.2
50.8	39.8	4.2	PW420B223	*	
52.0	36.5	6.3	PW4300520		GPS 52 36.5 6.3
54.0	43.0	4.2	PW4200540		GPS 54 43 4.2
55.0	44.0	4.2	PW4200550	*	GPS 55 44 4.2
55.0	39.5	6.3	PW4300550	*	GPS 55 39.5 6.3
56.0	45.0	4.2	PW4200560	*	
57.0	46.0	4.2	PW4200570	*	
60.0	44.5	6.3	PW4300600	*	GPS 60 44.5 6.3
60.0	49.0	4.2	PW4200600	*	GPS 60 49 4.2
63.0	52.0	4.2	PW4200630	*	GPS 63 52 4.2
63.0	47.5	6.3	PW4300630	*	GPS 63 47.5 6.3
63.5	52.5	4.2	PW420B227	*	
65.0	54.0	4.2	PW4200650	*	GPS 65 54 4.2
65.0	49.5	6.3	PW4300650	*	GPS 65 49.5 6.3
70.0	59.0	4.2	PW4200700	*	GPS 70 59 4.2
70.0	54.5	6.3	PW4300700	*	GPS 70 54.5 6.3
72.0	61.0	4.2	PW4200720		GPS 72 61 4.2

* B+S mold available, same ref. as Part No.

The sizes printed in **bold** type are suitable for grooves to ISO 7425/1.

The listed products are technically equivalent but availability and pricing may vary.

Imperial (inch) sizes can be supplied.



Bore Diameter	Groove Diameter	Groove Width	Part No.	B+S	Sealing Parts
				Material code	
D _N H9	d1 h9	L1 +0.2		Z20N or Z05N	WUAGN
74.0	58.5	6.3	PW4300740	*	
75.0	64.0	4.2	PW4200750	*	GPS 75 64 4.2
75.0	59.5	6.3	PW4300750	*	GPS 75 59.5 6.3
76.2	65.2	4.2	PW420B231	*	
80.0	69.0	4.2	PW4200800	*	GPS 80 69 4.2
80.0	64.5	6.3	PW4300800	*	GPS 80 64.5 6.3
82.55	67.05	6.3	PW430B335	*	
85.0	69.5	6.3	PW4300850	*	GPS 85 69.5 6.3
88.9	73.4	6.3	PW430B337	*	
90.0	74.5	6.3	PW4300900	*	GPS 90 74.5 6.3
95.0	79.5	6.3	PW4300950	*	
100.0	84.5	6.3	PW4301000	*	GPS 100 84.5 6.3
101.6	86.1	6.3	PW430B341	*	
105.0	89.5	6.3	PW4301050	*	GPS 105 89.5 6.3
110.0	94.5	6.3	PW4301100	*	GPS 110 94.5 6.3
115.0	99.5	6.3	PW4301150	*	
115.0	94.0	8.1	PW4401150	*	
118.0	102.5	6.3	PW4301180	*	
120.0	104.5	6.3	PW4301200	*	GPS 120 104.5 6.3
125.0	109.5	6.3	PW4301250	*	GPS 125 109.5 6.3
125.0	104.0	8.1	PW4401250	*	
127.0	111.5	6.3	PW430B349	*	
130.0	114.5	6.3	PW4301300	*	GPS 130 114.5 6.3
130.0	109.0	8.1	PW4401300	*	
135.0	119.5	6.3	PW4301350	*	
135.0	114.0	8.1	PW4401350	*	
140.0	119.0	8.1	PW4401400	*	GPS 140 119 8.1
145.0	124.0	8.1	PW4401450	*	
150.0	129.0	8.1	PW4401500	*	GPS 150 129 8.1
152.4	131.4	8.1	PW440B431	*	
160.0	139.0	8.1	PW4401600	*	GPS 160 139 8.1
170.0	149.0	8.1	PW4401700	*	GPS 170 149 8.1
177.8	156.8	8.1	PW440B438	*	
180.0	159.0	8.1	PW4401800	*	GPS 180 159 8.1
185.0	164.0	8.1	PW4401850	*	
190.0	169.0	8.1	PW4401900	*	
200.0	179.0	8.1	PW4402000	*	GPS 200 179 8.1
203.2	182.2	8.1	PW440B442	*	
210.0	189.0	8.1	PW4402100	*	
220.0	199.0	8.1	PW4402200	*	
230.0	209.0	8.1	PW4402300	*	
240.0	219.0	8.1	PW4402400	*	
250.0	229.0	8.1	PW4402500	*	GPS 250 229 8.1
300.0	279.0	8.1	PW4403000	*	

* B+S mold available, same ref. as Part No.

The sizes printed in **bold** type are suitable for grooves to ISO 7425/1.

The listed products are technically equivalent but availability and pricing may vary.

Imperial (inch) sizes can be supplied.

POLYPAC[®] PHD/P



- Double Acting -

- Heavy Duty, High Pressure -

- Excellent Leakage Control -

- Material -

- Zurcon[®] Polyurethane, NBR Elastomer + POM -





■ PHD/P Seal

Description

The PHD/P Seal is a high-pressure heavy-duty piston seal with excellent leakage control and superior extrusion and wear resistance

The PHD/P seal is a combination of a Zurcon® polyurethane slipper seal energised by an elastomer profile ring and completed with two Back-up rings (POM). It is manufactured with a predefined interference fit, which together with the squeeze of the elastomer part ensures a good sealing effect even at low system pressure. At higher pressures the elastomer part is energised by the system pressure and consequently activates the slipper seal in the radial direction.

The Back-up rings prevent the slipper seal from extrusion and ensure a long service life even under harsh conditions.

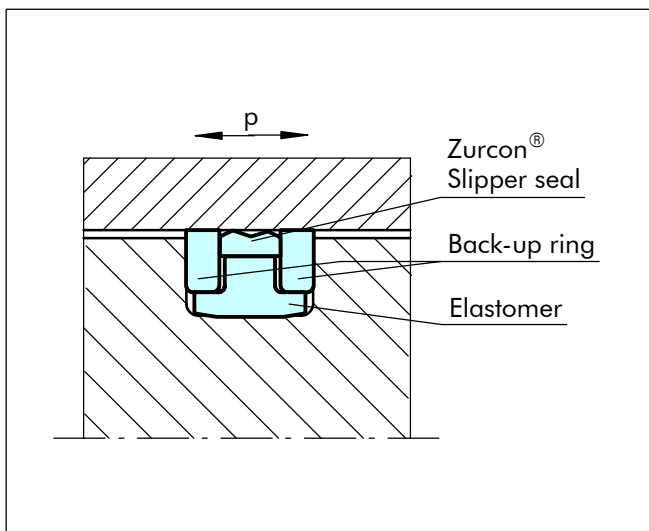

Figure 37 PHD/P Seal

Advantages

- Simple groove design
- Excellent sealing effect
- Excellent wear resistance
- Increased clearance possible
- Long service life

Application Examples

The PHD/P Seal is the recommended sealing element for double acting pistons of hydraulic cylinders working in very harsh conditions such as:

- Excavators
- Heavy duty cylinders

Technical Data

Operating conditions

pressure: Up to 40 MPa
Peak pressure up to 60 MPa

Speed: Up to 0.5 m/s

Temperature: -35°C to +110°C

Media: Mineral oil based hydraulic fluids

Clearance: The maximum permissible radial clearance S_{max} is shown in Table XLII, as a function of the operating pressure and functional diameter.

Important Note:

The above data are maximum values and cannot be used at the same time. e.g. the maximum operating speed depends on material type, pressure, temperature and gap value. Temperature range also dependent on medium.

Materials

Standard Application:

For hydraulic components in mineral oils or medium with good lubricating performance.

Slipper Seal: Zurcon® Z20 93 Shore A

Energiser: NBR 80 Shore A

Back-up rings: POM

Material code for the set: Z2053



■ Installation Recommendation

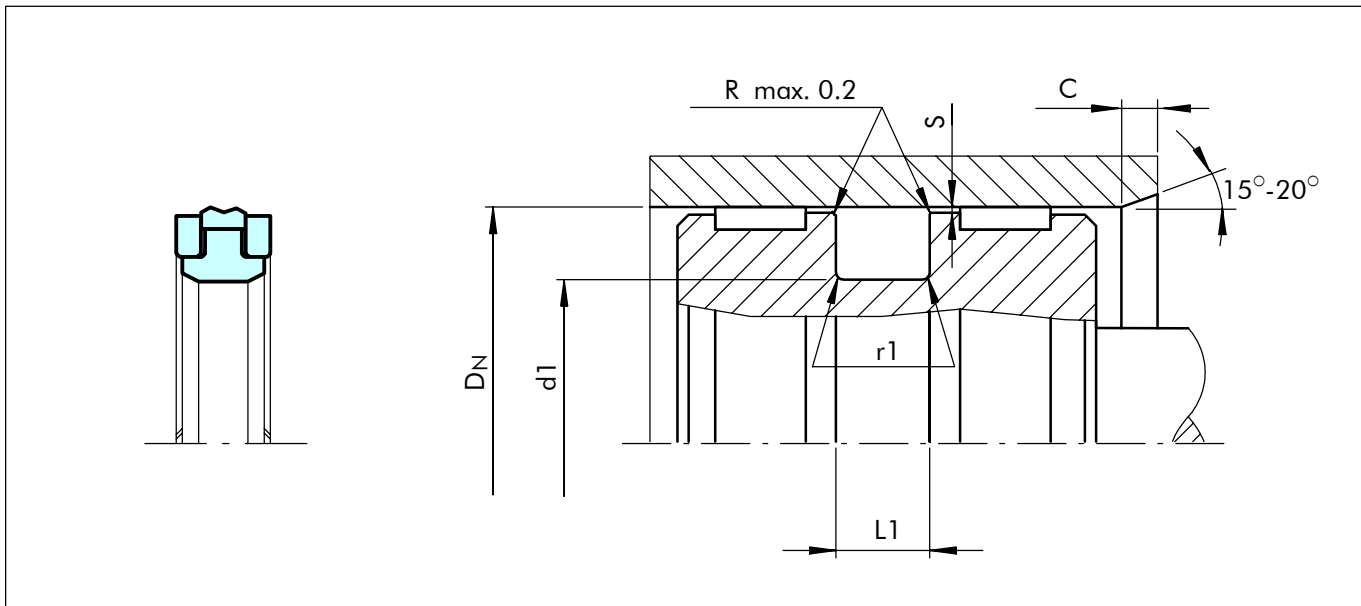

Figure 38 Installation drawing

Table XLII Installation dimensions / Part No.

Bore Dia.	Groove Dia.	Groove Width	Inlet Chamfer	Radius	Radial Clearance	Part No	Polypac Ref. No.
D_N H9	$d1$ h9	$L1$ +0.2	C	$r1$	S		
50.0	36.0	9.0	5.0	0.3		PKPOP0500	PHD 5036P
55.0	41.0	9.0	5.0	0.3		PKPOP0550	PHD 5541P
60.0	46.0	9.0	5.0	0.3		PKPOP0600	PHD 6046P
63.0	48.0	11.0	5.0	0.5	For pressure up to 35 MPa 0.50	PKPOP0630	PHD 6348P
65.0	50.0	11.0	5.0	0.5		PKPOP0650	PHD 6550P
70.0	55.0	11.0	5.0	0.5		PKPOP0700	PHD 7055P
75.0	60.0	11.0	5.0	0.5	For pressure from 35 MPa up to 60 MPa 0.30	PKPOP0750	PHD 7560P
80.0	65.0	11.0	5.0	0.5		PKPOP0800	PHD 8065P
85.0	70.0	11.0	5.0	0.5		PKPOP0850	PHD 8570P
90.0	75.0	11.0	5.0	0.5		PKPOP0900	PHD 9075P
95.0	80.0	12.5	5.0	0.5		PKPOP0950	PHD 9580P
100.0	85.0	12.5	5.0	0.5		PKPOP1000	PHD 10085P
105.0	90.0	12.5	5.0	0.5		PKPOP1050	PHD 10590P
110.0	95.0	12.5	5.0	0.5		PKPOP1100	PHD 11095P
115.0	100.0	12.5	5.0	0.5		PKPOP1150	PHD 115100P
120.0	105.0	12.5	5.0	0.5		PKPOP1200	PHD 120105P
125.0	102.0	16.0	6.5	0.6		PKPOP1250	PHD 125102P
130.0	107.0	16.0	6.5	0.6		PKPOP1300	PHD 130107P



Bore Dia.	Groove Dia.	Groove Width	Inlet Chamfer	Radius	Radial Clearance	Part No	Polypac Ref. No
D_N H9	$d1$ h9	L1 +0.2	C	r1	S		
135.0	112.0	16.0	6.5	0.6	For pressure up to 35 MPa 0.50	PKPOP1350	PHD 135112P
140.0	117.0	16.0	6.5	0.6		PKPOP1400	PHD 140117P
145.0	122.0	16.0	6.5	0.6		PKPOP1450	PHD 145122P
150.0	127.0	16.0	6.5	0.6	For pressure from 35 MPa up to 60 MPa 0.30	PKPOP1500	PHD 150127P
155.0	132.0	16.0	6.5	0.6		PKPOP1550	PHD 155132P
160.0	137.0	16.0	6.5	0.6		PKPOP1600	PHD 160137P
165.0	142.0	16.0	6.5	0.6		PKPOP1650	PHD 165142P
170.0	147.0	16.0	6.5	0.6		PKPOP1700	PHD 170147P
180.0	157.0	16.0	6.5	0.6		PKPOP1800	PHD 180157P

Ordering Example

PHD/P Seal, complete.

Bore diameter: $D_N = 80.0$ mm

Part No. PKPOP0800 (from Table XLII)

Material set-code: Z2053

Polypac Ref. No.: PHD 8065P

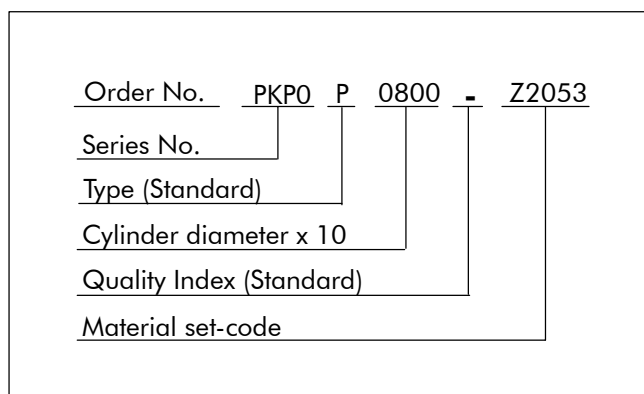



**COMPACT SEAL
D A S TYPE A/B
POLYPAC[®] DBM**

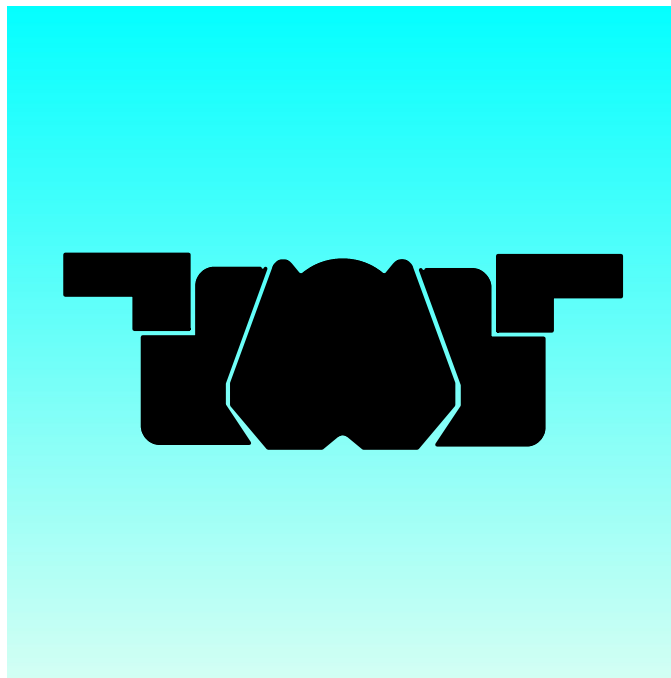

- Double Acting -
- Combined Seal and Guide Element -
- Material -
- NBR, Polyester Elastomer + POM -





Compact Piston Seals

Description

The Compact Seal is a double-acting seal and guide element comprising an elastomeric profile seal ring, two back-up rings and two guide rings. The profile seal ring seals in both the static and dynamic range whilst the back-up rings prevent extrusion into the sealing gap. The function of the guide rings is to guide the piston in the cylinder tube and to absorb transverse forces. The design provides a compact seal and guide combination for a closed or split installation groove.

Designs

The Compact Seal is available in various profile geometries which are in practical use. The choice is normally determined by the existing installation grooves.

DAS Type A

This type is characterized by the straight, long-sided L-profiles of the guide rings. Compared with Type B, it exhibits a smaller groove depth with the same cylinder diameter.

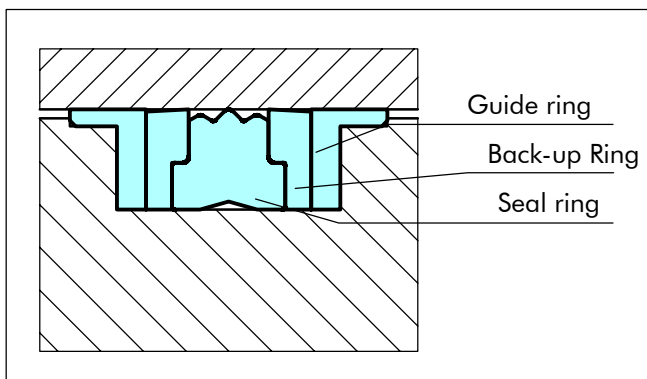

Figure 39 D-A-S Compact Seal, Type A

DAS Type B

This type is characterized by a Z-shaped back-up ring which forms a chamber with the elastomer seal ring on the inside and is centered on the outside by the guide ring.

For many piston diameters, the width of the guide ring (dimension L2) can be selected due to sideloads.

Due to the larger groove depth, the profile of the seal ring is more rigid than that of Type A and requires higher installation forces.

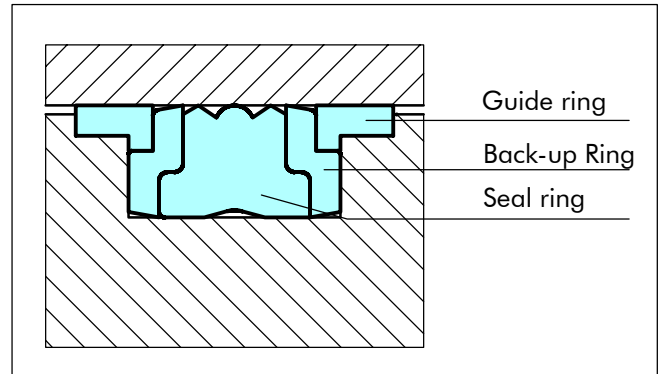

Figure 40 D-A-S Compact Seal, Type B

Polypac® DBM

The DBM Compact seal profile is characterized by a concave-shaped Back-up ring that prevents the elastomer profile ring from deformation and/or extrusion. The Back-up ring is centered on the outside by the guide ring.

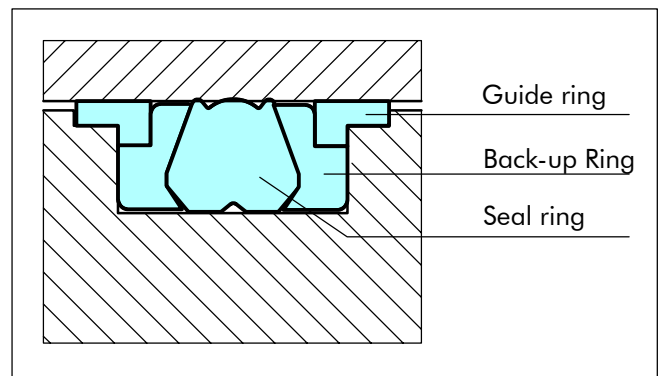

Figure 41 DBM Compact Seal

Advantages

- Good sealing effect, also suitable for holding cylinders
- Capable of installation in closed grooves for reduced machining costs
- Economic sealing and guiding solution
- Simple snap installation.



Compact Seal

Application Examples

The Compact seals are the recommended sealing element for double acting pistons of hydraulic components such as:

- Machine tools
- Truck cranes
- Forklifts & handling machinery
- Agriculture equipment

Technical Data

Operating conditions

pressure: Up to 35 MPa peak up to 40 MPa

Speed: Up to 0.5 m/s

Temperature: -30°C to +100°C

Media: Mineral oil-based hydraulic fluids, flame retardant hydraulic fluids, HFA, HFB, HFC (< +40°C)

Important Note:

The above data are maximum values and cannot be used at the same time. e.g. the maximum operating speed depends on material type, pressure, temperature and gap value. Temperature range also dependent on medium.

Ordering Example

Bore diameter: $D_N = 80.0$ mm

Groove diameter: $d_1 = 60.0$ mm

Groove width: $L_1 = 22.4$ mm

DAS Type B

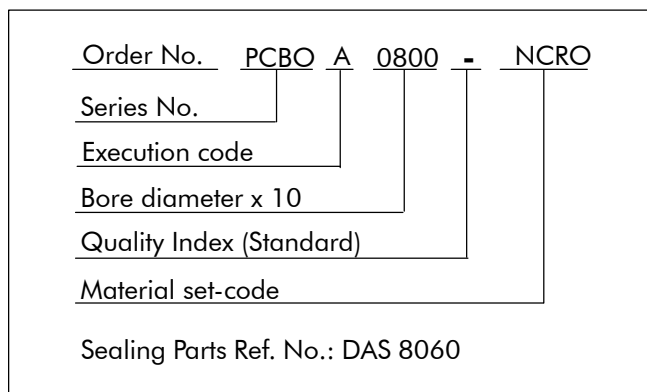

Materials

- The D-A-S Compact Seal is available in the following material combinations:

Profile seal: NBR 70 Shore A

Back-up Ring: Polyester elastomer

Guide rings: POM

Set ref.: NCRO

- The DBM Compact Seal is available in the following material combination:

Profile seal: NBR 80 Shore A

Back-up Ring: Polyester elastomer

Guide rings: POM

Set reference: N8UO

Polypac DBM

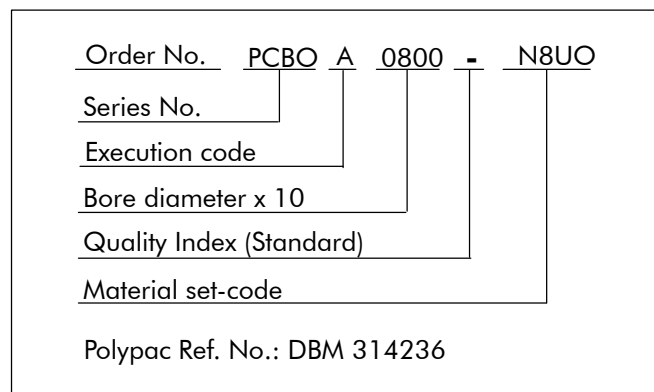



Installation Recommendation, DAS Type A

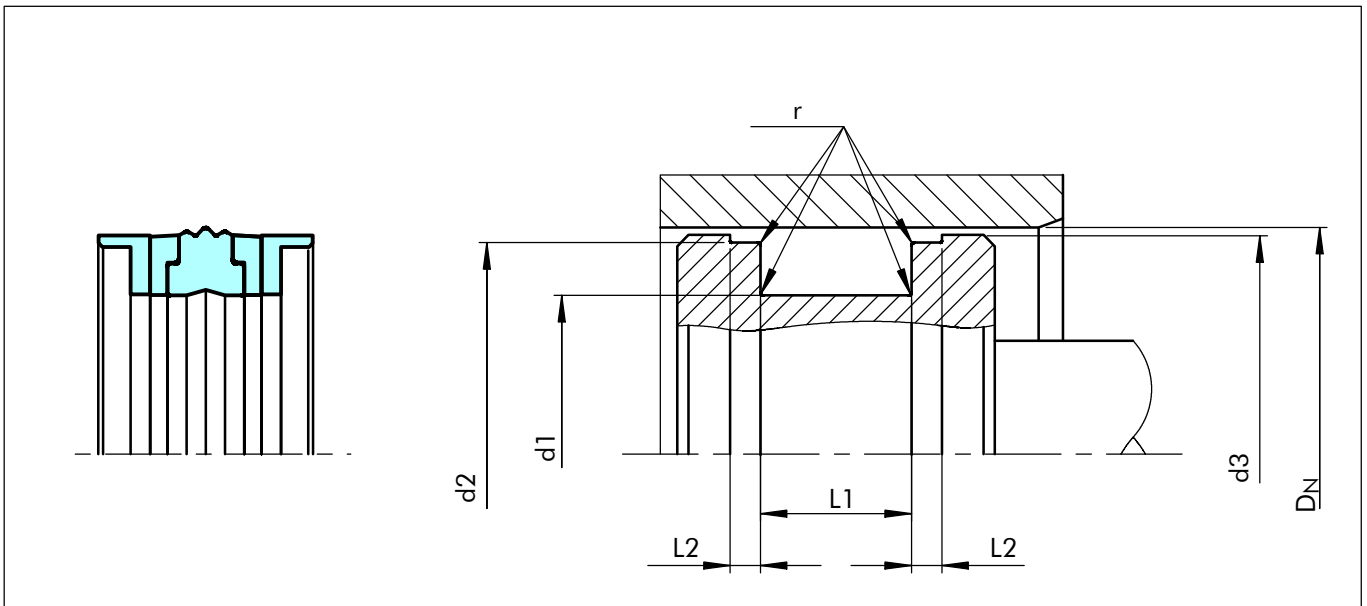

Figure 42 Installation drawing

Table XLIII Installation dimensions / Order No.

Bore Dia. D_N H9	Groove Dimensions						Order No.	Sealing Parts Ref. No.
	$d1$ h9	$d2$ h9	$L1$ +0,2	$d3$ h11	$L2$ +0.1	r max		
32.0	24.0	28.0	15.5	31.4	3.2	0.4	PCA200320-NCRO	DAS 32 24
40.0	32.0	36.0	15.5	39.4	3.2	0.4	PCA400400-NCRO	DAS 40 32
50.0	38.0	46.0	20.5	49.4	4.2	0.4	PCA200500-NCRO	DAS 50 38
60.0	48.0	56.0	20.5	59.4	4.2	0.4	PCA200600-NCRO	DAS 60 48
63.0	51.0	59.0	20.5	63.4	4.2	0.4	PCA300630-NCRO	DAS 63 51
70.0	58.0	66.0	20.5	69.4	4.2	0.4	PCA200700-NCRO	DAS 70 58
80.0	66.0	76.0	22.5	79.4	5.2	0.4	PCA200800-NCRO	DAS 80 66
90.0	76.0	86.0	22.5	89.4	5.2	0.4	PCA200900-NCRO	DAS 90 76
100.0	86.0	96.0	22.5	99.4	5.2	0.4	PCA201000-NCRO	DAS 100 86
110.0	96.0	106.0	22.5	109.4	5.2	0.4	PCA201100-NCRO	DAS 110 96
120.0	106.0	116.0	22.5	119.4	5.2	0.8	PCA101200-NCRO	DAS 120 106
125.0	108.0	121.0	26.5	124.4	7.2	0.8	PCA201250-NCRO	DAS 125 108
130.0	113.0	126.0	26.5	129.4	7.2	0.8	PCA201300-NCRO	DAS 130 113
140.0	123.0	136.0	26.5	139.4	7.2	0.8	PCA301400-NCRO	DAS 140 123
150.0	133.0	146.0	26.5	149.4	7.2	0.8	PCA301500-NCRO	DAS 150 133
160.0	143.0	156.0	26.5	159.4	7.2	0.8	PCA301600-NCRO	DAS 160 143



Compact Seal

Installation Recommendation, D A S Type B and Polypac® DBM

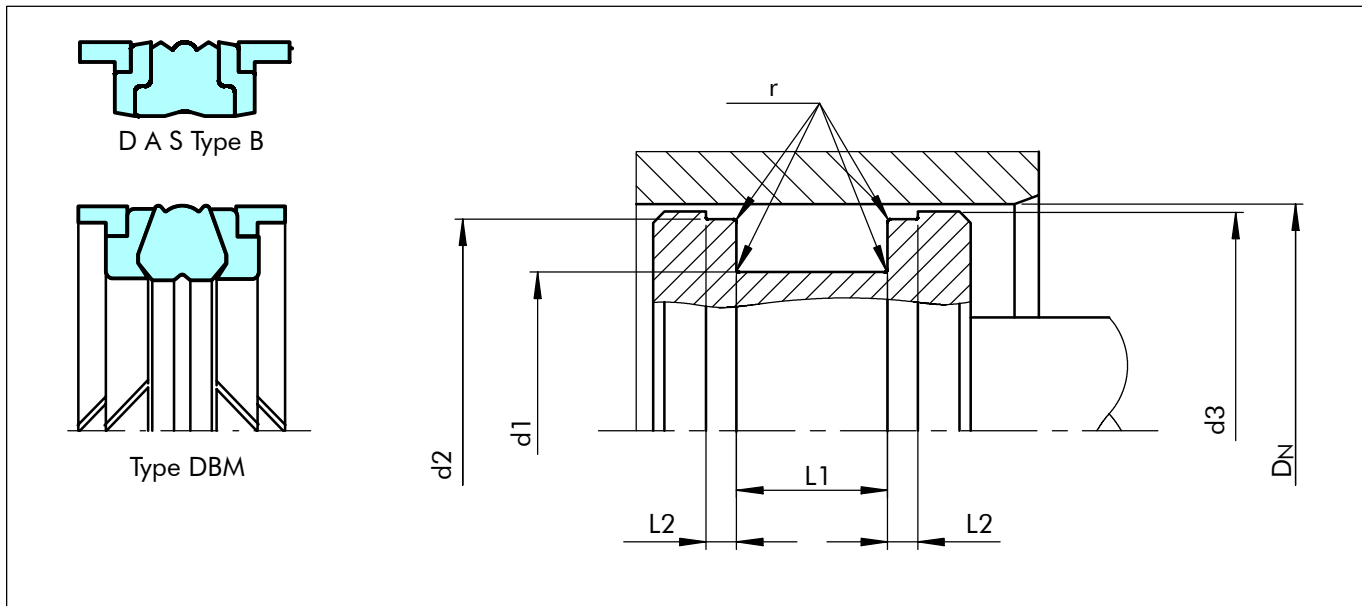

Figure 43 Installation drawing

Table XLIV Installation dimensions / Order No.

Bore Dia.	Groove Dimensions						Part No.	B+S Ref.	Polypac Ref. No.	Sealing Parts Ref. No.				
	D_N H9	d1 h9	L1+0.2	d2 h9	d3 h11	L2 +0.1					r max	Material code		
												NCRO	N8UO	NCRO
20.0	11.00	13.50	17.00	19.00	2.10	0.40	PCB 0N0200	*		DAS 2011				
22.0	13.00	13.50	19.00	21.00	2.10	0.40	PCB 0N0220	*		DAS 22 13				
25.0	15.00	12.00	21.00	23.00	4.00	0.40	PCB 0D0250	*		DAS 25 15/1				
25.0	15.00	12.50	22.00	24.00	4.00	0.40	PCB 1N0250	*		DAS 25 15/2				
25.0	15.00	16.40	21.45	23.50	6.35	0.40	PCB 1N0250	*	DBM 098 059	DAS 25 15				
25.0	16.00	13.50	22.00	24.00	2.10	0.40	PCB 2N0250	*		DAS 25 16				
28.0	19.00	13.50	25.00	27.00	2.10	0.40	PCB 0N0280	*		DAS 28 19				
30.0	17.00	15.40	26.50	28.50	6.35	0.40	PCB 000300	*	DBM 118 066					
30.0	21.00	13.50	27.00	29.00	2.10	0.40	PCB 0A0300	*		DAS 30 21				
32.0	22.00	15.50	28.00	31.00	2.60	0.40	PCB 0B0320	*		DAS 32 22/1				
32.0	22.00	16.40	28.50	30.50	6.35	0.40	PCB 1A0320	*	DBM 125 086	DAS 32 22				
35.0	25.00	15.50	31.00	34.00	2.60	0.40	PCB 0B0350	*		DAS 35 25/1				
35.0	25.00	16.40	31.40	33.50	6.35	0.40	PCB 1A0350	*	DBM 137 098	DAS 35 25				
40.0	24.00	18.40	35.40	38.50	6.35	0.40	PCB 0A0400	*	DBM 157 094	DAS 40 24				
40.0	26.00	15.50	36.00	39.00	2.60	0.40	PCB 1A0400	*	DBM 157 102/M	DAS 40 26				
40.0	30.00	12.50	36.00	38.00	4.00	0.40	PCB 2D0400	*		DAS 40 30/1				
40.0	30.00	12.50	37.00	39.00	4.00	0.40	PCB 2E0400	*		DAS 40 30/2				
40.0	30.00	16.40	35.40	38.50	6.35	0.40	PCB 3A0400	*	DBM 157 118	DAS 40 30				
42.0	28.00	15.50	38.00	41.00	2.60	0.40	PCB 0N0420	*		DAS 42 28				
45.0	29.00	18.40	40.40	43.50	6.35	0.40	PCB 0N0450	*	DBM 177 114	DAS 45 29				
45.0	31.00	15.50	41.00	44.00	2.60	0.40	PCB 1A0450	*		DAS 45 31				

* B+S mold available, same ref. as Part No. The listed products are technically equivalent but availability and pricing may vary. The bore diameters in **bold** type comply with the recommendations of ISO 6547. Imperial (inch) sizes can be supplied.

Compact Seal



Bore Dia.	Groove Dimensions						Part No.	B+S Ref.	Polypac Ref. No.	Sealing Parts Ref. No.				
	D _N H9	d1 h9	L1 +0.2	d2 h9	d3 h11	L2 +0.1					r max	Material code		
												NCRO	N8UO	NCRO
45.0	35.00	16.40	40.40	43.50	6.35	0.40	PCB 2N0450	*	DBM 177137	DAS 45 35				
50.0	34.00	18.40	45.40	48.50	6.35	0.40	PCB 1A0500	*	DBM 196 133	DAS 50 34				
50.0	34.00	20.50	46.00	49.00	3.10	0.40	PCB 0B0500	*	DBM 196 133/M	DAS 50 34/1				
55.0	39.00	18.40	50.36	53.50	6.35	0.40	PCB 1A0550	*	DBM 216 153	DAS 55 39				
55.0	39.00	20.50	51.00	54.00	3.10	0.40	PCB 0B0550	*		DAS 5539/1				
56.0	40.00	20.50	52.00	55.00	3.10	0.40	PCB 0A0560	*		DAS 56 40				
60.0	44.00	18.40	55.40	58.50	6.35	0.40	PCB 1A0600	*	DBM 236 173	DAS 60 44				
60.0	44.00	20.50	56.00	59.00	3.10	0.40	PCB 0B0600	*	DBM 236 173/M	DAS 60 44/1				
63.0	47.00	18.40	58.40	61.50	6.35	0.40	PCB 1A0630	*	DBM 248 185	DAS 63 47				
63.0	47.00	19.40	58.40	61.50	6.35	0.40	PCB 2C0630	*		DAS 63 47/2				
63.0	47.00	20.50	59.00	62.00	3.10	0.40	PCB 0B0630	*	DBM 248 185/M	DAS 63 47/1				
65.0	49.00	20.50	61.00	64.00	3.10	0.40	PCB 0N0650	*	DBM 255 192/M	DAS 65 49				
65.0	50.00	18.40	60.40	63.50	6.35	0.40	PCB 1A0650	*	DBM 255 196	DAS 65 50				
70.0	50.00	22.40	64.20	68.30	6.35	0.40	PCB 0A0700	*	DBM 275 196	DAS 70 50				
70.0	54.00	20.50	66.00	69.00	3.10	0.40	PCB 1N0700	*	DBM 275 212/M	DAS 70 54				
75.0	55.00	22.40	69.20	73.30	6.35	0.40	PCB 0A0750	*	DBM 295 216	DAS 75 55				
75.0	59.00	20.50	71.00	74.00	3.10	0.40	PCB 1A0750	*		DAS 75 59				
80.0	60.00	22.40	74.15	78.30	6.35	0.40	PCB 0A0800	*	DBM 314 236	DAS 80 60				
80.0	62.00	22.50	76.00	79.00	3.60	0.40	PCB 1A0800	*	DBM 314 244/M	DAS 80 62				
85.0	65.00	22.40	79.15	83.30	6.35	0.40	PCB 0A0850	*	DBM 334 255	DAS 85 65				
90.0	70.00	22.40	84.15	88.30	6.35	0.40	PCB 0A0900	*	DBM 354 275	DAS 90 70				
90.0	72.00	22.50	86.00	89.00	3.60	0.40	PCB 1A0900	*		DAS 90 72				
95.0	75.00	22.40	89.15	93.30	6.35	0.40	PCB 0A0950	*	DBM 374 295	DAS 95 75				
100.0	75.00	22.40	93.15	98.00	6.35	0.40	PCB 0A1000	*	DBM 393 295	DAS 100 75				
100.0	82.00	22.50	96.00	99.00	3.60	0.40	PCB 1A1000	*	DBM 393 332/M	DAS 100 82				
105.0	80.00	22.40	98.10	103.00	6.35	0.40	PCB 0A1050	*	DBM 413 314	DAS 105 80				
110.0	85.00	22.40	103.10	108.00	6.35	0.40	PCB 0A1100	*	DBM 433 334	DAS 110 85				
110.0	92.00	22.50	106.00	109.00	3.60	0.40	PCB 1A1100	*		DAS 110 92				
115.0	90.00	22.40	108.10	113.00	6.35	0.40	PCB 0A1150	*	DBM 452 354	DAS 115 90				
115.0	97.00	22.50	111.00	114.00	3.60	0.40	PCB 1N1150	*		DAS 115 97				
120.0	95.00	22.40	113.10	118.10	6.35	0.80	PCB 0A1200	*	DBM 472 374	DAS 120 95				
125.0	100.00	25.40	118.10	123.00	6.35	0.80	PCB 0A1250	*	DBM 492 393	DAS 125 100				
125.0	103.00	26.50	121.00	124.00	5.10	0.80	PCB 1A1250	*	DBM 492 405/M	DAS 125 103				
130.0	105.00	25.40	122.60	127.50	9.50	0.80	PCB 1A1300	*	DBM 511 413	DAS 130 105				
130.0	105.00	25.40	123.10	128.00	6.35	0.80	PCB 0B1300	*		DAS 130 105/1				
133.0	115.00	22.40	125.60	130.50	9.52	0.80	PCB 001330		DBM 523 452					
135.0	110.00	25.40	127.60	132.50	9.50	0.80	PCB 1A1350	*	DBM 531 433	DAS 135 110				
135.0	110.00	25.40	128.10	133.00	6.35	0.80	PCB 0B1350	*		DAS 135 110/1				
140.0	115.00	25.40	132.60	137.50	9.50	0.80	PCB 1A1400	*	DBM 551 452	DAS 140 115				
140.0	115.00	25.40	133.00	138.00	6.35	0.80	PCB 0B1400	*		DAS 140 115/1				
140.0	118.00	26.50	136.00	139.00	5.10	0.80	PCB 2A1400	*	DBM 551 464/M	DAS 140 118				
145.0	120.00	25.40	137.60	142.50	9.50	0.80	PCB 1A1450	*	DBM 570 472	DAS 145 120				
145.0	120.00	25.40	138.30	142.95	6.35	0.80	PCB 0B1450	*		DAS 145 120/1				
150.0	125.00	25.40	142.60	147.50	9.50	0.80	PCB 1A1500	*	DBM 590 492	DAS 150 125				
150.0	125.00	25.40	143.00	148.00	6.35	0.80	PCB0B1500	*		DAS 150 125/1				

* B+S mold available, same ref. as Part No. The listed products are technically equivalent but availability and pricing may vary. Imperial (inch) sizes can be supplied.



Compact Seal

Bore Dia. D _N H9	Groove Dimensions						Part No.	B+S Ref.	Polypac Ref. No.	Sealing Parts Ref. No.			
	d1 h9	L1 +0.2	d2 h9	d3 h11	L2 +0.1	r max					Material code		
											NCRO	N8UO	NCRO
150.0	128.00	26.50	146.00	149.00	5.10	0.80	PCB 2A1500	*		DAS 150 128			
152.4	127.00	31.75	145.00	149.91	9.50	0.80	PCB 001524		DBM 600 500				
155.0	130.00	25.40	147.60	152.50	9.50	0.80	PCB 0A1550	*	DBM 610511	DAS 155 130			
155.0	130.00	25.40	148.00	153.00	6.35	0.80	PCB 1B1550	*		DAS 155 130/1			
160.0	130.00	25.40	153.00	157.50	6.35	0.80	PCB 0A1600	*		DAS 160 130			
160.0	130.00	25.40	152.60	157.50	9.50	0.80	PCB 1A1600	*	DBM 629 511	DAS 160 130/1			
160.0	135.00	25.40	152.60	157.50	9.50	0.80	PCB 1A1600	*	DBM 629 531	DAS 160 135			
160.0	138.00	26.50	156.00	159.00	5.10	0.80	PCB 2A1600	*		DAS 160 138			
165.0	140.00	25.40	157.60	162.50	9.50	0.80	PCB 0A1650	*	DBM 649 551	DAS 165 140			
170.0	145.00	25.40	161.70	167.10	12.70	0.80	PCB 0A1700	*	DBM 669 570	DAS 170 145			
170.0	148.00	26.50	166.00	169.00	5.10	0.80	PCB 1A1700	*		DAS 170 148			
175.0	150.00	25.40	166.70	172.10	12.70	0.80	PCB 0A1750	*	DBM 688 590	DAS 175 150			
180.0	150.00	35.40	172.95	177.87	6.35	0.80	PCB 0A1800	*		DAS 180 150			
180.0	155.00	25.40	171.70	177.10	12.70	0.80	PCB 1A1800	*	DBM 708 610	DAS 180 155			
185.0	160.00	25.40	176.70	182.10	12.70	0.80	PCB 0A1850	*	DBM 728 629	DAS 185 160			
190.0	165.00	25.40	181.70	187.00	12.70	0.80	PCB 0A1900	*	DBM 748 649	DAS 190 165			
195.0	170.00	25.40	186.70	192.00	12.70	0.80	PCB 0A1950	*	DBM 767 669	DAS 195 170			
200.0	175.00	25.40	191.60	197.00	12.70	0.80	PCB 0A2000	*	DBM 787 688	DAS 200 175			
200.0	175.00	31.50	196.00	199.00	6.60	0.80	PCB 102000		DBM 787 688/M				
210.0	185.00	25.40	201.60	207.00	12.70	0.80	PCB 0A2100	*	DBM 826 728	DAS 210 185			
220.0	190.00	35.40	212.70	217.90	6.35	0.80	PCB 0A2200	*		DAS 220 190			
220.0	195.00	25.40	211.60	217.00	12.70	0.80	PCB 1A2200	*	DBM 866 767	DAS 220 195			
230.0	205.00	25.40	221.60	227.00	12.70	0.80	PCB 0A2300	*	DBM 905 807	DAS 230 205			
240.0	215.00	25.40	231.60	237.00	12.70	0.80	PCB 0A2400	*	DBM 944 846	DAS 240 215			
250.0	220.00	35.40	242.90	247.85	6.35	0.80	PCB 0A2500	*		DAS 250 220			
250.0	225.00	25.40	241.60	247.00	12.70	0.80	PCB 1A2500	*	DBM 984 886	DAS 250 225			

* B+S mold available, same ref. as Part No. The listed products are technically equivalent but availability and pricing may vary.
Imperial (inch) sizes can be supplied.

ZURCON[®] COMPACT SEALS

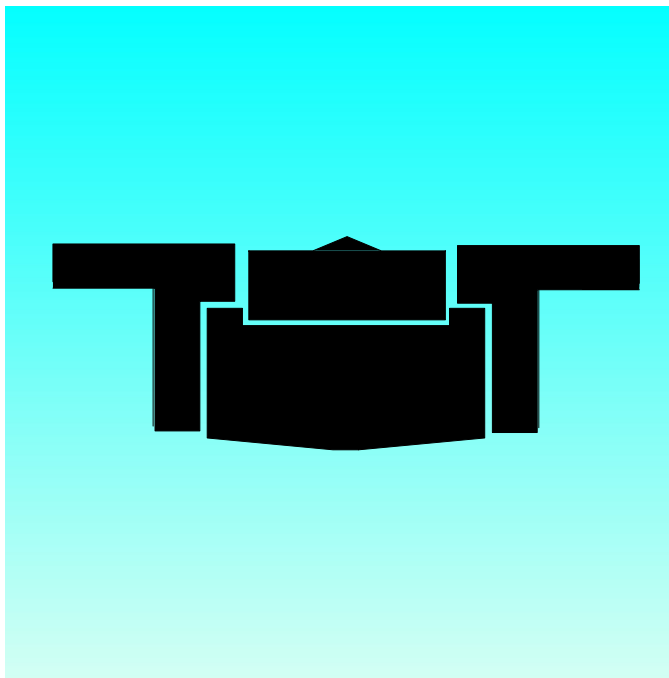

- Double Acting -

- Combined Seal and Guide Element -

- Material -

- Zurcon[®] Polyurethane, NBR + POM -





■ PU DAS and Polypac® EUD

Description

The Compact Seals are double-acting piston seals with integrated guide rings. The combination of the elastomer energiser and the polyurethane special shaped sealing element provide excellent sealing effect and service life. The function of the guide rings is to guide the piston in the cylinder tube and to absorb transverse forces.

Type PU DAS

For the Compact Seal PU DAS is designed without Back-up rings. For easy installation in closed grooves, the combination into one stiff sealing element and one soft energizing element is required. Back-up rings are unnecessary thanks to the high extrusion resistance of the polyurethane material.

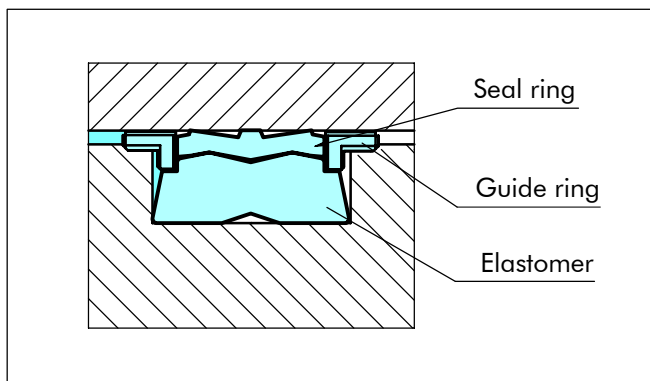

Figure 44 Compact Seal, Type PU DAS

Type Polypac® EUD

The Compact Seal EUD design includes T-shaped Back-up/guide rings and a combination of seal ring and energiser.

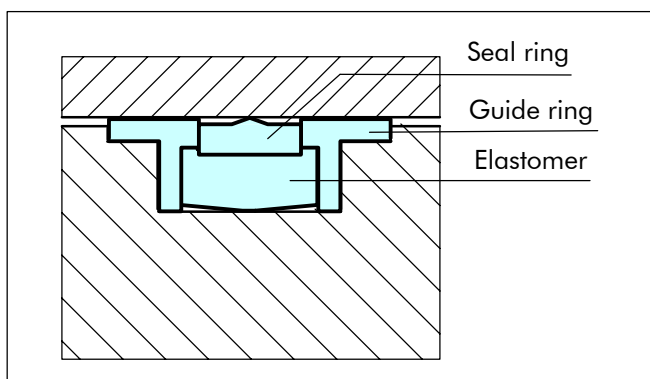

Figure 45 Compact Seal, Type EUD

Advantages

- High wear resistance
- Low compression set
- Optimal leakage control
- Easy installation into closed grooves
- Excellent service life

Application Examples

The Zurcon® Compact seals are the recommended sealing element for double acting pistons of hydraulic cylinders for:

- Truck cranes
- Mini excavators
- Heavy duty cylinders

Technical Data

Operating conditions

Pressure: Up to 40 MPa

Speed: Up to 0.5 m/s

Temperature: -35°C to +110°C

Media: Mineral oil based hydraulic fluids

Important Note:

The above data are maximum values and cannot be used at the same time. e.g. the maximum operating speed depends on material type, pressure, temperature and gap value. Temperature range also dependent on medium.

Materials

- The Polyurethane Compact seals PU DAS and EUD are available in the following composition:

Sealing ring: Zurcon® Polyurethane 93 Shore A

Energiser: NBR
 70 Shore A Type PU DAS
 78 Shore A Type EUD

Guide rings: POM

Set references: Z2052



■ Installation Recommendation, (PU DAS)

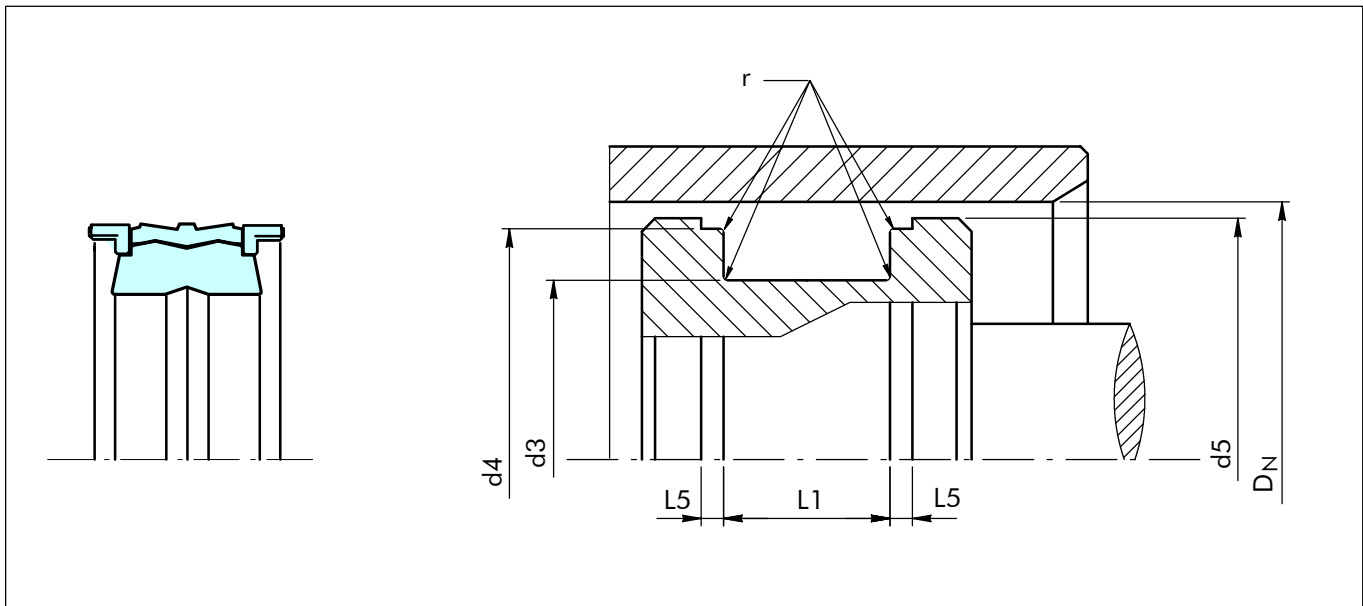
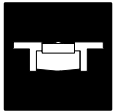

Figure 46 Installation drawing

Table XLV Installation dimensions / Order No.

Bore Dia. D _N H9	Groove Dimensions					Piston Dia. d ₅ h11	Order No.
	d ₃ h9	d ₄ h9	L ₁ +0.2	L ₅ +0.1	r max.		
40.0	26.0	36.00	15.5	2.60	0.4	38.50	PCC000400 - Z2052
45.0	31.0	41.00	15.5	2.60	0.4	44.00	PCC000450 - Z2052
50.0	34.0	46.00	20.5	3.10	0.4	49.00	PCC000500 - Z2052
55.0	39.0	51.00	20.5	3.10	0.4	54.00	PCC000550 - Z2052
60.0	44.0	56.00	20.5	3.10	0.4	59.00	PCC000600 - Z2052
63.0	47.0	59.00	20.5	3.10	0.4	62.00	PCC000630 - Z2052
65.0	49.0	61.00	20.5	3.10	0.4	64.00	PCC000650 - Z2052
70.0	54.0	66.00	20.5	3.10	0.4	69.00	PCC000700 - Z2052
75.0	59.0	71.00	20.5	3.10	0.4	74.00	PCC000750 - Z2052
80.0	62.0	76.00	22.5	3.60	0.4	79.00	PCC000800 - Z2052
90.0	72.0	86.00	22.5	3.60	0.4	89.00	PCC000900 - Z2052
100.0	82.0	96.00	22.5	3.60	0.4	99.00	PCC001000 - Z2052
110.0	92.0	106.00	22.5	3.60	0.4	109.00	PCC001100 - Z2052
125.0	103.0	121.00	26.5	5.10	0.8	124.00	PCC001250 - Z2052
140.0	118.0	136.00	26.5	5.10	0.8	139.00	PCC001400 - Z2052
150.0	128.0	146.00	26.5	5.10	0.8	149.00	PCC001500 - Z2052
160.0	138.0	156.00	26.5	5.10	0.8	159.00	PCC001600 - Z2052
165.0	143.0	161.00	26.5	5.10	0.8	164.00	PCC001650 - Z2052
170.0	148.0	166.00	26.5	5.10	0.8	169.00	PCC001700 - Z2052
180.0	158.0	176.00	26.5	5.10	0.8	179.00	PCC001800 - Z2052
200.0	175.0	196.00	31.5	6.60	0.8	199.00	PCC002000 - Z2052
250.0	220.0	242.90	35.4	6.35	0.8	248.00	PCC002500 - Z2052
270.0	240.0	262.90	35.4	6.35	0.8	267.00	PCC002700 - Z2052



■ Installation Recommendation, Type EUD

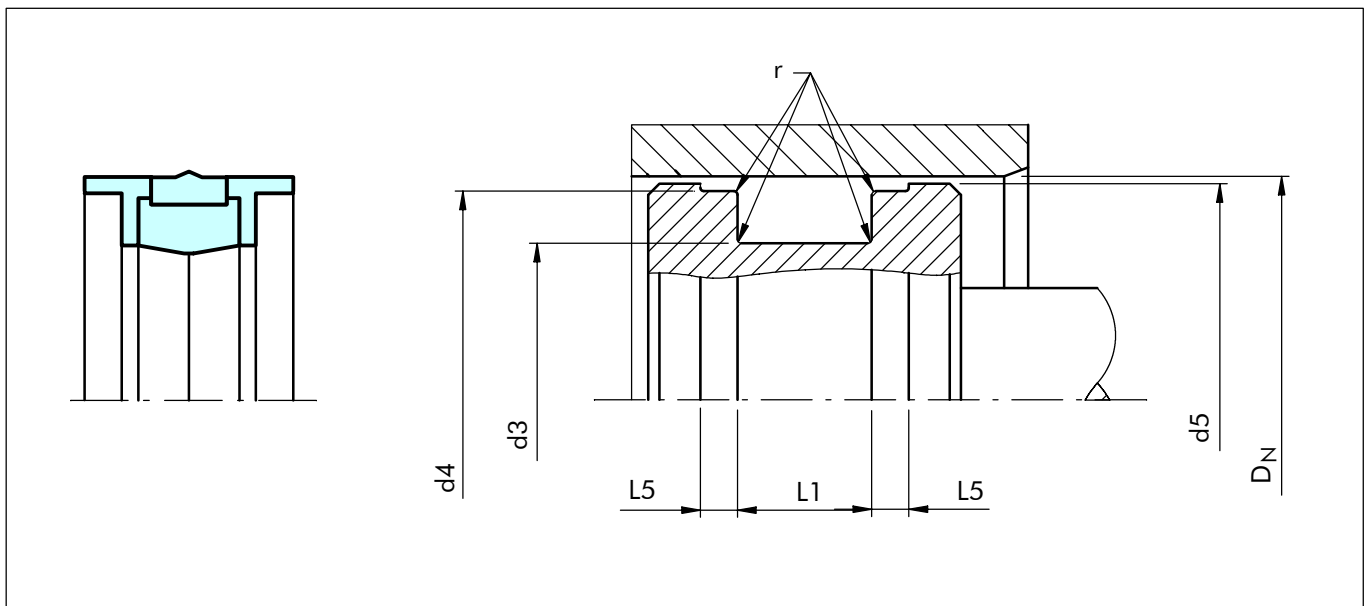

Figure 47 Installation drawing

Table XLVI Installation dimensions / Order No.

Bore Dia. D _N H9	Groove Dimensions					Piston Dia. d ₅ h11	Order No.	Polypac Ref. No.
	d ₃ h9	d ₄ h9	L ₁ +0.2	L ₅ +0.1	r max.			
40.0	32.0	36.0	10.0	4.2	0.2	39.40	PCG000400-Z2052	EUD4032/1
50.0	38.0	46.0	20.5	4.2	0.2	49.40	PCG000500-Z2052	EUD5038
50.0	40.0	46.0	12.5	4.2	0.2	49.40	PCG100500-Z2052	EUD5040/1
55.0	43.0	51.0	20.5	4.2	0.2	54.40	PCG000550-Z2052	EUD5543
60.0	48.0	56.0	20.5	4.2	0.2	59.40	PCG000600-Z2052	EUD6048
63.0	51.0	59.0	20.5	4.2	0.2	62.40	PCG000630-Z2052	EUD6351
65.0	53.0	61.0	20.5	4.2	0.2	64.40	PCG000650-Z2052	EUD6553
65.0	55.0	61.0	12.5	4.2	0.2	64.40	PCG100650-Z2052	EUD6555/1
70.0	58.0	66.0	20.5	4.2	0.2	69.40	PCG000700-Z2052	EUD7058
80.0	66.0	76.0	22.5	5.2	0.2	79.40	PCG000800-Z2052	EUD8066
85.0	71.0	81.0	22.5	5.2	0.2	84.40	PCG000850-Z2052	EUD8571
90.0	76.0	86.0	22.5	5.2	0.2	89.40	PCG000900-Z2052	EUD9076
100.0	86.0	96.0	22.5	5.2	0.2	99.40	PCG001000-Z2052	EUD10086
110.0	96.0	106.0	22.5	5.2	0.2	109.40	PCG001100-Z2052	EUD11096
120.0	106.0	116.0	22.5	5.2	0.2	119.40	PCG001200-Z2052	EUD120106
125.0	108.0	121.0	26.5	7.2	0.4	124.40	PCG001250-Z2052	EUD125108
140.0	123.0	136.0	26.5	7.2	0.4	139.40	PCG001400-Z2052	EUD140123
160.0	143.0	156.0	26.5	7.2	0.4	159.40	PCG001600-Z2052	EUD160143



Zurcon[®] Compact Seal

COMPACT SEAL POLYPAC[®] - DUOPAC DPS/DPC

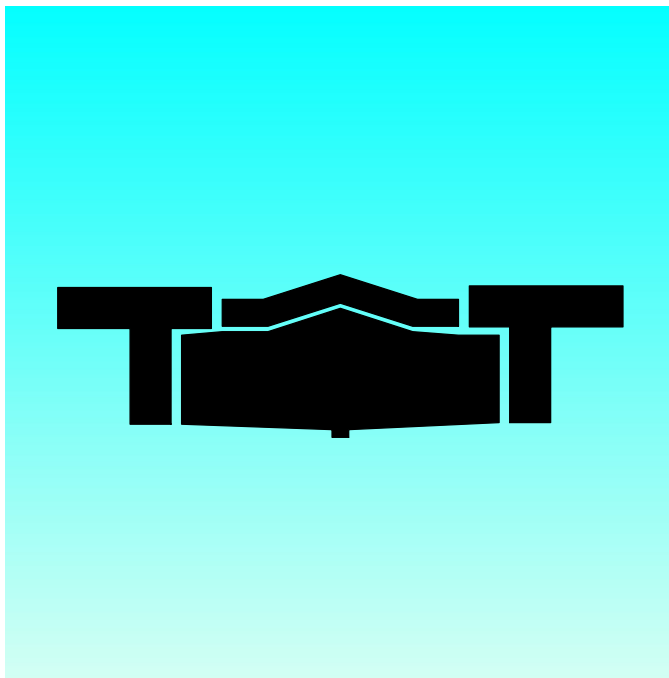

- Double Acting -
- Combined Seal and Guide Element -
- Material -
- Rubber Fabric Reinforced NBR and POM -





DUOPAC rubber fabric reinforced compact seals Type DPS and DPC

Description

The compact seals DUOPAC DPS and DPC types are double acting piston seals with integrated guide rings. DUOPAC has been designed to optimize the advantages of the materials selection:

- Fabric reinforcement with high mechanical strength, optimum thermal stability and lubricating properties is incorporated in the sealing element all over the dynamic contact area. For the DUOPAC DPC the reinforcement is extended on both sides to improve the extrusion resistance
- Nitrile based elastomer with optimum elasticity and low compression set provides the initial radial pre-load
- Acetal resin with improved form stability gives the Guide/backup rings high distortion and extrusion resistance

Type DPS

The DPS profile has been designed for its installation in closed grooves. The radial dimension of the profile has been reduced to the minimum to allow the necessary deformation during installation in closed grooves. Consequently its use must be limited to pressures up to 35 MPa.

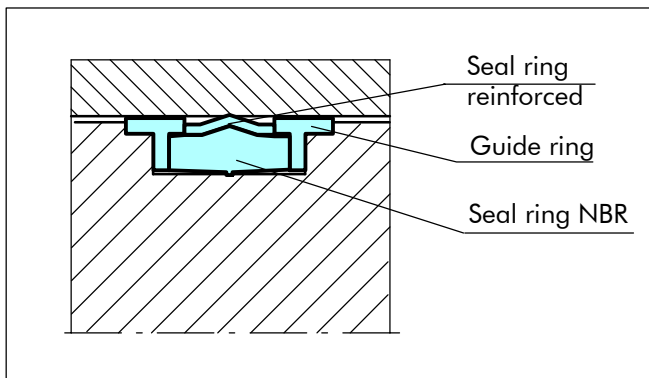

Figure 48 Compact Seal, Type DPS

Type DPC

The DPC profile is much more robust and can therefore be used for pressure level up to 70 MPa.

An open groove is necessary.

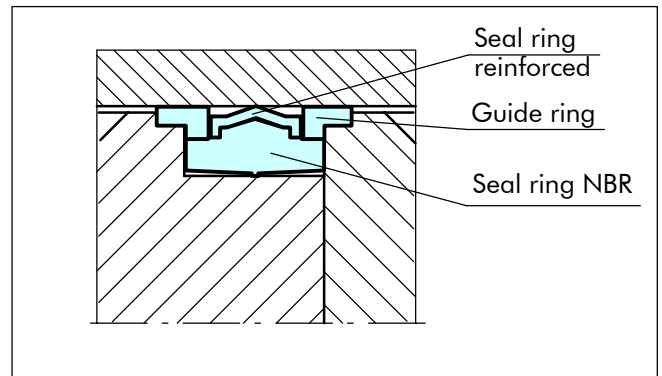

Figure 49 Compact Seal, Type DPC

Advantages

- DPS can be installed into closed grooves but its use must consequently be limited to medium duty applications
- DPC are usually installed in open grooves in Heavy Duty applications (pressure peak up to 80MPa)
- Improved abrasion resistance
- Excellent sealing effect in combination with good dynamic and static friction behavior

Application Examples

The Compact seals are the recommended Sealing element for double acting Pistons of hydraulic components in following applications:

- Mining cylinders
- Presses
- Steel mills equipment
- Water hydraulic cylinders



Compact Seal

Technical Data

Operating conditions:

For an optimum performance of the DUOPAC, the recommended tolerances and surface finish must be applied.

Pressure: Up to 35MPa DPS type
Up to 70MPa DPC type

Speed: Up to 0.5 m/s

Temperature: -30°C to +130°C

Media: Mineral oil based hydraulic fluids,
water/oil and water/glycol emulsions.

Important Note:

The above data are maximum values and cannot be used at the same time. e.g. the maximum operating speed depends on material type, pressure, temperature and gap value. Temperature range also dependent on medium.

Materials

- The compact seals DUOPAC are available in the following material composition:

Sealing element: Rubber fabric reinforced NBR

Guide/Back-up Rings: POM

Material set-code: N00OC

Ordering Example

Compact Seal Type DPS

Bore diameter: $D_N = 80$ mm

Groove diameter: $d1 = 66$ mm

Groove width: $L1 = 22.5$ mm

Part No.: PCE100800 (from Table XLVII)

Material set-code: N00OC

Order No. PCE1 0 0800 - N00OC
Series No. _____
Type (Standard) _____
Bore diameter x 10 _____
Quality Index (Standard) _____
Material set-code _____

Polypac Ref. No.: DPS 8066

Ordering Example

Compact Seal Type DPC

Bore diameter: $D_N = 80$ mm

Groove diameter: $d1 = 60$ mm

Groove width: $L1 = 22.4$ mm

Part No.: PCF000800 (from Table XLVIII)

Material set-code: N00OC

Order No. PCF0 0 0800 - N00OC
Series No. _____
Type (Standard) _____
Bore diameter x 10 _____
Quality Index (Standard) _____
Material set-code _____

Polypac Ref. No.: DPC 8060



■ Installation Recommendation, Type DPS

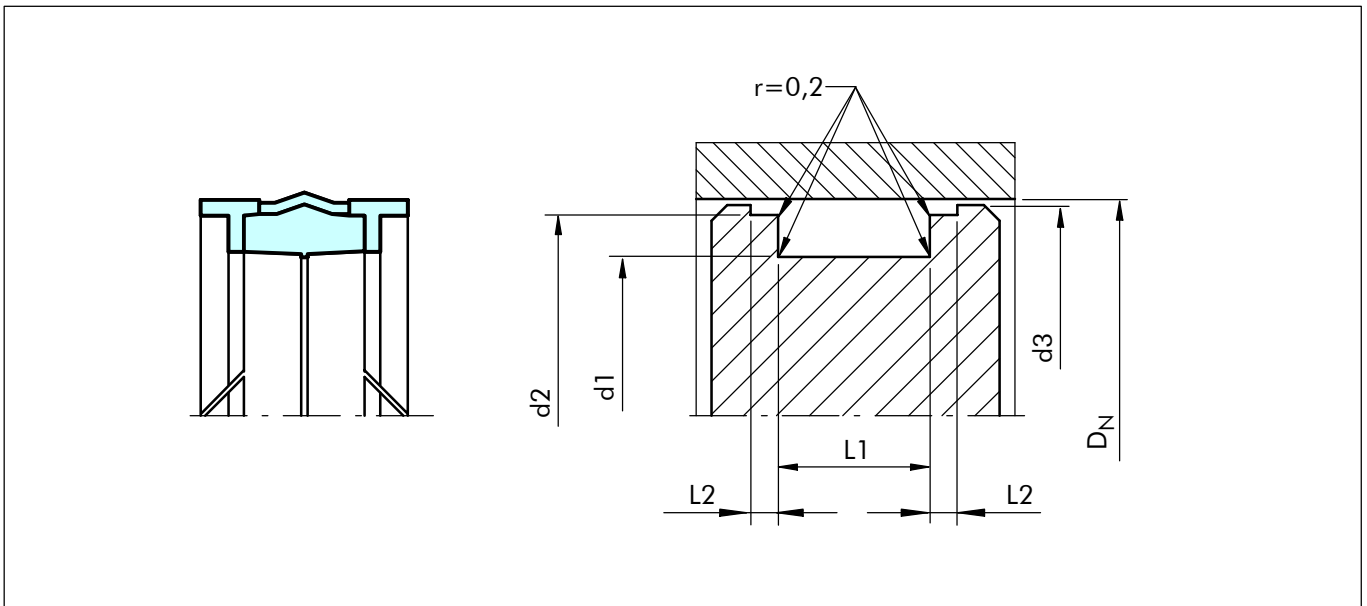

Figure 50 Installation drawing

Table XLVII Installation dimensions / Order No.

Bore Dia. D_N H11	Groove Dimensions					Order No.	Polypac Ref. No.
	$d1$ h9	$L1 +0.2$	$L2+0.1$	$d2$ h9	$d3$ h11		
25.0	17.0	10.0	4.0	22.0	24.0	PCE000250-N00OC	DPS 2517/1
32.0	24.0	15.5	3.2	28.0	31.4	PCE000320-N00OC	DPS 3224
32.0	24.0	10.0	4.0	29.0	31.0	PCE100320-N00OC	DPS 3224/1
35.0	27.0	15.5	3.2	31.0	34.4	PCE000350-N00OC	DPS 3527
40.0	32.0	15.5	3.2	36.0	39.4	PCE000400-N00OC	DPS 4032
40.0	32.0	10.0	4.0	37.0	39.0	PCE100400-N00OC	DPS 4032/1
45.0	37.0	15.5	3.2	41.0	44.4	PCE000450-N00OC	DPS 4537
50.0	38.0	20.5	4.2	46.0	49.4	PCE000500-N00OC	DPS 5038
50.0	40.0	12.5	4.0	47.0	49.0	PCE100500-N00OC	DPS 5040/1
55.0	43.0	20.5	4.2	51.0	54.4	PCE000550-N00OC	DPS 5543
60.0	48.0	20.5	4.2	56.0	59.4	PCE000600-N00OC	DPS 6048
63.0	51.0	20.5	4.2	59.0	62.4	PCE000630-N00OC	DPS 6351
63.0	53.0	12.5	4.0	60.0	62.0	PCE100630-N00OC	DPS 6353/1
65.0	53.0	20.5	4.2	61.0	64.4	PCE000650-N00OC	DPS 6553
70.0	58.0	20.5	4.2	66.0	69.4	PCE000700-N00OC	DPS 7058
75.0	63.0	20.5	4.2	71.0	74.4	PCE000750-N00OC	DPS 7563
80.0	65.0	20.0	5.0	76.0	78.5	PCE000800-N00OC	DPS 8065/1
80.0	66.0	22.5	5.2	76.0	79.4	PCE100800-N00OC	DPS 8066
85.0	71.0	22.5	5.2	81.0	84.4	PCE000850-N00OC	DPS 8571
90.0	76.0	22.5	5.2	86.0	89.4	PCE000900-N00OC	DPS 9076
100.0	85.0	20.0	5.0	96.0	98.5	PCE001000-N00OC	DPS 10085/1

The bore diameters in **bold** type comply with the recommendations of ISO 6547.



Compact Seal

Bore Dia.	Groove Dimensions					Order No.	Polypac Ref. No.
	D_N H11	$d1$ h9	$L1$ +0.2	$L2$ +0.1	$d2$ h9		
100.0	86.0	22.5	5.2	96.0	99.4	PCE101000-N00OC	DPS 10086
110.0	96.0	22.5	5.2	106.0	109.4	PCE001100-N00OC	DPS 11096
120.0	106.0	22.5	5.2	116.0	119.4	PCE001200-N00OC	DPS 120106
125.0	105.0	25.0	6.3	120.0	123.0	PCE001250-N00OC	DPS 125105/1
125.0	108.0	26.5	7.2	121.0	124.4	PCE101250-N00OC	DPS 125108
140.0	120.0	25.0	6.3	135.0	138.0	PCE001400-N00OC	DPS 140120/1
140.0	123.0	26.5	7.2	136.0	139.4	PCE101400-N00OC	DPS 140123
150.0	133.0	26.5	7.2	146.0	149.4	PCE001500-N00OC	DPS 150133
160.0	140.0	25.0	6.3	155.0	158.0	PCE001600-N00OC	DPS 160140/1
160.0	143.0	26.5	7.2	156.0	159.4	PCE101600-N00OC	DPS 160143
180.0	163.0	26.5	7.2	176.0	179.4	PCE001800-N00OC	DPS 180163
200.0	170.0	36.0	12.5	192.0	197.0	PCE002000-N00OC	DPS 200170/1
200.0	180.0	31.5	9.2	196.0	199.4	PCE102000-N00OC	DPS 200180
220.0	200.0	31.5	9.2	216.0	219.4	PCE002200-N00OC	DPS 220200
250.0	230.0	31.5	9.2	246.0	249.4	PCE002500-N00OC	DPS 250230

The bore diameters in **bold** type comply with the recommendations of ISO 6547.



■ Installation Recommendation, Type DPC

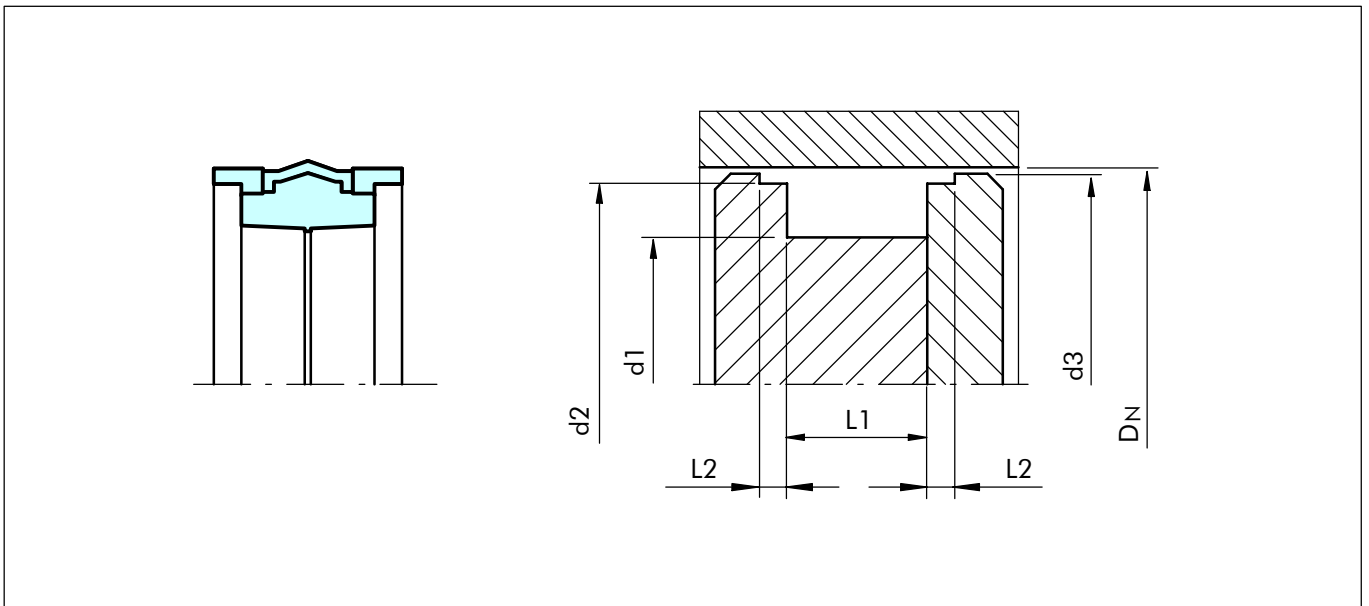

Figure 51 Installation drawing

Table XLVIII Installation dimensions / Order No.

Bore Dia. D_N H11	Groove Dimensions					Order No.	Polypac Ref. No.
	$d1$ h9	$L1$ +0.2	$L2$ +0.1	$d2$ h11	$d3$ h11		
30.0	17.0	15.4	6.35	26.50	29.00	PCF000300-N00OC	DPC 3017
35.0	22.0	15.4	6.35	31.40	33.70	PCF000350-N00OC	DPC 3522
40.0	24.0	18.4	6.35	35.40	38.70	PCF000400-N00OC	DPC 4024
45.0	29.0	18.4	6.35	40.40	43.70	PCF000450-N00OC	DPC 4529
50.0	34.0	18.4	6.35	45.40	48.70	PCF000500-N00OC	DPC 5034
55.0	39.0	18.4	6.35	50.40	53.70	PCF000550-N00OC	DPC 5539
60.0	44.0	18.4	6.35	55.40	58.70	PCF000600-N00OC	DPC 6044
65.0	50.0	18.4	6.35	60.40	63.70	PCF000650-N00OC	DPC 6550
70.0	50.0	22.4	6.35	64.20	68.30	PCF000700-N00OC	DPC 7050
75.0	55.0	22.4	6.35	69.20	73.30	PCF000750-N00OC	DPC 7555
80.0	60.0	22.4	6.35	74.20	78.30	PCF000800-N00OC	DPC 8060
85.0	65.0	22.4	6.35	79.20	83.30	PCF000850-N00OC	DPC 8565
90.0	70.0	22.4	6.35	84.15	88.30	PCF000900-N00OC	DPC 9070
95.0	75.0	22.4	6.35	89.15	93.30	PCF000950-N00OC	DPC 9575
100.0	75.0	22.4	6.35	93.15	98.05	PCF001000-N00OC	DPC 10075
100.0	80.0	25.4	6.35	94.15	98.30	PCF101000-N00OC	DPC 10080
105.0	85.0	22.4	6.35	98.10	103.00	PCF001050-N00OC	DPC 10585
110.0	85.0	22.4	6.35	103.10	108.00	PCF001100-N00OC	DPC 11085
120.0	100.0	25.4	6.35	114.10	118.00	PCF001200-N00OC	DPC 120100
130.0	105.0	25.4	6.35	123.10	128.00	PCF001300-N00OC	DPC 130105
140.0	115.0	25.4	6.35	133.00	138.00	PCF001400-N00OC	DPC 140115
150.0	125.0	25.4	6.35	143.00	148.00	PCF001500-N00OC	DPC 150125
160.0	135.0	33.0	6.35	153.00	158.00	PCF001600-N00OC	DPC 160135



Compact Seal

POLYPAC[®] - VEEPAC CH/G1

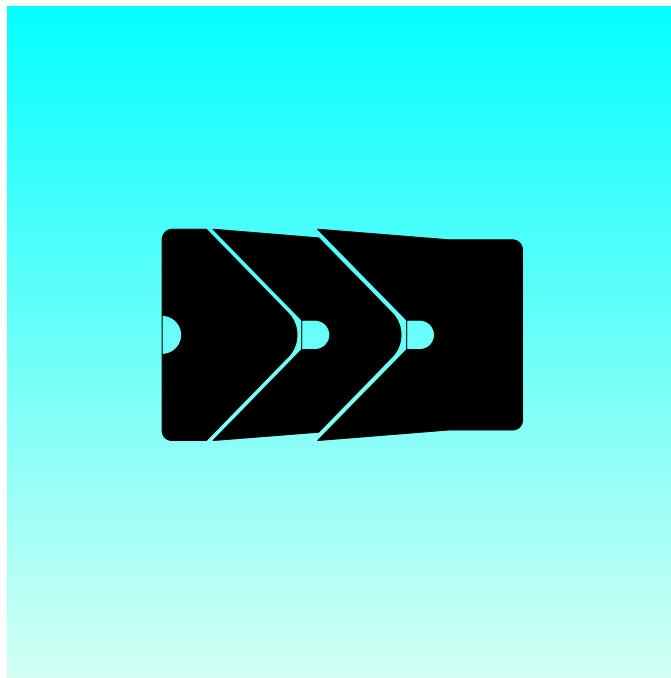

- **Single Acting** -
- **Chevron Ring** -
- **With Support and Pressure Energising Ring** -

- **Material** -
- **POM, PTFE, Fabric Reinforced Rubber** -





■ Veepac CH/G1

Description

Veepac G1 is a set of fabric reinforced rings comprising one support ring, one sealing ring and a pressure energizing ring. It is a single acting piston seal.

The support ring or base ring is manufactured out of nitrile elastomer with high Shore A hardness and reinforced with impregnated cotton fabric layers for an optimal extrusion resistance.

The intermediate ring - the sealing ring - is a fabric reinforced nitrile elastomer with good resilience characteristics enabling the radial deflection under pressure load. Consequently the optimum sealing force is applied to the bore to be sealed.

The energiser or spreader ring is made of POM or PTFE. Its function is to ensure a uniform pre-load of the seal.

In some specific applications the energiser ring is made out of Acetal resin or Phenolic resin. Please contact our local B+S company for further details.

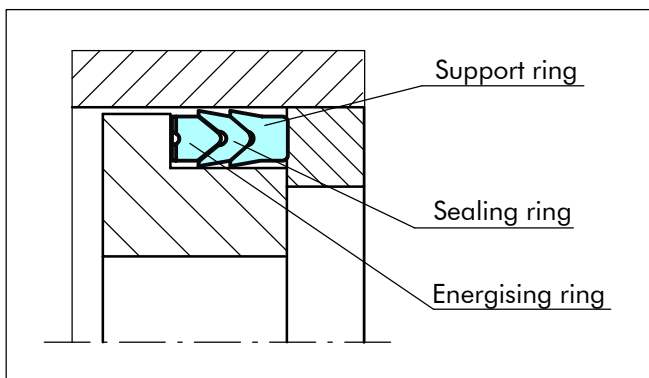

Figure 52 Veepac CH/G1

Advantages

- Exceptional wear resistance
- Pre-load adjustment capability
- Excellent behavior in harsh conditions

Application Examples

The Veepac seal is recommended for single acting or double acting (back to back installation) pistons in following applications:

- Mining equipment
- Excavator cylinders
- Steel mill cylinders
- Presses

Technical Data

Operating conditions:

Pressure: Up to 40 MPa

Velocity: Up to 0.5 m/s

Temperature: -30°C to +200°C, depending on material

Media: Mineral oil, water glycol, water emulsions

Important Note:

The above data are maximum values and cannot be used at the same time. e.g. the maximum operating speed depends on material type, pressure, temperature and gap value. Temperature range also dependent on medium.

Materials

The following material can be delivered:

Material Set Code	Temperature	Sealing Ring Material	Energiser/ Spreader Ring Material
N000C	-30 to +130°C	Cotton reinforced NBR	POM
V0P0C	-20 to +150°C	Cotton reinforced FKM	PTFE
V0P0A	-20 to +200°C	Aramidic fiber reinforced FKM	PTFE

Highlighted material is standard.

Ordering Example

For sealing element Veepac CH/G1 comprising 1 base ring and 1 Chevron element in cotton fabric reinforced NBR and the Spreader ring in POM.

Bore diameter: $D_N = 80.0 \text{ mm}$

Part No. from table XLIX: PCH0G0800

Material set-code

from material table above: N000C

Order No.	PC	H0	G	0800	-	N000C
Article sub group						
Series						
Execution Mark						
Bore diameter x 10						
Quality Index (Standard)						
Material code						
Poypac Ref. No.: CH 314236 G1						



Installation Recommendation, Type CH/G1

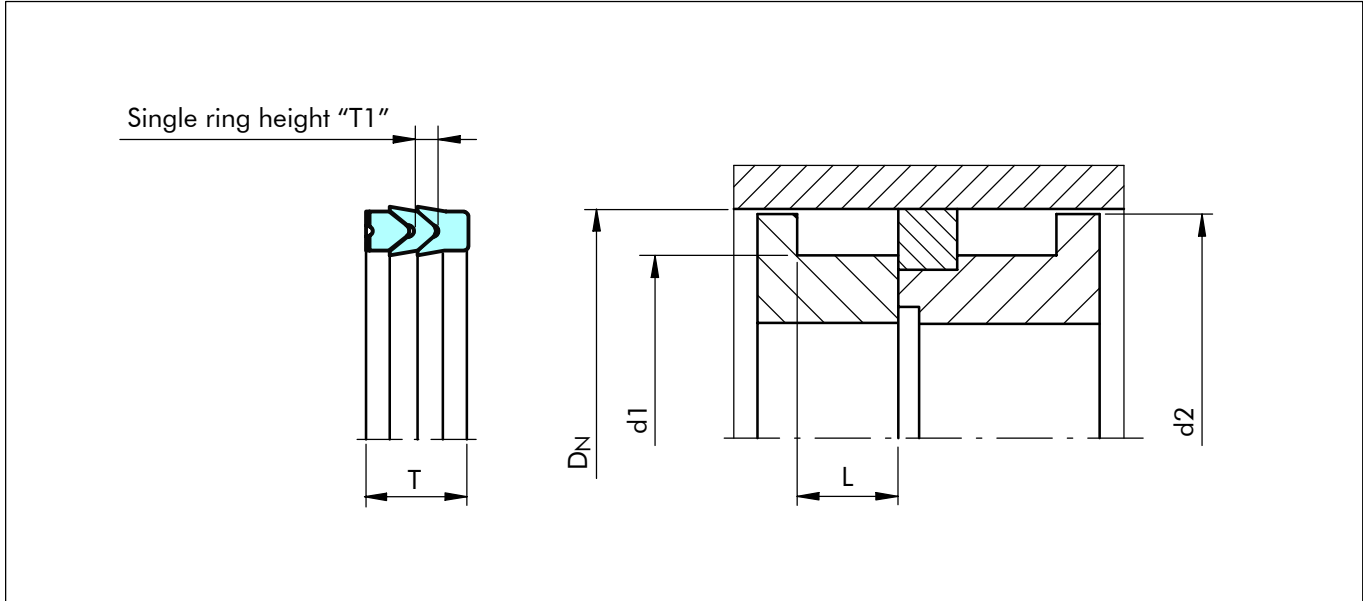

Figure 53 Installation drawing

Table XLIX Installation Dimensions / Part No.

Bore Dia.		Groove Dia.	Groove Width	Piston Dia.	Seal Width	Single Ring Height	Part No.	Polypac Ref. No.
DN	Tol.	d1 h11	L +0.3	d2 -0.3	T	T1		
40.0	H9/f8	25.0	11.5	39.0	11.0	3.2	PCH0G0400	CH 157098 G1
50.0		35.0	11.5	49.0	11.0	3.5	PCH0G0500	CH 196137 G1
55.0		40.0	11.5	54.0	11.0	2.9	PCH0G0550	CH 216157 G1
63.0		48.0	13.0	62.0	12.5	3.7	PCH0G0630	CH 248188 G1
65.0		50.0	11.5	64.0	11.0	3.9	PCH0G0650	CH 255196 G1
80.0		60.0	15.2	79.0	14.6	5.1	PCH0G0800	CH 314236 G1
100.0	H8/f8	80.0	21.2	99.0	20.6	5.0	PCH0G1000	CH 393314 G1
125.0	H8/f7	100.0	25.8	124.0	25.0	6.1	PCH0G1250	CH 492393 G1
140.0		115.0	25.8	139.0	25.0	8.0	PCH0G1400	CH 551452 G1
160.0		130.0	29.0	158.5	28.0	6.0	PCH0G1600	CH 629511 G1
180.0		150.0	31.5	178.5	30.5	9.9	PCH0G1800	CH 708590 G1
200.0		170.0	33.5	198.5	32.5	7.4	PCH0G2000	CH 787669 G1
240.0		210.0	33.5	238.5	32.5	10.2	PCH0G2400	CH 944826 G1
250.0		220.0	33.5	248.5	32.5	10.2	PCH0G2500	CH 984866 G1

Further size on Symmetric seal chapter.

POLYPAC[®] - SELEMASTER DSM

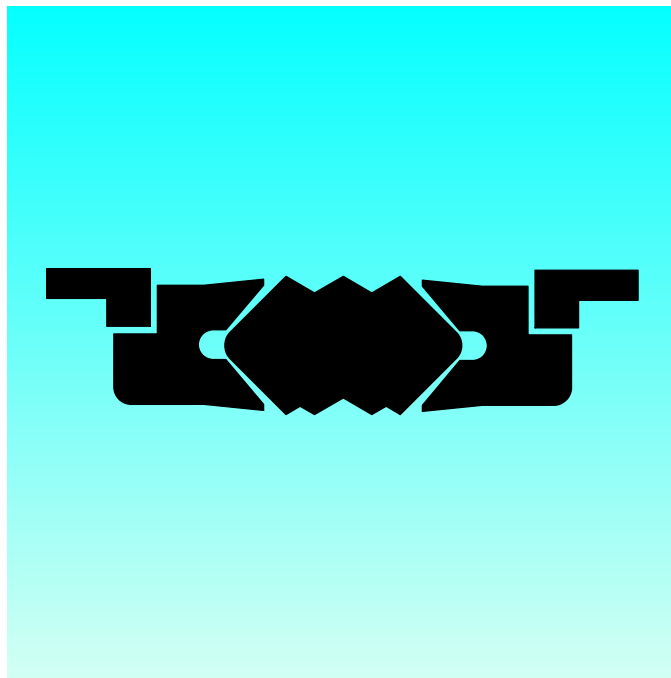

- Double Acting -

- Compact Piston Seal -

- Material -

- NBR + Fibre Reinforced NBR + POM -





Selemaster DSM

Description

The piston seal DSM range has been designed to meet the needs of hydraulic equipments operating at high pressures and subjected to severe loading and vibration conditions.

The main sealing element is manufactured in a highly compression set resistant nitrile. The most important quality of this element is the design of the multiple sealing lips for maximum sealing efficiency and end face configuration, which ensures that the selemaster can tolerate vibrations and severe misalignment.

The two support rings are made in cotton fabric reinforced nitrile elastomer; the "U" shape is energised when pressure is applied.

The last elements are the two guide rings manufactured in acetal resin which have also the function of anti-extrusion rings.

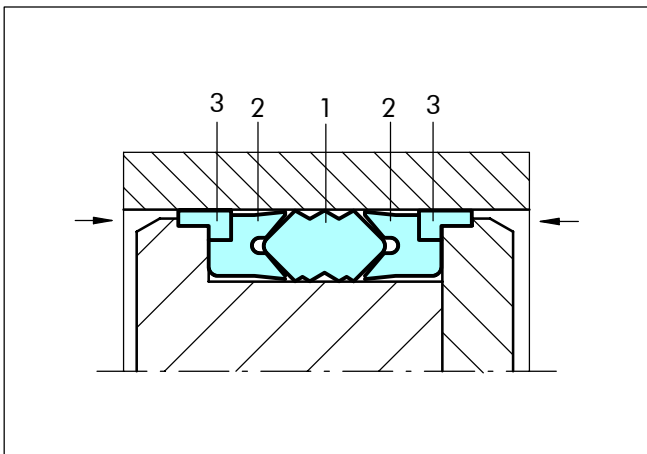

Figure 54 Selemaster design

- 1) Sealing element
- 2) Support ring
- 3) Guide ring

Advantages

- Effective sealing during vibration and shock loading
- High sealing efficiency
- Extrusion resistance at high pressure

Application Examples

- Earth-moving machines
- Excavators
- Lift platforms

Technical Data

Operating conditions

Pressure: Up to 70 MPa

Velocity: Up to 0.5 m/s

Temperature: -40°C to +130°C

Media: Hydraulic fluids
Mineral oil-based hydraulic fluids, water and water/ glycol emulsions

Groove type: Open

Important Note:

The above data are maximum values and cannot be used at the same time. e.g. the maximum operating speed depends on material type, pressure, temperature and gap value. Temperature range also dependent on medium.

Standard Material

- 1) Sealing element NBR 80
- 2) Support ring Cotton reinforced NBR
- 3) Guide ring POM

Ordering Example

Selemaster DSM

Bore diameter: $D_N = 70.0 \text{ mm}$

Groove diameter: $d = 50.0 \text{ mm}$

Groove width $E = 35.0 \text{ mm}$

Part No.(from table L): PCL000700

Material code: N8CO

Polypac Ref.: DSM 275196/1A

Order No.	PCL	0	00700	-	N8CO
Series No.					
Type (Standard)					
Bore diameter x 10					
Quality Index (see table)					
Material Set-code					



■ Installation Recommendation

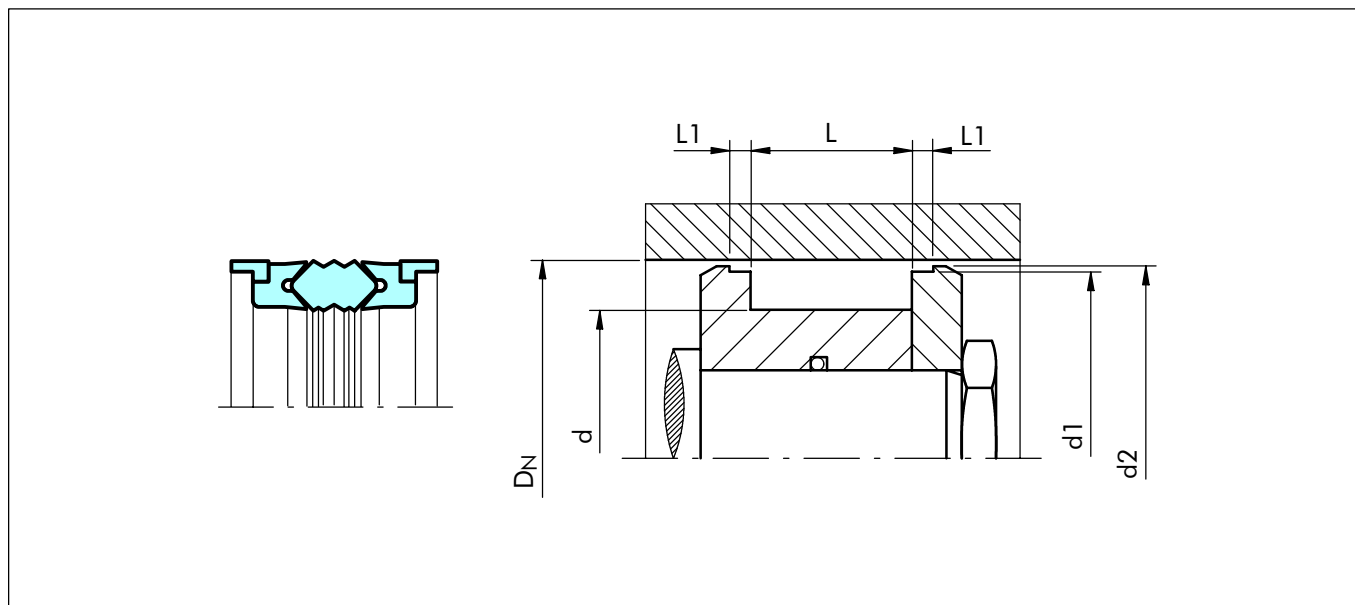

Figure 55 Installation drawing

Table L Installation Dimensions / Part No.

Bore Dia.	Groove Dia.	Groove Width		Diameter	Diameter		Part No.	Polypac Ref. No.
$D_N H11$	$d h11$	$L +0.2$	$L1 +0.1$	$d1 +/-0.05$	$d2 +/-0.07$			
45.00	29.00	32.00	6.35	38.80	42.80	^	PCL000450	DSM 177114/1A
50.00	34.00	32.00	6.35	43.77	47.80		PCL000500	DSM 196133/1A
55.00	40.00	32.00	6.35	48.77	52.80		PCL000550	DSM 216157/1A
60.00	44.00	32.00	6.35	53.80	57.80		PCL000600	DSM 236173/1A
63.00	47.00	32.00	6.35	56.74	60.80		PCL000630	DSM 248185/1A
63.50	47.62	31.75	6.35	57.25	61.30	^	PCL000635	DSM 250187/1A
65.00	49.00	32.00	6.35	58.70	62.80		PCL000650	DSM 255192/1A
70.00	50.00	35.00	9.52	62.62	67.50		PCL000700	DSM 275196/1A
75.00	55.00	35.00	9.52	67.70	72.50		PCL000750	DSM 295216/1A
80.00	60.00	35.00	9.52	72.62	77.50		PCL000800	DSM 314236/1A
80.00	64.00	32.00	9.52	72.62	77.50		PCL100800	DSM 314251/1A
85.00	65.00	35.00	9.52	77.62	82.50		PCL000850	DSM 334255/1A
90.00	70.00	35.00	9.52	82.58	87.80		PCL000900	DSM 354275/1A
90.00	74.00	32.00	9.52	82.87	87.80		PCL100900	DSM 354291/1A
92.07	73.02	34.92	9.52	84.66	89.60	^	PCL000921	DSM 362287/1A
95.25	76.20	34.92	9.52	87.86	92.80	^	PCL000953	DSM 375300/1A
95.00	75.00	35.00	9.52	87.60	92.50		PCL000950	DSM 374295/1A
100.00	80.00	35.00	9.52	92.60	97.50		PCL001000	DSM 393314/1A
101.60	82.55	34.92	9.52	94.20	99.10		PCL001016	DSM 400325/1A
105.00	85.00	35.00	9.52	97.60	102.50	^	PCL001050	DSM 413334/1A
110.00	85.00	45.00	12.70	101.82	107.30		PCL001100	DSM 433334/1A
110.00	90.00	35.00	9.52	102.70	107.50		PCL101100	DSM 433354/1A
114.30	88.90	44.45	12.70	106.12	111.60		PCL001143	DSM 450350/1A
115.00	90.00	45.00	12.70	106.82	112.30		PCL001150	DSM 452354/1A

^ Available upon request



Bore Dia.	Groove Dia.	Groove Width		Diameter		Part No.	Polypac Ref. No.
				d1 +/-0.05	d2 +/-0.07		
D _N H11	d h11	L +0.2	L1 +0.1				
120.00	95.00	45.00	12.70	111.82	117.30	PCL001200	DSM 472374/1A
120.00	100.00	35.00	9.52	112.80	117.50	PCL101200	DSM 472393/1A
125.00	100.00	45.00	12.70	116.82	122.30	PCL001250	DSM 492393/1A
127.00	101.60	44.45	12.70	118.80	124.30	PCL001270	DSM 500400/1A
130.00	105.00	45.00	12.70	121.82	127.30	PCL001300	DSM 511413/1A
130.00	110.00	35.00	9.52	122.70	127.30	PCL101300	DSM 511433/1A
135.00	110.00	45.00	12.70	126.82	132.30	PCL001350	DSM 531433/1A
139.70	114.30	44.45	12.70	131.47	137.00	PCL001397	DSM 550450/1A
140.00	115.00	45.00	12.70	131.72	137.30	PCL001400	DSM 551452/1A
140.00	120.00	35.00	9.52	132.70	137.30	PCL101400	DSM 551472/1A
145.00	120.00	45.00	12.70	136.72	142.30	PCL001450	DSM 570472/1A
150.00	125.00	45.00	12.70	141.72	147.30	PCL001500	DSM 590492/1A
152.40	127.00	44.45	12.70	144.15	149.70	PCL001524	DSM 600500/1A
160.00	135.00	45.00	12.70	151.72	157.10	PCL001600	DSM 629531/1A
165.00	135.00	45.00	12.70	158.00	162.10	PCL001650	DSM 649531/1A
170.00	140.00	45.00	12.70	163.00	167.90	PCL001700	DSM 669551/1A
177.80	152.40	44.45	12.70	169.55	175.10	PCL001778	DSM 700600/1A
180.00	155.00	45.00	12.70	171.60	177.10	PCL001800	DSM 708610/1A
185.00	160.00	45.00	12.70	176.72	182.10	PCL001850	DSM 728629/1A
190.00	165.00	45.00	12.70	181.72	187.10	PCL001900	DSM 748649/1A
200.00	175.00	45.00	12.70	191.72	197.10	PCL002000	DSM 787688/1A
210.00	185.00	45.00	12.70	201.60	207.10	PCL002100	DSM 826728/1A
220.00	195.00	45.00	12.70	211.60	217.10	PCL002200	DSM 866767/1A
230.00	205.00	45.00	12.70	221.72	227.10	PCL002300	DSM 905807/1A
240.00	215.00	45.00	12.70	231.72	237.10	PCL002400	DSM 944846/1A
250.00	225.00	45.00	12.70	241.72	247.10	PCL002500	DSM 984886/1A
260.00	235.00	45.00	12.70	251.72	257.10	PCL002600	DSM 1024925/1A
270.00	245.00	45.00	12.70	261.72	267.10	PCL002700	DSM 1062965/1A
280.00	255.00	45.00	12.70	271.72	277.10	PCL002800	DSM 11021004/1A
290.00	265.00	45.00	12.70	281.72	287.10	PCL002900	DSM 11411043/1A
300.00	275.00	45.00	12.70	291.72	297.10	PCL003000	DSM 11811082/1A
360.00	335.00	44.50	12.70	351.76	357.30	PCL003600	DSM 14171318/1A

^ Available upon request



NON STANDARD SEALS



- Available upon Request -
- Old Series -
- Special Series -





Sealing Parts RSE/W

Single acting piston seal for dynamic applications. Installed in similar groove as B/NWO. The sealing element consist in a polyurethane U Cup and an L-shaped Back-up/guide ring.

Diameter Range mm	Pressure Range MPa	Temperature Range °C	Velocity m/s
32 - 120	Up to 25	-30 to +80	Up to 0.5

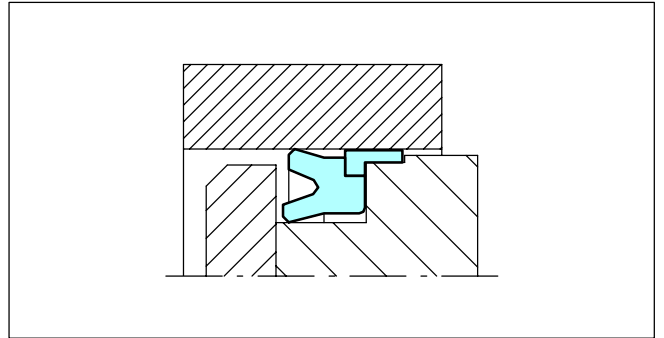

Sealing Parts RSE/W/AR

Sealing element identical to RSE/W with an additional retaining ring in front to allow easier installation.

Diameter Range mm	Pressure Range MPa	Temperature Range °C	Velocity m/s
32 - 120	Up to 25	-30 to +80	Up to 0.5

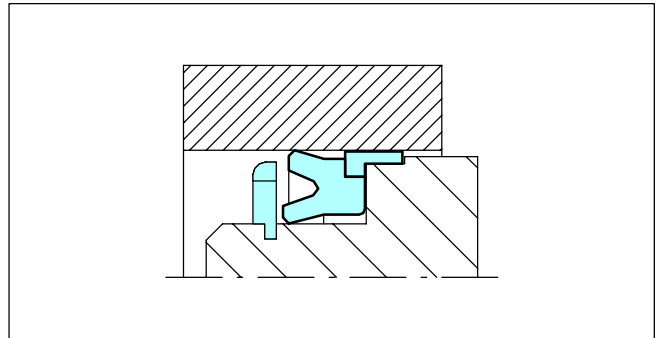

Polypac® D11W

Double acting piston seal for dynamic applications. Installed in open grooves. The NBR sealing element is supported at both sides by vulcanised cotton fabric reinforced rings with additional guide rings. High sealing efficiency and high wear resistance.

Diameter Range mm	Pressure Range MPa	Temperature Range °C	Velocity m/s
25 - 300	Up to 50	-30 to +200	Up to 0.5

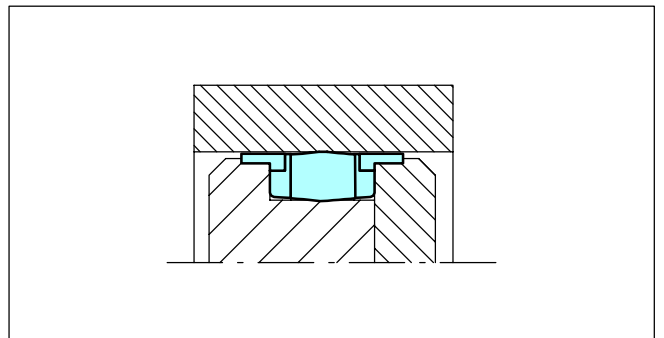

Polypac® DS - DS/NEO

Single acting piston U Ring for dynamic applications. Installed in open grooves. The U shaped sealing element is made out of cotton fabric reinforced NBR and provide with a NBR energiser ring and an additional POM back up ring can be integrated DS/NEO. High sealing efficiency and high wear resistance.

Diameter Range mm	Pressure Range MPa	Temperature Range °C	Velocity m/s
25 - 300	Up to 70 (DS/NEO)	-30 to +130	Up to 0.5

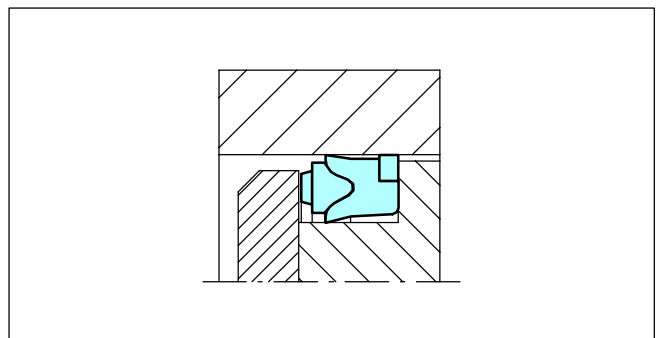



Non Standard Piston Seals

Polypac® URS - URFU

Single acting piston U ring. installed in open grooves. The cotton reinforced NBR provides a high degree of stability and long service life.

Diameter Range mm	Pressure Range MPa	Temperature Range °C	Velocity m/s
16 - 340	Up to 40	-30 to +130	Up to 0.5

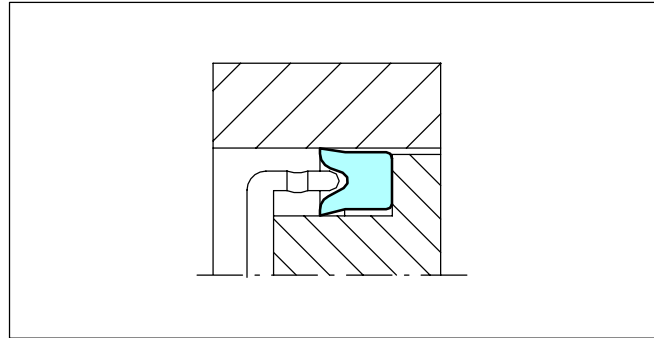

Polypac® B/NWO

Single acting piston seal for dynamic applications. Installed in open grooves. The nitrile sealing element is supported by a vulcanised cotton fabric reinforced ring with additional guide rings. High sealing efficiency and high wear resistance.

Diameter Range mm	Pressure Range MPa	Temperature Range °C	Velocity m/s
25 - 300	Up to 50	-30 to +200	Up to 0.5

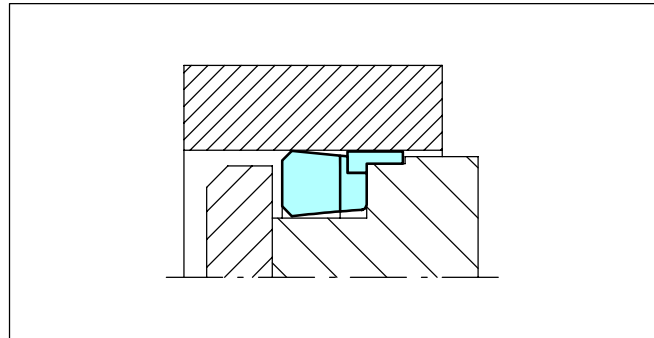

Polypac® B/NWO - KR

Same sealing element as B/NWO with an additional retaining ring in front to allow easier installation.

Diameter Range mm	Pressure Range MPa	Temperature Range °C	Velocity m/s
25 - 300	Up to 50	-30 to +200	Up to 0.5

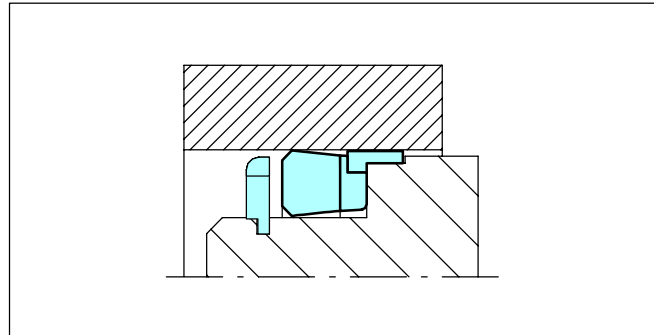

Polypac® B/NEO

Single acting piston seal for dynamic applications. Installed in open grooves. The nitrile sealing element is supported by a vulcanised cotton fabric reinforced ring with additional anti-extrusion ring. High sealing efficiency and wear resistance.

Diameter Range mm	Pressure Range MPa	Temperature Range °C	Velocity m/s
30 - 65	Up to 40	-30 to +130	Up to 0.5

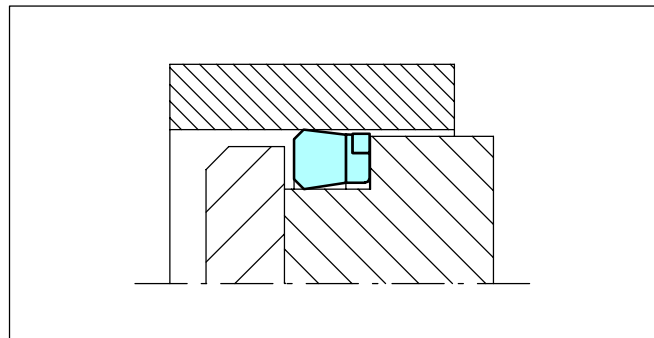



Turcon® VL Seal™

Single acting O-Ring energised Piston Seal for dynamic applications. Installed in closed grooves. High seal efficiency and high flexibility also under adverse temperature and with radial displacement. Installed in standard O-Ring grooves.

Diameter Range mm	Pressure Range MPa	Temperature Range °C	Velocity m/s
14 - 2700	Up to 60	-45 to +200	Up to 15

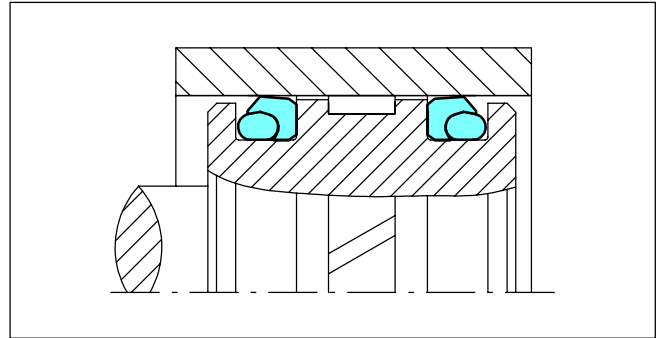

Turcon® Variseal® W

Single acting piston seal energised by a special helical spring. Its main advantage lies in its low friction and constant preloading force over a relatively large deformation range.

The Turcon® Variseal® W is used wherever friction has to be kept within a narrow tolerance zone.

Diameter Range mm	Pressure Range MPa	Temperature Range °C	Velocity m/s
8 - 2700	Up to 40	-70 to +260	Up to 15

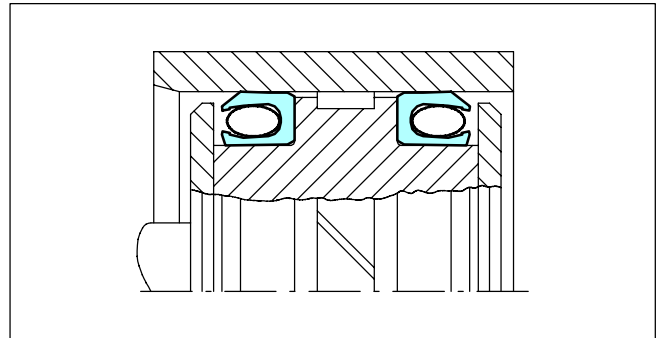

Turcon® Variseal® M2 CR

Single acting sealing element comprising a U-shaped Turcon® ring and a Stainless Steel energising V spring. Low friction with no Stick-slip, minimal break out force and high wear resistance. Resistant to most liquids and chemicals. Unlimited shelf life.

With integrated back up rings in material Zurcon® Z43 for higher pressures or larger gaps.

Diameter Range mm	Pressure Range MPa	Temperature Range °C	Velocity m/s
8 - 300	Up to 100	-45 to +260	Up to 5

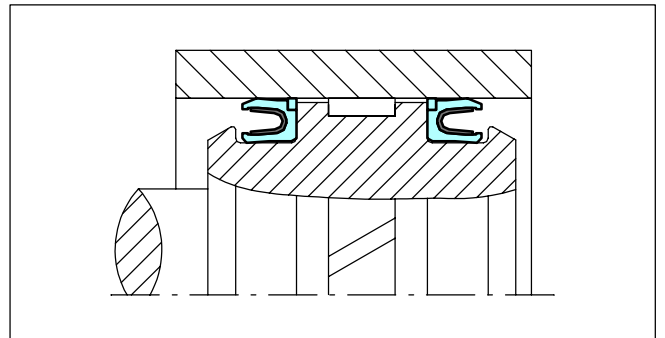

Turcon® Glyd Ring® CR

Double acting O Ring energised Piston Seal for dynamic applications. Installed in closed grooves including grooves to ISO 7425 as piston Turcon® Glyd Ring®. Low friction with no Stick-slip, minimal break out force and high wear resistance with integrated back up rings for higher pressures or larger gaps.

Diameter Range mm	Pressure Range MPa	Temperature Range °C	Velocity m/s
8 - 2700	Up to 100	-45 to +200	Up to 5

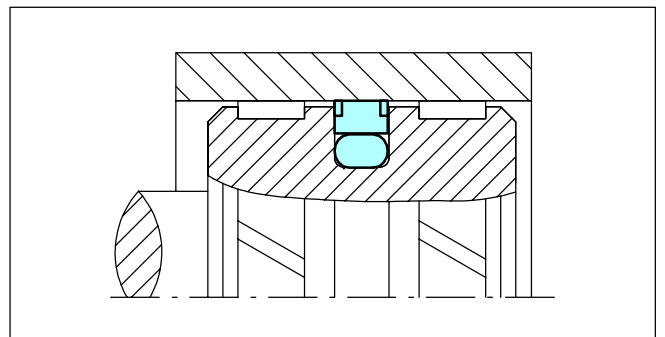

Important Note: In the case of unpressurized applications in temperatures below 0°C please contact our application engineers for assistance !



Non Standard Piston Seals

Turcon® Glyd Ring® Hz

Double acting O Ring energised Piston Seal for dynamic applications. Special design on the sealing based on two face to face Stepseal® profiles. The seal width is close to groove width to avoid axial movements.

The Glyd Ring® Hz is particularly dedicated to short strokes and high frequency applications. Installed in grooves according to ISO 7425 as piston Turcon® Glyd Ring®.

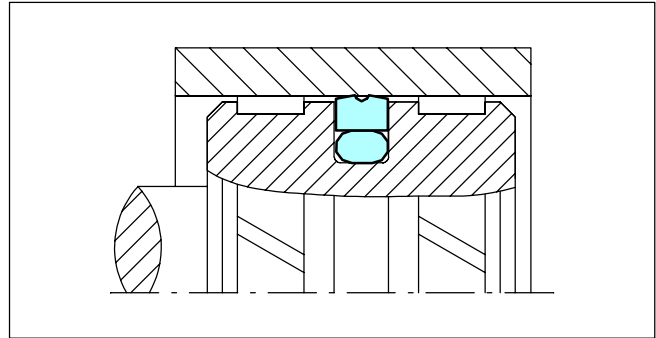

Diameter Range mm	Pressure Range MPa	Temperature Range °C	Velocity m/s
8 - 2700	Up to 40	-45 to +200	Up to 15

Captive Turcon® Glyd Ring®

For special applications where the Glyd Ring® has to slide across dimensional changes (e.g. go from a small diameter with sealing efficiency over the seal to a larger diameter with no sealing efficiency or vice versa).

In such applications Standard Glyd Ring® would be pressed out of the groove.

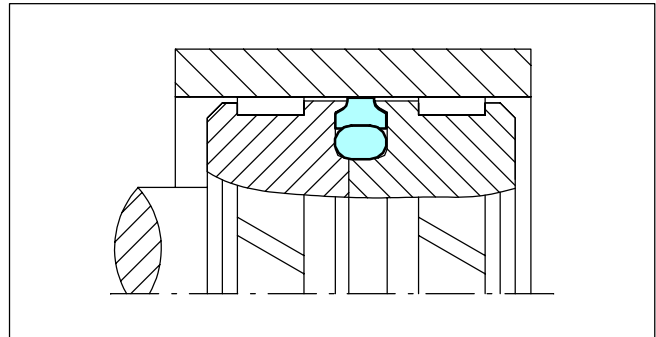

Diameter Range mm	Pressure Range MPa	Temperature Range °C	Velocity m/s
8 - 2700	Up to 60	-45 to +200	Up to 15

Turcon® Stepseal® CR

Single acting O-Ring energised Piston Seal for dynamic applications. Installed in closed grooves including grooves acc. ISO 7425. High sealing efficiency, low friction with no Stick-slip, minimal break out force and high wear resistance.

With integrated Back-up rings for higher pressures or larger gaps.

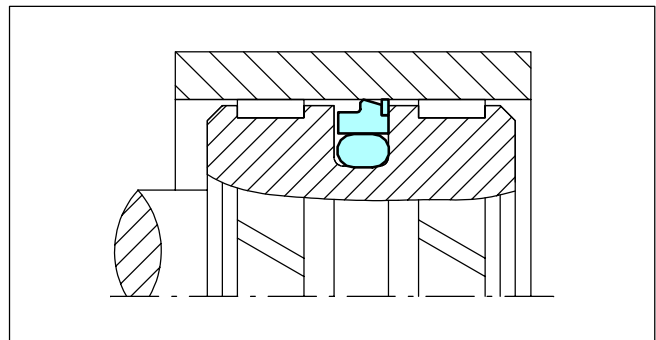

Diameter Range mm	Pressure Range MPa	Temperature Range °C	Velocity m/s
8 - 2700	Up to 100	-45 to +200	Up to 5

Important Note: In the case of unpressurized applications in temperatures below 0°C please contact our application engineers for assistance !