

PNEUMATIC SPECIALIST CERTIFICATION

Manual Including Study Guide, Solutions, & Pre-Tests



Manual # 401 - 7/02

FLUID POWER CERTIFICATION BOARD

FLUID POWER SOCIETY

The International Organization for Fluid Power and Motion Control Professionals

General Pneumatic Safety Guidelines

Compressed air can be dangerous unless precautions are taken. These precautions are mostly common sense, but are nonetheless worth listing in places where compressed air is used. Consideration should be given to placing these, or similar, guidelines in a prominent place.

- Only pressure vessels built to a national or international standard should be used for air receivers.
- It is essential that a check valve and shut-off valve are fitted in the delivery line when the compressor is to be coupled in parallel with another compressor or connected to an existing air supply system. In such cases, a safety valve must be provided upstream of the valves, unless one is already fitted on the compressor.
- Do not use frayed, damaged or deteriorated hoses. Always store hoses properly and away from heat sources or direct sunlight. A hose failure can cause serious injury.
- Use only the correct type and size of hose end fittings and connections. Use heavy duty clamps made especially for compressed air systems.
- Use eye protection. If using compressed air for cleaning down equipment, do so with extreme caution. Take care not to blow dirt at people or into machinery.
- When blowing through a hose or air line, ensure that the open end is held securely. A free end will whip and can cause injury. Open the supply air cock carefully and ensure that any ejected particles will be restrained. A blocked hose can become a compressed air gun.
- Never apply compressed air to the skin or direct it at a person. Even air at a pressure of 15 psi (1 bar) can cause serious injury. Never use a compressed air hose to clean dirt from your clothing.
- Do not use air directly from a compressor for breathing purposes, for example charging air cylinders, unless the system has been specifically designed for such purpose and suitable breathing air filters and regulators are in place.

Precautions during start-up:

- If an isolating or check valve is fitted in the compressor discharge, it is essential to check that an adequate safety valve is in place between this isolating valve and the compressor and that the isolating valve is open.
- Before starting any machinery, all protective guards should be in position and be secure.
- On the initial start-up, the direction of rotation of an compressor must be checked. Severe damage may be caused if the compressor is allowed to run in the wrong direction.
- Ensure that a machine can not be started inadvertently. Place a warning notice at the lock-out.
- Do not weld or in anyway modify any pressure vessel.
- Isolating valves should be of the self venting type and designed to be locking in the "off" position so that air pressure cannot be applied inadvertently while the machine is being worked on.
- Exposure to excessive noise can damage hearing. Wear ear protection.
- Noise reducing mufflers can be fitted to machines to lessen the noise health hazard.
- A concentration of oil mist in the air from system lubricators can be hazardous.
- Check hoses and couplings daily before use. Use only hoses designed to handle compressed air. Provide all hose couplings with a positive locking device. Secure Chicago-type fittings together with wire or clips.
- Never crimp, couple, or uncouple pressurized hose. Shut off valves and bleed down pressure.
- When using compressed air for cleaning purposes, ensure pressure does not exceed 30 psi. Use goggles or a face shield over approved safety glasses for this application. Do not use compressed air to clean dust or debris off your body.
- Make sure all hoses exceeding 1/2 inch ID have a safety device at the source of supply or branch line to reduce the pressure in case of hose failure.

FLUID POWER SOCIETY

Headquarters: 3245 Freemansburg Avenue, Palmer, PA 18045-7118

Phone: 610-923-0386 or 800-303-8520 • Fax: 610-923-0389

E-mail: AskUs@IFPS.org • Web: <http://www.IFPS.org>

Fax-On-Demand: 800-214-2958

Pneumatic Specialist Certification Study Guide

Foreword

This study guide has been written for candidates who wish to prepare for the Pneumatic Specialist Certification exam. It contains numbered outcomes, from which test items on the exam were written, a discussion of the related subject matter with illustrations, references for additional study, and review questions. While the study guide covers the basics of the exam, additional reading of the references is recommended.

The outcomes and review questions are intended to focus attention on a representative sample of the subject matter addressed by the exam. This does not mean that the study guide will teach the test. Rather, the study guide is to be used as a self-study course, or an instructional course if a Review Training Seminar is available, to address representative subject matter covered by the exam. Both the exam questions and review questions have been written from the same outcomes. To this extent, if the candidate understands the subject matter given here and can answer the review questions correctly, he or she should be prepared to take the Pneumatic Specialist Certification exam.

The U.S. Government Federal Occupational Code defines the special skills and knowledge required by Fluid Power Specialists as follows:

“Fluid Power applications engineer, Fluid Power sales representative, Fluid Power consultant. Analyzes power transmission and motion control situations and designs appropriate hydraulic or pneumatic systems to perform required tasks. Selects appropriate components, designs or modifies complete circuit, prepares Bills of Materials, and specifies fluids, prime movers and appropriate fluid conductors. Troubleshoots non-performing systems to determine necessary repairs. Also, designs appropriate instrumentation and control systems (hydraulic, pneumatic, and electronic) for industrial and mobile machinery. May become involved in sales activities, product warranty claims, and evaluation of prototype machinery.

May become involved in instructional activities for Fluid Power Technicians and Fluid Power Mechanics concerning principles of hydraulics and pneumatics as well as the operation and maintenance of particular machines.”

Based upon this description, the Pneumatic Specialist must demonstrate expertise in the skill areas, as well as knowledge, comprehension and application of various principles addressed in this study guide. The study guide follows a simple format that uses outcomes and review questions to focus attention on what is important. If a candidate can master the outcomes by understanding the technical information and answering the review questions correctly, he or she should be able to achieve a passing score on the examination, and the honor of becoming an Pneumatic Specialist.

A word about pressure and flow units used in this study guide is in order:

bar = 14.5 PSIG.

psig = Pounds per square inch gauge (pressure above atmospheric).

psia = Pounds per square inch absolute (gauge pressure plus 14.7 psia).

Free Air = Air at atmospheric conditions at any specific location. Typically, NOT at standard conditions (free air, at the compressor intake).

cfm = Flow rate in cubic feet per minute, at a given pressure (can be free or compressed).

scfm = Flow rate in standard cubic feet per minute at standard conditions (14.7 psia, 68°F, 36% relative humidity).

Note that scfm is always stated at 0-psig (14.7 - psia), but cfm may be stated as free air or compressed to a stated pressure.

Copyright © 2002, 1999, 1994 by Fluid Power Society. All rights reserved. No part of this book may be reproduced or used in any form without permission in writing from the publisher. Address information to Fluid Power Society, 3245 Freemansburg Avenue, Palmer, PA 18045.

Disclaimer

The Fluid Power Society (FPS) has attempted to verify the formulas, calculations, and information contained in this publication. However, the FPS disclaims any warranty, expressed or implied, of the fitness of any circuit, data, or information discussed in this publication for a particular application. Whenever the reader intends to use any of the information contained in this publication, the reader should independently verify that the information is valid and applicable to the application. The FPS neither endorses/recommends, nor disapproves of, any brand name or particular product use by virtue of its inclusion in this publication. The FPS has obtained the data contained within this publication from generally accepted engineering texts, catalog data from various manufacturers, and other sources. The FPS does not warrant any of this information in its application to a particular application. The FPS welcomes additional data for use in future revisions to this and other FPS publications.

Credits

The Fluid Power Society wishes to thank several professionals who developed and reviewed this manuscript. The guidance and support of this project has helped advance our industry and provided another benchmark for Fluid Power.

Principal Development Coordinator
John Groot, The Knotts Company

Development Team

Richard Eckhard, The Knotts Company
Clayton Fryer, Norgren
Greg Gordon, Ohio State University
Ray Hanley, Fluid Power Society
Fred Heimall, The Knotts Company
Lou Honary, University of Northern Iowa
Mike Joannides, Henry Ford Community College
Robert Kirk, Humphrey Fluid Power Limited
Terry Ward, The Knotts Company

Certification Review Committee

Don DeRose, Fluid Power Society
Jim Fischer, Minnesota West Comm. & Tech. College
Clayton Fryer, Norgren
John Groot, The Knotts Company
Ray Hanley, Fluid Power Society
Ernie Parker, Hennepin Technical College
Paul Prass, Fluid Power Society
John Seim, Alexandria Technical College
Bob Sheaf, Certified Fluid Consultants
Jim Sullivan, Southern Illinois University
Tom Wanke, Milwaukee School of Engineering
Terry Ward, The Knotts Company
Robert Yund, Hennipin Technical College

Administrative Coordination

Kerry Collins, Fluid Power Society

Design and Layout

Jessica Bieber, Innovative Designs & Publishing, Inc.
Kylene Huffert, Innovative Designs & Publishing, Inc.
Carl Thaxton, Certified Fluid Consultants

Contents

Load and Motion Analysis

| Outcome | Page |
|---|------|
| 1. Solves formulas for torque, speed and horsepower of an air motor connected through a reduction system to a conveyor. | 11 |
| 2. Solves for the reaction force on a cylinder rod bearing from the stroke, mechanical advantage and side load on the rod | 14 |
| 3. Computes the bore diameter and pressure for a cylinder to move loads with a friction factor (Coefficient of Friction) | 16 |
| 4. Computes the cylinder bore diameter and pressure to operate a gripper through a mechanical advantage. | 19 |
| 5. Computes the shear strength of fixture attachments to retain rodless cylinder couplings under load | 20 |

System Analysis and Troubleshooting

| | |
|---|----|
| 6. Computes the air cylinder pressure required to support jib-boom loads | 21 |
| 7. Solves for the pressure and suction area to provide a required lifting force using vacuum cups. | 22 |
| 8. Converts pressure readings between inches of water and inches of mercury (in-Hg.) | 23 |
| 9. Uses manufacturer's graphs and formulas to determine cfm requirements for an air motor | 24 |
| 10. Predicts the operation of a pneumatic circuit from the placement of components in the circuit. | 26 |
| 11. Predicts the operation of a pneumatic system by tracing the path of air flowing through various circuits when various commands are given | 29 |
| 12. Predicts the operation of a pneumatic system by tracing a malfunction to a faulty component | 31 |
| 13. Identifies the most likely fault in a pneumatic circuit from symptoms and operational characteristics | 32 |
| 14. Predicts the operation of a pneumatic system when special commands are given (System Shutdown, Emergency Stop, Interrupted Air, Error Signal) | 33 |

Contents

System Design

| | |
|---|----|
| 15. Selects the appropriate solution to control air cylinder velocity. | 35 |
| 16. Selects the location of various components in a circuit to achieve cylinder sequence functions. | 36 |
| 17. Selects the location of various components in a circuit to achieve a deceleration function | 38 |
| 18. Selects conductor sizes from application charts given pressure, flow delivery and line length | 39 |
| 19. Uses formulas to size air receivers to perform various functions. | 40 |
| 20. Selects input components to achieve a desired operation in a pneumatic circuit. | 41 |
| 21. Identifies the most and least important safety considerations in the design of an air circuit | 42 |

Component Application

| | |
|---|----|
| 22. Computes the pressure to extend a loaded cylinder operating on an incline | 44 |
| 23. Recognizes the advantages and disadvantages of single-acting and double-acting cylinders | 45 |
| 24. Computes the cfm of air flow to power an air cylinder. | 47 |
| 25. Computes the cylinder bore diameter for a load attached to a cylinder through a system of levers and pulleys | 48 |
| 26. Calculates the scfm of air flow to power a single rod cylinder with extension and retraction forces and cylinder times specified | 50 |
| 27. Calculates the oil flow rate and pressure from a pneumatic intensifier. | 52 |
| 28. Calculates the torque output from a rack and pinion gear mechanism driven by two air cylinders | 54 |
| 29. Calculates the kinetic energy required to stop a load with a shock absorber | 55 |
| 30. Recognizes the characteristics of stop tubes and cushioning devices. | 57 |
| 31. Associates the cylinder designs with their applications | 58 |
| 32. Calculates the C_v for an air valve from pressure, flow and temperature conditions. | 60 |
| 33. Recognizes that the critical (sonic) velocity through an orifice is reached when the downstream pressure is 53% of the up stream pressure, and at the critical velocity, increasing the pressure drop across the orifice will not increase air flow | 62 |
| 34. Calculates the C_v to size a directional control (power) valve for an air motor. | 63 |

Contents

Air Compression and Preparation

| | |
|---|----|
| 35. Calculates the required compressor delivery capacity from the system demand, pressure and duty cycle..... | 64 |
| 36. Associates pneumatic components with their functions | 66 |
| 37. Identifies characteristics of air filter elements | 68 |
| 38. Recognizes the application characteristics of pneumatic components | 70 |
| 39. Recognizes the operational characteristics of relieving and non-relieving pressure regulators | 72 |
| 40. Recognizes the operational characteristics of various types of vacuum generators | 74 |

Control Components and Systems

| | |
|---|----|
| 41. Computes the operational characteristics of a position feedback circuit | 76 |
| 42. Uses Ohm's Law and Kirchhoff's Law to solve series-parallel circuits for voltage, current and resistance | 78 |
| 43. Computes the voltage output signal from the operational characteristics of a strain gauge | 79 |
| 44. Identifies probable causes of pneumatic circuit failure from symptoms, sequence of circuit operations, circuit drawing and electrical schematic | 80 |
| 45. Applies Ohm's Law and Kirchhoff's Law to solenoid electrical circuits | 82 |
| 46. Determines the cycle characteristics for a pulse width modulated (PWM) pressure control valve | 83 |
| 47. Analyzes logic control circuits for an output signal | 84 |
| 48. Computes the current output from a pressure transducer signal and transducer characteristics (also see Outcome 43) | 86 |
| 49. Computes the resolution for digital linear transducers from the signal input characteristics | 87 |
| 50. Matches appropriate wiring arrangements between PLC's and directional control valves | 88 |

Figures

| | <u>Page</u> |
|--|-------------|
| Fig. 1. Air motor drive through a reduction system | 11 |
| Fig. 2. Torque..... | 12 |
| Fig. 3. Reaction Force on a cylinder rod..... | 14 |
| Fig. 4. “First Class”, “Second Class” and “Third Class” Levers | 14 |
| Fig. 5. Coefficient of friction calculation | 16 |
| Fig. 6. Trigonometric solutions to right triangles | 17 |
| Fig. 7. Forces of a load on an incline | 17 |
| Fig. 8. Up incline forces | 18 |
| Fig. 9. Down incline forces | 18 |
| Fig. 10. Scissor gripper | 19 |
| Fig. 11. Scissor gripper forces..... | 19 |
| Fig. 12. Rodless cylinder with magnetic coupling | 20 |
| Fig. 13. Jib boom..... | 21 |
| Fig. 14. Air motor graphs | 24 |
| Fig. 15. Single-acting cylinder circuit..... | 26 |
| Fig. 16. Working, signal output, signal processing and signal input components | 27 |
| Fig. 17. Time delay (one-shot) circuit..... | 27 |
| Fig. 18. Air circuit with three cylinders | 29 |
| Fig. 19. Velocity control for an air cylinder | 35 |
| Fig. 20. Signal processing components to control a cylinder circuit | 36 |
| Fig. 21. Two cylinder sequencing circuit | 37 |
| Fig. 22. Pneumatic velocity control circuit..... | 38 |
| Fig. 23. Signal processing components for Review 17.1 | 38 |
| Table 1. Maximum recommended air flow through Schedule 40 pipe | 39 |
| Fig. 24. Two cylinder air circuit | 41 |
| Fig. 25. Two-hand interlock circuit..... | 42 |
| Fig. 26. Two-hand, pilot operated interlock safety circuit | 43 |
| Fig. 27. Two-hand anti-tie-down interlock circuit with sealed timing module..... | 43 |
| Fig. 28. Friction load being moved up an incline by an air cylinder | 44 |
| Fig. 29. Single-acting cylinder..... | 45 |

Figures

| | | |
|----------|--|----|
| Fig. 30. | Double-acting cylinder | 45 |
| Fig. 31. | Applications of pneumatic cylinders using First, Second and Third Class Levers | 48 |
| Fig. 32. | Web tensioning system applying lever and pulley principles | 48 |
| Fig. 33. | Jib boom lever | 49 |
| Fig. 34. | Air-oil intensifier | 52 |
| Fig. 35. | Rack and pinion torque motor | 54 |
| Fig. 36. | Kinetic energy of a rolling object | 55 |
| Fig. 37. | Air-oil coupled cylinder | 57 |
| Fig. 38. | Typical air cylinder mounting arrangements | 58 |
| Fig. 39. | Guided shaft cylinder mounting | 58 |
| Fig. 40. | Compressor mounted on a receiver | 66 |
| Fig. 41. | Two-stage compressor with intercooler | 67 |
| Fig. 42. | Filter for compressed air | 68 |
| Fig. 43. | Typical “bang-bang” air circuit | 70 |
| Fig. 44. | Quick exhaust valve | 70 |
| Fig. 45. | Pressure regulator | 72 |
| Fig. 46. | Basic barometer measuring atmospheric pressure | 74 |
| Fig. 47. | Venturi vacuum pump principle | 75 |
| Fig. 48. | Linear resistive transducer (LRT) circuit | 76 |
| Fig. 49. | Position feedback cylinder circuit | 76 |
| Fig. 50. | Voltage drop resistance circuit | 78 |
| Fig. 51. | Four resistor strain gauge bridge circuit | 79 |
| Fig. 52. | Pneumatic circuit with electrical controls | 80 |
| Fig. 53. | Resistance calculation circuit | 82 |
| Fig. 54. | Pulse width modulation (PWM) signal | 83 |
| Fig. 55. | Basic logic functions | 84 |
| Fig. 56. | Timing-in circuit | 85 |
| Fig. 57. | Logic circuit | 85 |
| Fig. 58. | Block diagram of PLC components | 88 |

Reference Equations

| FPS Pneumatic Specialist Certification | | | |
|---|--------|---|---|
| Equations | Page # | Equation | Equation |
| Eq. #1 | 11 | Speed Ratio = Output Shaft Speed _{rpm} /Input Shaft Speed _{rpm} | SR = OS / IS |
| Eq. #2 | 12 | Torque _{lb-in} = Force _{lbs} x Radius _{in} | T = F x R |
| Eq. #3 | 12 | Work _{ft-lbs} = Force _{lbs} x Distance _{ft} | W = F x D |
| Eq. #4 | 13 | Power = (Force _{lbs} x Distance _{ft}) / Time _{seconds or minutes} | P = (F x D) / t |
| Eq. #5 | 12 | Horsepower = (Speed _{rpm} x Torque _{lb-ft}) / 5252 | HP = (N x T) / 5252 |
| | | Horsepower = (Speed _{rpm} x Torque _{lb-in}) / 63025 | HP = (N x T) / 63025 |
| | | Horsepower = (Speed _{rpm} x Torque _{N-m}) / 7124 | HP = (N x T) / 7124 |
| | | 1hp = 746 watts = 746 N-m/sec = 550 lb-ft/sec | |
| Eq. #6 | 14 | F ₁ x L ₁ = F ₂ x L ₂ | |
| Eq. #7 | 14 | F ₁ / F ₂ = L ₂ / L ₁ | |
| Eq. #8 | 15 | Mechanical Advantage = Total Rod Length _{in} /Supported Rod Length _{in} | MA = TRL / SRL |
| | | Using the Second Class Lever Formula: | MA = L ₁ / L ₂ |
| Eq. #9 | 15 | Reaction Force _{lbs} = Mechanical Advantage x Side Load _{lbs} | RF = MA x SL |
| Eq. #10 | 16 | Horizontal Friction Force _{lbs} = Coefficient of Friction x Load _{lbs} | HFF = C _f x L |
| Eq. #11 | 17 | Total Incline Force _{lbs} = | |
| | | (Coefficient of Friction x Load _{lbs} x Cos θ) + (Sin θ x Load _{lbs}) | TIF = (C _f x L x Cos θ) + (Sin θ x L) |
| Eq. #12 | 22 | 29.92 in-Hg = -14.7 psig = 0 psia | |
| Eq. #13 | 22 | Pressure _{psig} = Pressure Drop _{in-Hg} x -0.4912 psig/in-Hg | PSIG = PD x -0.4912 |
| Eq. #14 | 23 | Pressure _{ft-water} = Pressure _{in-Hg} x 1.133 | ft-H ₂ O = in-Hg x 1.133 |
| Eq. #15 | 40 | Time _{min} = | |
| | | [Volume _{cu-ft} x (Max-Pressure _{psig} -Min-Pressure _{psig})] / (14.7 x Q _{scfm}) | T = [V x (P _{max} - P _{min})] / (14.7 x Q) |
| | | To convert cubic-feet to gallons, multiply by 7.48 | |
| Eq. #16 | 47 | CFM _{SA} = | CFM _{SA} = (A x S x cpm) / 1728 |
| | | (Piston Area _{sq-in} x Stroke _{in} x Cycle Rate _{strokes/min}) / 1728 cu-in/cu-ft | |
| | | CFM _{DA} = | CFM _{DA} = (A x S x 2 x cpm) / 1728 |
| | | (Piston Area _{sq-in} x Stroke _{in} x 2 x Cycle Rate _{strokes/min}) / 1728 cu-in/cu-ft | |

Reference Equations

| FPS Pneumatic Specialist Certification | | | |
|---|--------|--|---|
| Equations | Page # | Equation | Equation |
| Eq. #17 | 47 | Compression Ratio = (Pressure _{psig} + 14.7) / 14.7 | CR = (psig + 14.7) / 14.7 |
| Eq. #18 | 47 | SCFM = CFM x Compression Ratio | SCFM = CFM x CR |
| Eq. #19 | 51 | Average Velocity _{ft/min} = (Stroke _{in} x 5) / (retraction or extension time _{sec} + dwell time _{sec}) | AV = (S x 5) / t |
| Eq. #20 | 51 | CFM = (Area _{sq-in} x Velocity _{ft/min}) / 144 sq-in/sq-ft | CFM = (A x V) / 144 |
| Eq. #21 | 52 | Air Pressure _{psig} x Air Area _{sq-in} = Oil Pressure _{psig} x Oil Area _{sq-in} | P Air x A Air = P Oil x A Oil |
| Eq. #22 | 52 | Q _{gpm} = (Area _{sq-in} x Stroke _{in} x Strokes/Minute) / 231 cu-in/gal | Q = (A x S x SPM) / 231 |
| Eq. #23 | 54 | T _{lb-in} = Pressure _{psig} x Area _{sq-in} x (PD _{in} /2) x # of Effective Cylinders | T = P x A x (PD/2) x #C |
| Eq. #24 | 55 | KE _{ft-lbs} = (W _{lbs} x v _t ²) / 2g g = 32.2 ft/sec ² | KE = (W x v _t ²) / 64.4 |
| Eq. #25 | 55 | V _{terminal} = 2D _{ft} / t _{sec} | v _t = 2D / t |
| Eq. #26 | 60 | C _v = Flow _{scfm} / 22.67 √ T _{Rankine} / [(P _{in} _{psia} - P _{out} _{psia})K] Where: K = P _{out} _{psia} if Δp ≤ 10% of P _{max} _{psia} K = (P _{in} _{psia} + P _{out} _{psia}) / 2 if Δp = 10 to < 25% K = P _{in} _{psia} if Δp > 25% and < 53% | Cv = Q/22.67 √ T / [(P _{in} - P _{out})K] |
| Eq. #27 | 64 | Average System Demand _{cfm} = (Compressor Delivery _{scfm} x Duty Cycle%) / (Compression Ratio x 100%) | ASD= (CD x DC) / (CR x 100) |
| Eq. #28 | 77 | Extension _{in} = (Cylinder Stroke _{in} x Input Signal _{volts}) / Total LRT Range _{volts} | E = (S x INP) / TR |
| Eq. #29 | 78 | Electromotive Force _{volts} = Current _{amps} x Resistance _{Ohms} | E = I x R |
| Eq. #30 | 78 | 1/R _t = 1/R ₁ + 1/R ₂ + 1/R ₃ +.....(Kirchoff's Law) | |
| Eq. #31 | 79 | Indicated Pressure _{psig} = (Full Range Pressure _{psig} x Output Signal _{mv}) / (Output Voltage _{mv/volt} x Excitation Voltage _{volts}) | IP = (FRP x OS) / (OV x EV) |
| Eq. #32 | 82 | Power _{watts} = E _{volts} x I _{amps} = I _{amps} ² x R _{Ohms} | |
| Eq. #33 | 83 | OP = [MP x (IS - PWCP)] / (PWFOP - PWCP) | |

Reference Equations

| FPS Pneumatic Specialist Certification | | | |
|---|---------------|---|---|
| Equations | Page # | Equation | Equation |
| Eq. #34 | 86 | $\text{Output Signal}_{mv} = [(\text{System Pressure}_{psig} / \text{Max TD Pressure}_{psig}) \times (\text{Max TD Signal}_{mv} - \text{Min TD Signal}_{mv})] + \text{Min TD Signal}_{mv} \text{ at } 0 \text{ PSIG}$ | $\text{OS} = [(SP / MP) \times (\text{Max S} - \text{Min S})] + \text{Min TD Sig.}$ |
| Eq. #35 | 87 | $\text{LVDT Resolution}_{mv} = \text{Full Scale Voltage}_{volts} / 2^{\text{bits}}$ | $\text{Rmv} = \text{FSV} / 2^{\text{bits}}$ |
| Eq. #36 | 87 | $\text{LVDT Resolution}_{in} = \text{Stroke}_{in} / 2^{\text{bits}}$ | $\text{Rin} = S / 2^{\text{bits}}$ |

Load and Motion Analysis

Load and Motion Analysis

Load and motion analysis requires a basic understanding of ratios, torque, speed, power, horsepower, friction, cylinder pressures and forces, shear strength, and some trigonometry.



Outcome 1.

Solves formulas for torque, speed and horsepower of an air motor connected through a reduction system to a conveyor.

Ratios are used to solve speed reduction problems. Air motors are available in sizes from 1/20th to 10 hp ratings at speeds from 300 to 10,000 rpm. For slow turning applications they often drive the load through a reduction system constructed with chains, belts or gears. When an air motor is “geared down”, the speed is decreased while the torque is increased.

The conveyor drive in Fig. 1 uses a pulley reduction system between the air motor drive shaft and the conveyor shaft. The speed ratio can be computed as the quotient of the pitch diameter or circumference of the output (driven) conveyor shaft to the pitch diameter or circumference of the input (drive) shaft. For example, if the air motor pulley had a pitch diameter of 3 inches and the conveyor shaft had a pitch diameter of 9 inches, the ratio would be:

$$\text{Speed Ratio} = \text{Output Shaft Speed}_{\text{rpm}} / \text{Input Shaft Speed}_{\text{rpm}} \quad \text{SR} = \text{OS} / \text{IS} \quad (\text{Eq. 1})$$

What this means is that the input shaft turns three times every time the output shaft turns once.

If a compound drive is used, that is a double or triple reduction through belts, chains, or gears, the final speed ratio is the product of the individual ratios.

Review: 1.1.

An air motor drives a shaft through a double reduction system using sprockets and chains. The air motor has a sprocket with 8 teeth driving an intermediate shaft with 40 teeth, the second sprocket on the intermediate shaft has 7 teeth connected to a final drive sprocket with 28 teeth. What is the final speed ratio between the air motor and final drive sprocket?

- 4 : 1
- 5 : 1
- 9 : 1
- 15 : 1
- 20 : 1

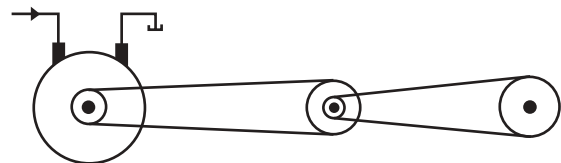

Fig. 1. The center pulleys are attached rigidly to each other.

Air motors impart a twisting or turning motion to the output shaft. This is called torque. Torque simply means to make an effort to twist or turn the shaft. It is measured as a force applied at a tangent to the circumference, at some distance from the center of the shaft. Torque can be measured with the shaft stationary or rotating. Both starting and running torque calculations are made for machines driven by air motors.

Numerically, the torque ratio is the same as speed ratio. In the example shown by Fig. 1, the air motor shaft

Load and Motion Analysis

turned three times for every turn of the conveyor shaft and the torque input to the conveyor shaft was three times the torque output of the air motor. Thus, gearing the air motor down increases the torque at the output, but at the expense of speed.

In the English system of units, torque is measured in pound-feet (lb-ft) or pound-inches (lb-in.). In the SI Metric system torque is measured in Newton-meters (N-m). The force unit, lb or N is applied at right angles to the radius of the shaft, while the length unit, inches, feet, or meters, is the distance from the center of the shaft to the place on the shaft where the force is applied at a tangent (right angle to the radius) to the circle.

The basic formula for torque is:

$$\text{Torque}_{\text{lb-in}} = \text{Force}_{\text{lbs}} \times \text{Radius}_{\text{in}} \qquad T = F \times R \qquad (\text{Eq. 2})$$

Notice that torque (lb. ft.) has the same units as work, (ft-lb.) except that the units are reversed by convention to reduce confusion. Also, remember that torque is a rotary or turning “effort”. This means the shaft can exert a torque, whether turning or not turning, as long as there is an effort to turn the shaft. For example, if an air motor driving a die grinder is turning 6000 rev/min it is exerting a torque. However, if the die grinder is stalled, it is still exerting a torque. Thus, the torque available from an air motor can be computed independently of speed.

Recall that torque is measured as a rotating or turning effort, while work is measured as a force F exerted through a distance D.

$$\text{Work}_{\text{ft-lbs}} = \text{Force}_{\text{lbs}} \times \text{Distance}_{\text{ft}} \qquad W = F \times D \qquad (\text{Eq. 3})$$

Review: 1.2.

A torque wrench registers 12 lb-ft. when a technician turns the input shaft on a conveyor like that shown in Fig. 1. When the technician checks the torque on an available air motor by applying shop air, the reading on the torque wrench is 6 lb-in. Neglecting friction, what gearing ratio would be necessary to provide the necessary torque to turn the conveyor?

- a. 2 : 1
- b. 8 : 1
- c. 16 : 1
- d. 24 : 1
- e. 32 : 1

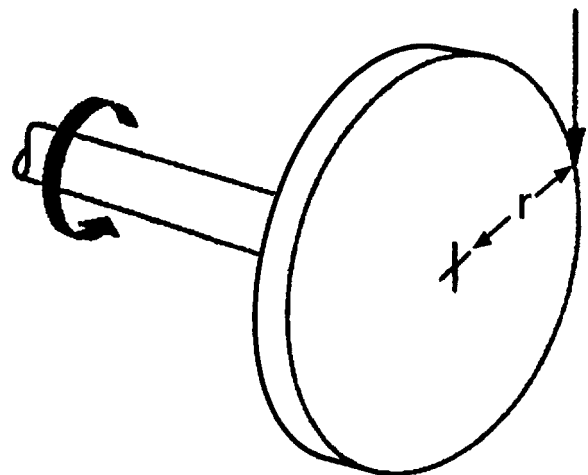

Fig. 2. Torque.

The rate at which work is performed is called power.

$$\text{Power} = (\text{Force}_{\text{lbs}} \times \text{Distance}_{\text{ft}}) / \text{Time}_{\text{seconds or minutes}} \qquad P = (F \times D) / t \qquad (\text{Eq. 4})$$

where the power is measured in ft-lb/sec or ft-lb/min. t = time in seconds or minutes.

Load and Motion Analysis

Air motors are typically rated by horsepower at a given pressure and rpm. Applications are made using performance graphs supplied by the manufacturer. Measurement of horsepower has historical significance in the work of James Watt, the famous inventor of steam engines. To solve the problem of rating his steam engines, Watt conducted experiments using horses to lift weights with a rope and pulley system. What he found was that a good horse could lift a weight at the rate of 550 pounds one foot in one second, and this has become the standard since that time. In Watt's honor, the electrical equivalent of a horsepower is 746 Watts.

The horsepower for rotating machinery can be computed from Watt's formula:

| | | |
|---------|--|----------------------|
| (Eq. 5) | Horsepower = (Speed _{rpm} x Torque _{lb-ft}) / 5252 | HP = (N x T) / 5252 |
| | Horsepower = (Speed _{rpm} x Torque _{lb-in}) / 63025 | HP = (N x T) / 63025 |
| | Horsepower = (Speed _{rpm} x Torque _{N-m}) / 7124 | HP = (N x T) / 7124 |
| | 1 hp = 746 watts = 746 N-m/sec = 550 lb-ft/sec | |

Review: 1.3.

What torque could be expected from an air motor that is rated at 2.5 hp at 2250 rpm?

- 0.93 lb-ft
- 1.07 lb-ft
- 1.97 lb-ft
- 5.84 lb-ft
- 8.54 lb-ft

Review: 1.4.

What torque could be expected from an air motor that is rated at 4 kw at 2400 rpm?

- 6.62 N-m
- 8.85 N-m
- 11.73N-m
- 11.87 N-m
- 15.92 N-m



Outcome 2.

Solves for the reaction force on a cylinder rod bearing from the stroke, mechanical advantage and side load on the rod.

Side loads on cylinder rods create a reaction force on the cylinder rod bearing. The cylinder rod becomes a second class lever with the piston acting as a fulcrum at one end, as the side force acts on the rod end at the other end. Here the load is positioned at the rod bushing somewhere in between. The side load on the rod end has a tendency to rotate the rod about the piston, with the magnitude of the load in one direction on the rod bushing being the same as the load on the piston in the other direction. Overloading the cylinder in this manner will wear the rod bushing on one side and the piston and cylinder bore on the other. If the lubrication film ruptures, galling can be expected.

Several applications in fluid power can be simplified and explained with levers and lever terminology. In addition, solving equations for levers is required to calculate the mechanical advantage of cylinders in various applications, reaction forces for cylinders subjected to side loading, and forces associated with grippers. Fig. 4 illustrates the three types of levers. Neglect the weight of the beam.

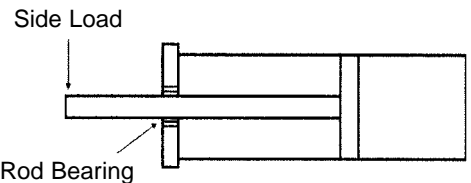

Fig. 3. Reaction force on a cylinder rod.

A “First Class” lever applies a force at one end of the lever which acts across a fulcrum to lift the load at the other. Notice that the lever pivots about the fulcrum somewhat like a teeter-totter. The relationship between force and distance is given by

$$F_1 \times L_1 = F_2 \times L_2 \quad (\text{Eq. 6})$$

where F_1 is the force applied, F_2 is the force at the load, L_1 is the distance between the applied force and fulcrum and L_2 is the distance between the force at the load and the fulcrum. The ratio of forces and lengths is derived from Eq. 6 as

$$F_1 / F_2 = L_2 / L_1 \quad (\text{Eq. 7})$$

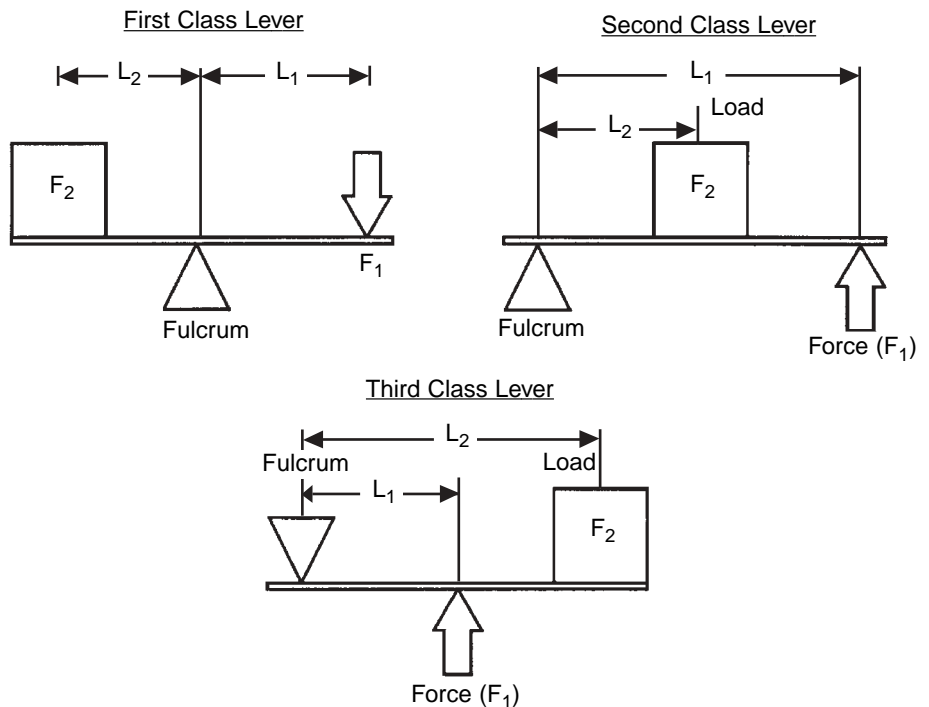

Fig. 4. “First Class”, “Second Class” and “Third Class” Levers.

In a “Second Class” lever the fulcrum is moved to one end. That is, the force is applied to one end and the lever pivots about the other with the load being placed somewhere in between. The equation that expresses the relationship between force and distance is the same as for a first class lever, except that the fulcrum and load are in a different position.

In a “Third Class” lever, the fulcrum is at one end of the lever and the load is at the other. The force to move the load is applied somewhere between the two ends of the lever. The equation that expresses the relationship

Load and Motion Analysis

between force and distance is the same as for first and second class levers, except the fulcrum and load are in a different position.

Here it must be remembered that the discussion of levers holds true only when the lever is at 90 degrees to the fulcrum. As soon as the lever begins to move, the change in angle will require trigonometric solutions of angles to solve for the direction and magnitude of forces.

Cylinders subjected to side loading act as levers. For example, the mechanical advantage of the rod subjected to a side load (force) acts against the bushing as a second class lever is given by:

$$\text{Mechanical Advantage} = \frac{\text{Total Rod Length}_{\text{in}}}{\text{Supported Rod Length}_{\text{in}}} \qquad \text{MA} = \text{TRL} / \text{SRL} \qquad (\text{Eq. 8})$$

Using the Second Class Lever Formula:

$$\text{MA} = L_1 / L_2$$

and the force equals the mechanical advantage multiplied by the magnitude of the side load acting on the rod.

$$\text{Reaction Force}_{\text{lbs}} = \text{Mechanical Advantage} \times \text{Side Load}_{\text{lbs}} \qquad \text{RF} = \text{MA} \times \text{SL} \qquad (\text{Eq. 9})$$

Review: 2.1.

If a cylinder similar to that in Fig. 3 has a 12 inch stroke and is extended 9 inches, what would be the reaction force on the rod bearing if the side load at the end of the rod were 40 lbs.?

- 40 lbs.
- 80 lbs.
- 120 lbs.
- 160 lbs.
- 200 lbs.

Load and Motion Analysis



Outcome 3:

Computes the bore diameter and pressure for a cylinder to move loads with a friction factor (Coefficient of Friction).

Friction increases the force required to move a given load along a surface. If a load resting on a horizontal surface is lifted there is no friction between the surface and the load, just the dead weight of the load. If the load is pushed horizontally, friction between the load and the surface increases the force required to move the load. How much the force is increased is determined by the friction factor. The force required to move a load along a horizontal surface is computed as the product of the friction factor and the load. That is,

$$\text{Horizontal Friction Force}_{\text{lbs}} = \text{Coefficient of Friction} \times \text{Load}_{\text{lbs}} \quad \text{HFF} = C_f \times L \quad (\text{Eq. 10})$$

If a load is resting on an incline, the total force required to move the load is determined from the sum of the force necessary to move the load along the surface plus the incline force which results from raising or lowering the load as it moves along the incline. Here, surface force and incline force are determined from the angle of the incline. Of course, loads being pushed up an incline require more force than loads being pushed down an incline.

The solution to problems where a load is being pushed along an incline requires solving a right triangle for the relative lengths of the sides. This can be done with the trigonometric functions, or for common angles, by inspection or the Pythagorean theorem ($a^2 + b^2 = c^2$). For example, the lengths of the sides of a right triangle where $\theta = 30^\circ$ are $a = \sqrt{3}$, $b = 1$, and $c = 2$. Similarly, the lengths of the sides of a right triangle where $\theta = 45^\circ$ are $a = 1$, $b = 1$, and $c = \sqrt{2}$.

Review: 3.1.

In fig. 5, a 1000 lb load is pushed horizontally. If the coefficient of friction between the surface and the load is 0.25, and the cylinder shown has a 3 inch bore diameter, what minimum air pressure given would be required to move the load?

- a. 36 psig
- b. 52 psig
- c. 64 psig
- d. 100 psig
- e. 200 psig

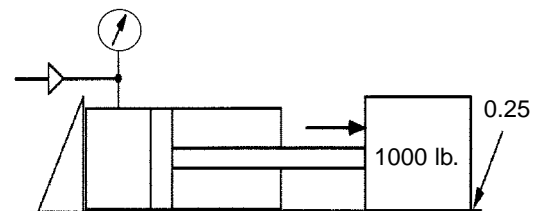
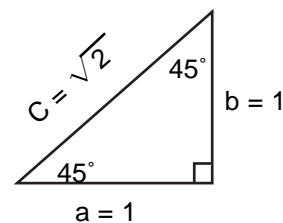
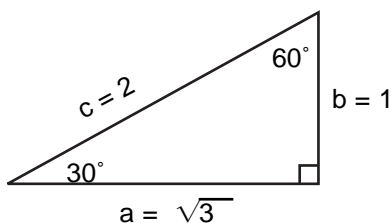
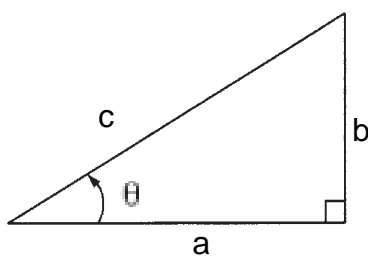

Fig. 5. Coefficient of friction calculation.



Load and Motion Analysis



$$\begin{aligned} \sin \theta &= \frac{\text{Opposite}}{\text{Hypotenuse}} = \frac{O}{H} = \frac{b}{c} \\ \cos \theta &= \frac{\text{Adjacent}}{\text{Hypotenuse}} = \frac{A}{H} = \frac{a}{c} \\ \tan \theta &= \frac{\text{Opposite}}{\text{Adjacent}} = \frac{O}{A} = \frac{b}{a} \end{aligned}$$

Fig. 6. Trigonometric solutions to right triangle

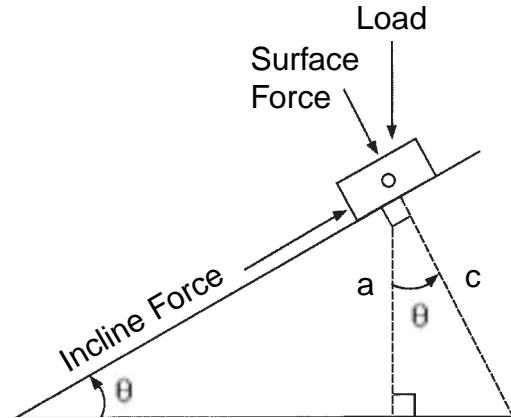

Fig. 7. Forces of a load on an incline

The force required to move a load up or down an incline consists of two components. The first component is the friction force required to move the load along the surface already defined as the surface friction force (SFF). The second component may be defined as the incline force (IF). The total force required to move a load up an incline is expressed by:

$$\text{Total Incline Force} = \text{Surface Friction Force} + \text{Incline Force}$$

The surface friction force is a function of the coefficient of friction of the surface, the cosine of the angle of the incline and the magnitude of the load. As the angle of the incline increases, the surface friction force decreases. This is because the drag between the load and the surface of the incline decreases as the angle of incline increases. Note that at an incline angle of 0° , the cosine equals 1.0. At an incline angle of 90° , the cosine equals 0.0, effectively eliminating the addition of the surface friction force component of the final force required to move the load along the incline. The surface force works at a right angle to the surface of the incline.

The incline force is a function of the coefficient of the surface friction, the sine of the angle of the incline and the magnitude of the load. The incline force rises as the angle increases. For example, the sine of 0° is zero, reflecting the fact that the load is not being lifted as it travels across the surface of the incline. If the incline has an angle of 30° , the sine is 0.50. If the angle of the incline is increased to 45° degrees, the value of the sine increases to 0.71, reflecting the fact that as the load moves along the incline, the load also rises vertically a greater amount as it moves along the incline. Taken to its natural conclusion, if the angle increases to 90° , the sine increases to a value of 1.0 and the movement along the incline turns into a pure lift of the load.

Therefore, as the angle of the incline increases, the surface force component of the equation decreases as the incline force component increases.

If the load is being moved up the incline, the incline force is positive. If the load is being moved down the incline, the incline force is negative. Integrating the formulas for the surface friction force and the incline force results in the following formulas:

$$\begin{aligned} \text{Total Incline Force}_{lbs} &= (\text{Coefficient of Friction} \times \text{Load}_{lbs} \times \cos \theta) \pm (\sin \theta \times \text{Load}_{lbs}) \quad (\text{Eq. 11.}) \\ \text{TIF} &= (\text{Cf} \times \text{L} \times \cos \theta) \pm (\sin \theta \times \text{L}) \end{aligned}$$

Note that you must add when the load is being moved up an incline, and subtract when the load is being moved down an incline.

Load and Motion Analysis

Review: 3.2.

A 750 lb. load is to be pushed up a 30° incline by an air cylinder with a 4 inch bore. If the coefficient of friction between the surface and the load is 0.35, what minimum gauge air pressure will be required to extend the cylinder to move the load?

- a. 24 psig
- b. 35 psig
- c. 48 psig
- d. 85 psig
- e. 109 psig

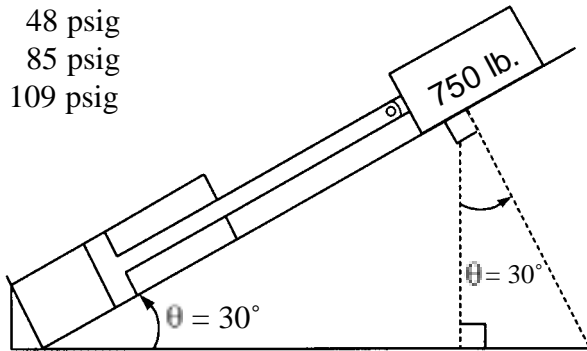

Fig. 8. Figure for Review 3.2.
Up Incline Forces

Review: 3.3.

A 2500 lb. load is to be moved down a 45° incline by an air cylinder extending. If the coefficient of friction between the surface and the load is 0.28, what load will be placed on the cylinder?

- a. - 495 lb.
- b. - 1068 lb.
- c. - 1278 lb.
- d. - 1821 lb.
- e. - 2263 lb.

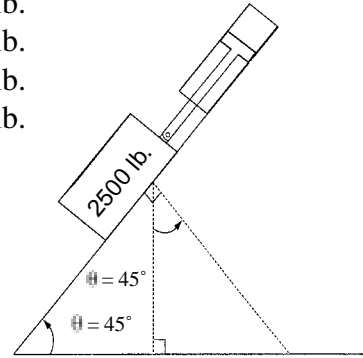

Fig. 9. Figure for Review 3.3.
Down Incline Forces

Load and Motion Analysis



Outcome 4:

Computes the cylinder bore diameter and pressure to operate a gripper through a mechanical advantage.

Air powered grippers have wide application in pick and place devices.

The gripper in Fig. 10 uses an air cylinder to pull two first class levers across a fulcrum. The force applied by the gripper is a function of the leverage such that (from Eq. 6)

$$F_1 \times L_1 = F_2 \times L_2 \quad (\text{Eq. 6})$$

where F_1 is the force on the lever at the cylinder end, L_1 is the distance from the air cylinder along the lever to the fulcrum, F_2 is the force applied by the gripper and L_2 is the length of the lever from the fulcrum to the gripper.

There is the misconception that the force from both jaws of a gripper is twice the force from each jaw. That is, if each jaw exerts 10 lb force, then the total force from two jaws must be 20 lb. Actually, the total force is only 10 lb because half the force provided by each jaw is used to counteract the other jaw. For purposes of discussion here, the force from a gripper will be that exerted by one jaw. In other words, think of one lever being fixed in place while the other lever is movable.

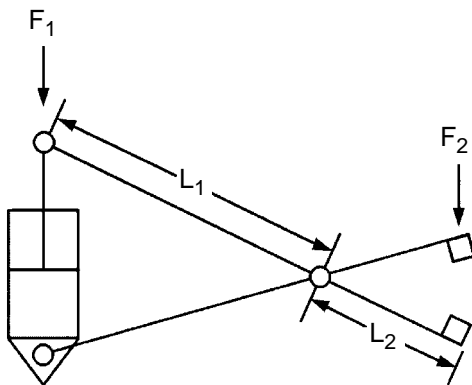

Fig. 10. Scissor gripper

Review: 4.1.

Estimate the gripper force in each finger if the air cylinder shown is supplied with 75 psig of air pressure.

- 30 lb.
- 88 lb.
- 118 lb.
- 177 lb.
- 236 lb.

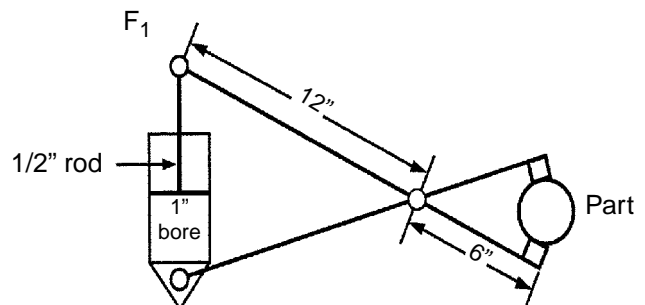

Fig. 11. Figure for Review 4.1.
Scissor Gripper Forces



Outcome 5:

Computes the shear strength of fixture attachments to retain rodless cylinder couplings under load.

Rodless pneumatic cylinders connect the piston to the load using a number of mechanisms.

One type of linear rodless cylinder employs a magnetic means of coupling the cylinder piston to the external load attachment plate. If the cylinder strokes the load horizontally, the magnetic connection must be strong enough to move the load against the effects of inertia. If the cylinder moves the load vertically, the magnetic coupling must be able to support the weight of the load as well as the force of acceleration. In both cases the magnetic coupling must withstand the shear force of the load resistance. Here it is assumed that the maximum shear force that the coupling can withstand is equal to the value of the load resistance supported in tension.

Review: 5.1.

The magnetically coupled rodless cylinder shown is to be used to move the load vertically. The load and load support fixture have a combined weight of 100 newtons. Assuming slow speed operation and ignoring start-up acceleration, calculate the minimum magnetic retaining force required to move the fixture in kilograms.

- a. 10.2 kg
- b. 22.5 kg
- c. 45.5 kg
- d. 90.9 kg
- e. 202.0 kg

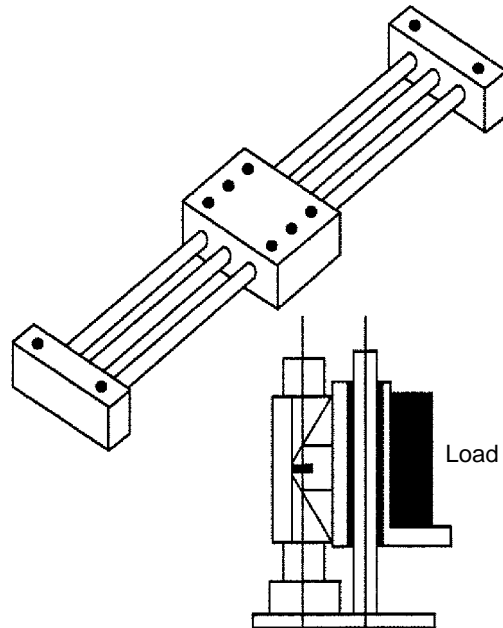

Fig. 12. Rodless cylinder with a magnetic coupling.

System Analysis and Troubleshooting

System Analysis and Troubleshooting



Outcome 6:

Computes the air cylinder pressure required to support jib-boom loads.

The jib-boom is an example of a third class lever. That is, one end of the lever rotates about a stationary pivot, the cylinder acts against the fulcrum of the lever somewhere between the two ends, and the free end of the lever is used to move the load.

Solving jib-boom crane problems like that illustrated in Fig. 13 for the force acting against the cylinder rod requires two steps. First, determine the vertical load at the fulcrum. Second, solve the right triangle for the force that acts against the cylinder on a line through the center of the rod.

For example, if the load at the end of the cylinder rod is given a value of 150 lb, the vertical load at the end of the cylinder rod can be determined from the balance of forces.

$$F_1 \times L_1 = F_2 \times L_2$$

Here we are solving for F_2 .

$$F_2 = \frac{F_1 \times L_1}{L_2} = \frac{150 \text{ lb} \times 6 \text{ ft}}{3 \text{ ft}} = 300 \text{ lb}$$

In figure 13 below, the force acting against the end of the cylinder rod can be determined by solving the right triangle using trigonometric functions, but by inspection it can be seen that for a right triangle where the other two angles are 45° , the relative side lengths are 1, 1, and $\sqrt{2}$ which equals 1.414. Therefore, the force on the cylinder rod is $1.414 \times 300 \text{ lb} = 424.2 \text{ lb}$.

Review: 6.1.

If in Fig. 13, the angle between the cylinder rod and boom was 45° , what minimum theoretical pressure would there be in a cylinder with a 3 inch bore?

- a. 35 psig
- b. 50 psig
- c. 85 psig
- d. 170 psig
- e. 185 psig

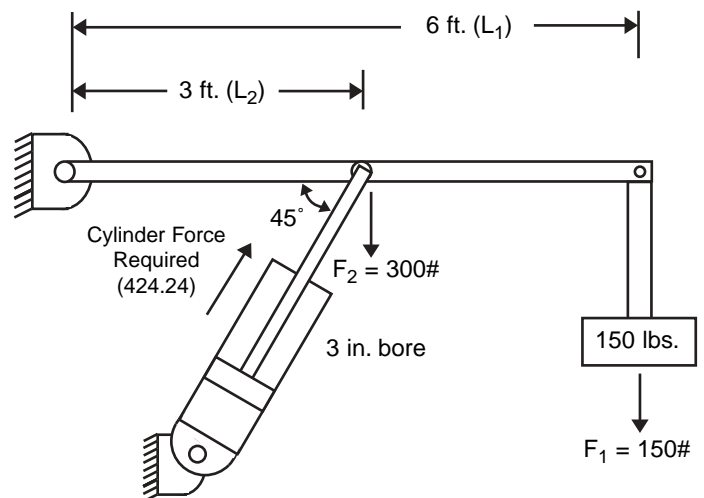

Fig. 13. Jib boom



Outcome 7: Solves for the pressure and suction area to provide a required lifting force using vacuum cups.

Vacuum cups are used for handling smooth surfaced material. This technique for lifting and moving loads has particular advantages in handling sheet glass and other products that have a smooth surface and few places for attachment of mechanical hooks and grippers.

The cup is attached by placing it against the surface and then drawing a vacuum, with the force required to pull the cup away from the surface proportional to the vacuum and size of the cup. The higher the vacuum, or larger the suction cup, the stronger the pull force required to detach the vacuum cup.

One way to determine the lifting force of a vacuum cup is to make the conversion between inches of mercury (in-Hg.) and psig, and then solve for the available negative pressure in absolute terms to power the vacuum cup. Standard conditions = 29.92 in-Hg., 68° F and 36% humidity,

$$1 \text{ in-Hg} = 0.4912 \text{ psig}$$

$$1 \text{ psig} = 2.036 \text{ in-Hg}$$

Therefore, each inch of mercury drop in pressure = 0.4912 psig negative gauge pressure. For example, if a vacuum system has an absolute pressure of 24 in-Hg., the negative gauge pressure to operate a vacuum cup would be:

$$\text{Pressure}_{\text{psig}} = \text{Pressure Drop}_{\text{in-Hg}} \times -0.4912 \text{ psig/in-Hg} \qquad \text{PSIG} = \text{PD} \times -0.4912 \qquad (\text{Eq. 13})$$

and:

$$-p = (29.92 \text{ in-Hg} - 24 \text{ in-Hg}) \times (-0.4912 \text{ psi/in-Hg}) = -2.9 \text{ psig}$$

A vacuum of less than 1 in-Hg is measured in microns, where

$$1 \text{ micron} = 0.000 \ 001 \text{ meter} = 0.001 \text{ mm}$$

Review: 7.1.

How much pressure drop in in-Hg would be required to lift a car hood weighing 120 lb. using two 4 inch diameter vacuum cups? Allow a safety factor of 2.

- 9.55 in-Hg pressure drop.
- 14.68 in-Hg pressure drop.
- 15.63 in-Hg pressure drop.
- 19.44 in-Hg pressure drop.
- 28.00 in-Hg pressure drop.

Review: 7.2.

What is the psig equivalent of 1 micron of mercury pressure drop?

- 0.000 000 812 psid
- 0.000 001 466 psid
- 0.000 003 959 psid
- 0.000 019 343 psid
- 0.000 038 722 psid



Outcome 8:

Converts pressure readings between inches of water and inches of mercury (in-Hg).

Air has mass and exerts pressure on the surface of the earth. A barometer consisting of an inverted tube closed at the top will support a column of mercury (Hg.) at exactly 760 mm (29.92 in.) at sea level when measuring standard conditions at 68° F. Since mercury has a specific gravity (SG) of 13.6, this is the equivalent of:

$$29.92 \text{ in-Hg} \times (1 \text{ ft} / 12 \text{ in-ft}) \times 13.6 = 33.9 \text{ ft-H}_2\text{O}$$

$$1 \text{ in-Hg} = 1.133 \text{ ft-H}_2\text{O} \qquad 1 \text{ ft - H}_2\text{O} = 0.8826 \text{ in-Hg}$$

While the standard for atmospheric pressure is 760 mm (29.92 in.) of mercury, pressure measurements are also made using manometers that measure head in inches of H₂O and other liquids. The conversion between in-Hg and in-H₂O is:

$$\text{Pressure}_{\text{ft-water}} = \text{Pressure}_{\text{in-Hg}} \times 1.133 \qquad \text{ft-H}_2\text{O} = \text{in-Hg} \times 1.133 \qquad (\text{Eq. 14})$$

Review: 8.1.

If a barometer will support a 760 mm column of mercury at standard atmospheric conditions, how many feet of water would this be? (Round the answer to one place)

- a. 6.0 ft
- b. 10.2 ft
- c. 24.0 ft
- d. 27.6 ft
- e. 33.9 ft



Outcome 9:

Uses manufacturer's graphs and formulas to determine cfm requirements for an air motor.

Air motors are generally sized by their horsepower at rated input, usually 90 psig. Then this air consumption is used to size the valving and the compressor. The horsepower and speed of a given motor can be changed by throttling the inlet, so the common practice is to size the motor to provide the torque needed at 2/3 of line pressure. Full line pressure can then be used for start-up and overloads.

Each manufacturer supplies curves with the power output range given for several pressures. If, for example a 1 hp motor was required with a speed of 2000 rpm, the motor would be selected that provided this power at 2/3 of the line pressure available. Fig. 14 shows two common graphs used to rate air motors.

cfm = Flow rate in cubic feet per minute, at a given pressure.

scfm = Flow rate in standard cubic feet per minute at standard conditions (14.7 psia, 68°F 36% relative humidity).

The graphs in Fig. 14 are helpful to make calculations for motor torque and air consumption. If the rotation speed of the motor is given, it may be necessary to solve the horsepower formula (Eq. 5) for torque to arrive at the air pressure using the torque vs. motor speed graph. Then air pressure and motor speed can be used to solve for air consumption using the scfm vs. motor speed graph.

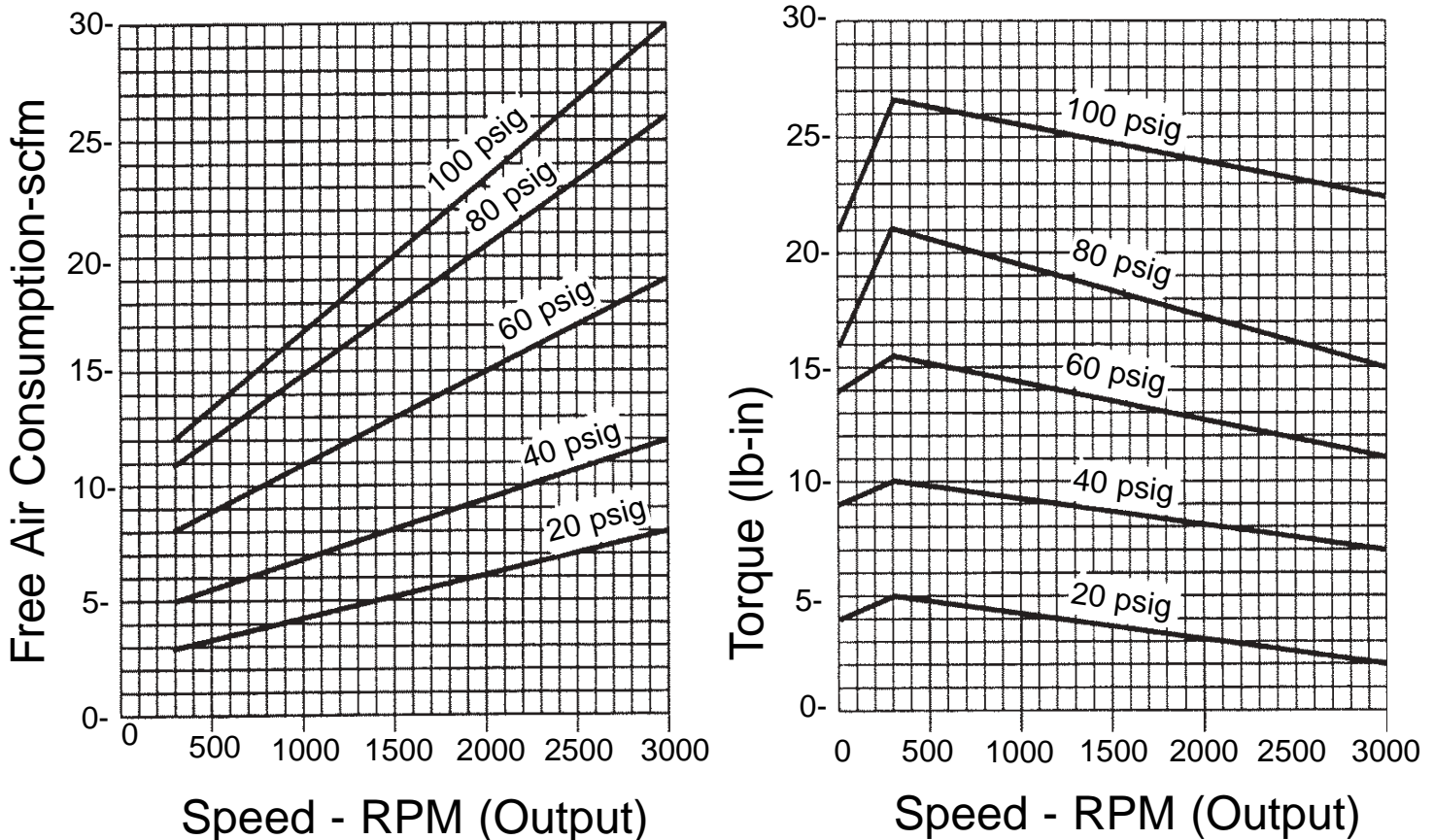

Fig. 14. Air motor graphs.

Review: 9.1.

A 1/4 hp air motor is selected to operate at 1200 rpm. Using various calculations and the graphs in Fig. 14, what minimum air pressure listed would be required?

- a. 30 psig
- b. 40 psig
- c. 50 psig
- d. 60 psig
- e. 70 psig

Review: 9.2.

If an air motor operates under load at 2000 rpm and develops 17 lb-in. of torque, approximately how much air in scfm will it consume? Use Fig. 14 to derive an answer.

- a. 10 scfm
- b. 15 scfm
- c. 20 scfm
- d. 25 scfm
- e. 30 scfm



Outcome 10: Predicts the operation of a pneumatic circuit from the placement of components in the circuit.

The simplest pneumatic circuit consists of a single-acting cylinder powered by a manually operated three-way directional control valve. The directional control valve, which in this case is palm operated and spring returned, is sometimes called the power valve because it handles the main air flow to power the actuator. In the normal (Off) position the power valve vents the line to the cylinder, allowing the spring to retract the cylinder. Depressing the palm operator shifts the valve to the upper envelope sending air to the blind end of the cylinder. Pressure builds in a few milliseconds and air flow extends the cylinder against the force of the return spring. The action is “press the palm button” to extend, “release the palm button” to retract. For the cylinder to remain extended, the palm button would have to be held depressed.

The operation of air circuits is easier to understand if components are identified with a specific purpose. Four types of components are identified here with open-loop control systems. “Open-loop” simply means that the circuit is controlled by a sequence of operations. In contrast, a “closed-loop” circuit incorporates a feedback loop in the control system that measures the pressure, force or position at the actuator and sends an error signal back to correct the input. Most pneumatic systems have an open-loop control system.

The number and description of component functions varies, depending upon the reference cited and the level of sophistication of the circuit. What they are called is less important than understanding the purpose that each component serves.

1. Working components.
2. Signal output components.
3. Signal processing components.
4. Signal input components.

Beginning at the output of the circuit, air cylinders and motors are called working components. They convert the energy of pressurized air to mechanical energy that moves the load. Working components are located downstream of the directional control valve.

Directional control valves, commonly called power valves, are signal output components. They direct pressurized air from the air source to cylinders and motors. They are called power valves because they direct the main air stream that powers the actuator.

Limit valves, shuttle valves, quick exhaust valves, check valves and flow control valves are called signal processing components. They control the circuit while it is operating.

Finally, the FRL unit (filter-regulator-lubricator), (power) lockout valves, start valves and stop valves are called signal input components. Signal input components are located upstream of the power valve.

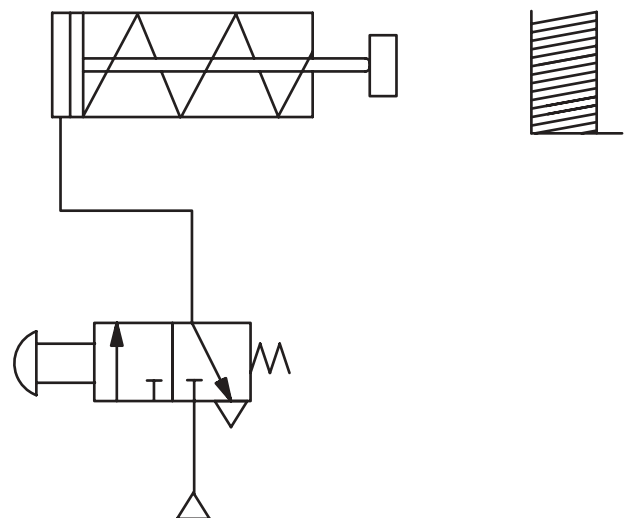

Fig. 15. Single-acting cylinder circuit.

System Analysis and Troubleshooting

Air circuits are constructed to fulfill specific functions. Circuit functions are identified by name. For example, meter-in circuits control the flow of air to the cylinder with a one-way throttling restriction (flow control valves). A one-way check valve is plumbed around the restriction to allow free-flow in the reverse direction (flow control valves). Meter-out circuits control the flow of air from the cylinder through a one-way throttling restriction to prevent the cylinder from lunging. Meter-out circuits also incorporate a one-way check valve plumbed around the restriction to provide unrestricted flow to power the cylinder in the opposite direction. Reciprocating cylinder circuits extend and retract automatically after the start valve is actuated. Time delay cylinder circuits extend and retract after a preset time. Quick exhaust circuits direct the return port of the cylinder to atmosphere to relieve back pressure. This speeds up the cylinder on the return stroke because air is released at the cylinder rather than routed back through the directional control valve. Two pressure circuits extend a cylinder under load at high pressure with maximum force, and retract the cylinder with no load at low pressure and minimum force. This saves air and reduces high impact loads on the cylinder, which would otherwise occur when the cylinder retracts. Sequence circuits order the sequence of operation of two or more cylinders using operator control, stroke limit valves, travel time, pressure sequence or programmed control. Slow forward, fast return circuits typically extend the cylinder slowly during the work portion of the cycle, and retract the cylinder at high speed during the slack portion of the cycle. Switching circuits are logic circuits that incorporate interlocks to operate the work actuator, while preventing unintended movement of actuators that are not performing a work function. Safety circuits are also logic circuits that prevent personnel from being injured. The most common examples of safety circuits are two-hand, anti tie-down, start circuits for presses and rotating machinery.

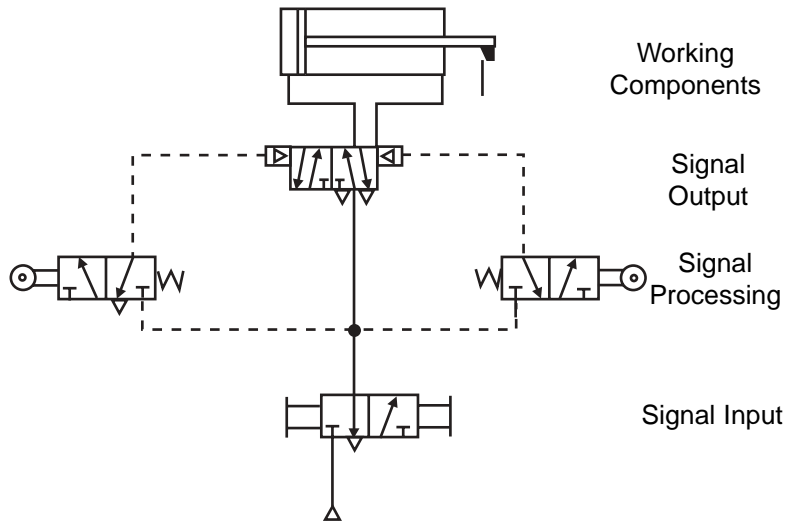

Fig. 16. Working, signal output, signal processing and signal input components.

The circuit shown in Fig. 17 is a time delay circuit because there is a small timing volume (accumulator) in the pilot line that stores air much like an electrical capacitor stores an electrical charge. The circuit consists of a working component (cylinder), signal output component (two-position power valve), signal processing components time delay valve (consisting of an adjustable orifice and a free flow return check) and a signal input component (start valve A).

Operation depends upon where each component is located in the circuit and how it is plumbed. For example, as shown, the pilot signal from start Valve A will shift the power valve to extend the cylinder. The pilot signal also will meter through the orifice of the flow control valve and, after a time, charge the accumulator at right, putting equal pressure from the same air source on both pilots of the directional control power valve. The pilot signal on the right side of the power valve, together with the bias spring, will shift the power valve left to the position shown and retract the cylinder. Thus, depressing and holding the palm button on power valve A will cause the cylinder to extend, followed after a time by retracting, where it will remain until Valve A is released and depressed to recycle the cylinder.

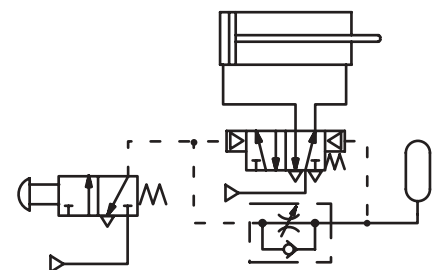

Fig. 17. Time delay (one-shot) circuit.

Review: 10.1.

After reversing the check valve, which one of the following would likely occur if the palm operated valve in the circuit shown in Fig. 17 were operated and held depressed?

- a. The cylinder would lock up and after a time extend.
- b. After a time delay, the cylinder would extend.
- c. The cylinder would extend and stay extended.
- d. The cylinder would fully extend and after a time retract.
- e. The cylinder would partially extend and then retract.



Outcome 11:

Predicts the operation of a pneumatic system by tracing the path of air flowing through various circuits when various commands are given.

Fig. 18 shows a sequence circuit with three output cylinder actuators labeled 10, 11, and 12. These are the working components of the circuit. There are three power valves in the circuit labeled 6, 7, and 8. These are the signal output components. There are four limit valves, labeled 2, 3, 4, and 5. These are signal processing components, together with the three shuttle valves that are not labeled.

Signal input components include the FRL unit, the main air key lock valve and the start valve, labeled 1 in the circuit. Operation of the circuit is predicted by tracing the flow of air from the signal input components to the signal processing components, then to the signal output component, and finally to the working components.

The circuit in Fig. 18 operates as follows: With key lock valve 9 in the actuated position, air is directed to three places:

1. Power valves 6, 7, and 8.
2. Signal processing limit valves 2, 3, 4 and 5.
3. Signal input start valve 1.

Since all three signal output power valves are receiving air, the cylinder actuators will operate. That is, the cylinders will either be extending, retracting, or remain extended or retracted.

The air signal through limit valve 5 is directed to the right pilot of power valve 8 through the shuttle valve, causing cylinder 12 to retract, no matter what previous position it was in.

When signal input start valve 1 is depressed and released, pilot air is directed to the left pilot of power valve 6, causing it to shift to the left envelope which extends cylinder 10. Notice that the right pilot of power valve 6 is vented back through key lock valve 9, and that return air from the rod side of cylinder 10 is exhausted to atmosphere through power valve 6.

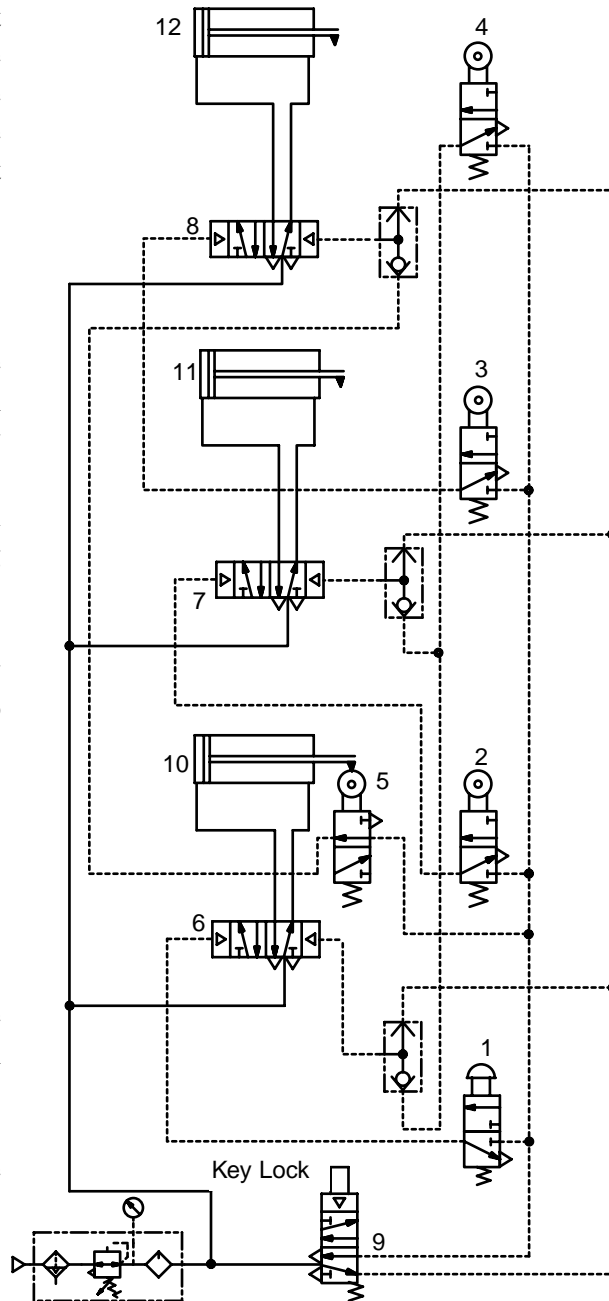

Fig. 18. Air circuit with three cylinders.

System Analysis and Troubleshooting

When cylinder 10 reaches its extended limit it actuates limit valve 2, directing pilot air to the left side of power valve 7, shifting the valve to extend cylinder 11.

When cylinder 11 reaches its extended limit it actuates limit valve 3, directing pilot air to the left side of power valve 8, shifting the valve to extend cylinder 12.

When cylinder 12 reaches its extended limit it actuates limit valve 4, directing pilot air to the right side of power valve 7 and power valve 6. Power valve 6 shifts first to retract cylinder 10 because the left pilot is vented back through open start valve 1.

When cylinder 10 retracts, releasing limit valve 2, the left pilot of power valve 7 is vented so that pilot air from limit valve 4 can shift power valve 7 to the left, retracting cylinder 11.

When cylinder 10 reaches the retracted position it operates pilot valve 5, which sends a pilot signal to the right side of power valve 8, retracting cylinder 12. Here the system comes to rest until start valve 1 is depressed again.

Review: 11.1.

With key lock valve 9 and start valve 1 in the normal (off) position, what will be the final position of cylinders 10, 11 and 12?

- a. cylinder 10 retracted, cylinder 11 retracted, cylinder 12 retracted.
- b. cylinder 10 retracted, cylinder 11 retracted, cylinder 12 extended.
- c. cylinder 10 retracted, cylinder 11 extended, cylinder 12 extended.
- d. cylinder 10 extended, cylinder 11 extended, cylinder 12 extended.
- e. cylinder 10 extended, cylinder 11 extended, cylinder 12 retracted.

Review: 11.2.

With key lock valve 9 in the actuated position, if start valve 1 is depressed and held depressed, what would be the final position of cylinders 10, 11, and 12?

- a. cylinder 10 extended, cylinder 11 extended, cylinder 12 extended.
- b. cylinder 10 retracted, cylinder 11 retracted, cylinder 12 retracted.
- c. cylinder 10 extended, cylinder 11 retracted, cylinder 12 extended.
- d. cylinder 10 retracted, cylinder 11 extended, cylinder 12 retracted.
- e. cylinder 10 extended, cylinder 11 extended, cylinder 12 retracted.



Outcome 12: Predicts the operation of a pneumatic system by tracing a malfunction to a faulty component.

There are a number of problems that can cause a component to fail. For example, in Fig. 18, key lock valve 9, start valve 1, and limit valves 2, 3, 4, and 5 have return springs. If the springs were to break, the valves would fail to return to the normal position. A similar problem can occur with limit valves 2, 3, 4, and 5 should the valve spool stick because of contamination or rusting. The shuttle valves in the right pilot lines of power valves 6, 7, and 8 can stick, particularly if the system has a lot of moisture and is not used frequently.

To identify how a component malfunctions, one must know what each component is supposed to do in the circuit, and how the component operates. For example, in the circuit in Fig. 18, limit valves 2, 3, 4, and 5 are used to sequence the circuit. That is, when cylinder 10 extends, it depresses limit valve 2 to pilot operate power valve 7 to extend cylinder 11. This means that cylinder 11 extends in sequence after cylinder 10.

The three shuttle valves in the circuit provide alternate inputs to pilot power valves 6, 7, and 8 to retract cylinders 10, 11, and 12. When key lock valve 9 is in the normal (off) position, pilot air is supplied through the top of all three shuttle valves. When key lock valve 9 is in the run position, the shuttle valves for power valve 6 and 7 receive pilot air from limit valve 4 through the bottom, and the shuttle valve for power valve 8 receives pilot air from limit valve 5 through the bottom. Thus, pilot air to shift power valves 6, 7, and 8 to retract cylinders 10, 11, and 12 can originate from two sources.

Review: 12.1.

How would the circuit in Fig. 18 operate if limit valve 2 were to stick passing with key lock valve 9 in the run position, after start valve 1 was depressed and released?

- a. cylinder 10 would not retract.
- b. cylinder 11 would not retract.
- c. cylinder 12 would not retract.
- d. cylinder 11 and 12 would retract.
- e. cylinder 11 and 12 would not retract.



Outcome 13: Identifies the most likely fault in a pneumatic circuit from symptoms and operational characteristics.

Faults in a pneumatic system are typically traced backward through the system from working components (cylinders and motors) to signal components (power valves), then to signal processing components (limit valves) and finally signal input components (start valve). Normal procedure is to operate power valves, limit valves, and start valves manually until the fault is located.

A word of caution is in order here. Inexperienced personnel should not be involved with troubleshooting a pneumatic machine. Putting a machine in motion by switching components can be dangerous to maintenance personnel and anyone else working on the machine. Remember that air is silent and when components such as valves are switched, actuators will move without warning. This poses an unsafe condition to inexperienced maintenance personnel. Do not actuate components such as power valves and limit valves randomly. Before switching any component be sure the function of that particular component has been identified and is understood. The anticipated movement of the machine members should be known, and safety precautions taken, so that personnel are not put at risk by moving actuators.

Review: 13.1.

All three cylinders in Fig. 18 are retracted. After key lock valve 9 has been set to the run position, start valve 1 is depressed and released but nothing happens. The air pressure gauge shows 100 psig. What component is most likely stuck?

- a. Limit valve 2.
- b. Power valve 8.
- c. Limit valve 5.
- d. Power valve 6.
- e. Shuttle valve at power valve 6.



Outcome 14: Predicts the operation of a pneumatic system when special commands are given (System Shutdown, Emergency Stop, Interrupted Air, Error Signal).

There are four common conditions that require analysis by the pneumatic specialist:

1. Predicting the operation by tracing the path of air flowing through the circuit when various commands are given.
2. Troubleshooting the operation by tracing a malfunction to a faulty component.
3. Identifying the most likely fault from symptoms and operational characteristics.
4. Predicting operation when special commands or signals are given. For example, system shutdown, emergency stop, interrupted air or an error signal.

The circuit, shown in Fig. 18 (page 29), supplies air through the FRL to power valves 6, 7, and 8, and to key lock valve 9. The normal position for the key lock valve is shown. That is, the return spring holds the valve internal mechanism such that air is passing through passages in the lower envelope. When the valve is actuated, the internal mechanism is moved such that air is passing through passages in the upper envelope. No information is given that would suggest the position in which the valve is locked, though the normal position is the more likely.

One special condition occurs if key lock valve 9 is returned to the normal position to shut down the system while the circuit is in the position shown. If this occurs, cylinders 10, 11, and 12 will remain in the retracted position with air directed through power valves 6, 7, and 8 to hold them there.

If the circuit is operating, and the cylinders are in an intermediate position, pilot air is directed to the right sides of power valves 6, 7, and 8. At the same time, air is directed through power valves 6, 7, and 8 to retract cylinders 10, 11, and 12, where they will remain with pressure applied to the rod side of the pistons.

If start valve 1 is depressed with the key lock valve in the normal position, nothing will happen since there is not a source of air to the valve. However, another special condition occurs if the key lock valve is in the actuated position and the operator holds start valve 1 in the depressed condition.

During normal operation, when start valve 1 is depressed and released cylinders 10, 11, and 12 extend, and then retract. Thus, start valve 1 initiates a one cycle sequence. The retraction portion of the cycle is allowed to begin because start valve 1 vents the left side of power valve 6. After one cycle, the system remains inactive with all three cylinders held under pressure in the retracted position.

If the operator ties down start valve 1 in the mistaken belief that the cycle will repeat, the left side pilot of power valve 6 will not be vented. cylinders 10, 11, and 12 will extend normally, but when limit valve 4 is actuated, pilot air cannot actuate power valve 6 to retract cylinder 10. The same is true for cylinder 11. Since cylinder 10 is in the extended position, limit valve 2 is actuated, directing pilot air to the left side of power valve 7, preventing pilot air from actuated limit valve 4 that is now directed to the right side from shifting it. Since power valve 8 receives pilot air from limit valve 5 to retract cylinder 12, all three cylinders will remain in the extended position under pressure.

Review 14.1.

In Fig. 18 (page 29), if the incoming air supply line that leads to power valves 6, 7, and 8 was disconnected and then reconnected to the upper right line of key lock valve 9, how would the operation of the circuit be affected?

- a. Power air would then pass through start valve 1.
- b. Key lock valve 9 would act as an air relief valve.
- c. With key lock valve 9 in the normal position, supply air is not vented.
- d. After the key lock valve is actuated, depressing start valve 1 would operate the circuit normally.
- e. All cylinders would remain in the retracted position.

System Design

Outcome 15:

Selects the appropriate solution to control air cylinder velocity.

Because air is a spongy fluid, controlling the speed of actuators is a special problem. A pressurized air cylinder that is not under load will extend and/or return suddenly if the exhaust air is not controlled. This is often the case and is not likely to cause damage since most air cylinders are engineered with shock pads, or incorporate external stops on the cylinder rod to prevent the piston from bottoming internally against the head and cap ends. Unlike hydraulics, most applications require full extension or full retraction without an intermediate position.

If velocity control of an air cylinder is required, the rule of thumb applied is, “when in doubt, meter out.” This is not to say that air cannot be metered into a cylinder to control velocity, but unless a constant restrictive load it being moved, the cylinder will lurch as air pressure builds to the requirement of the load and then expands suddenly in the cylinder dropping the pressure, only to repeat the process and lurch again.

The rpm of air motors, on the other hand, is commonly controlled by the pressure at the inlet. Many air motors power constant loads, so it is more cost effective to regulate the pressure than to provide a restriction at the inlet or outlet that wastes power needlessly.

Figure 19. illustrates a double-acting cylinder mounted vertically with a load hanging on the cylinder rod. If the flow controls (A & B) were to be reversed for "meter-in" control, the load would drop suddenly when the solenoid valve is signalled to lower the load. "Meter-in" flow control would cause uncontrollable lowering and a hazardous condition.

Notice there are flow control valves in each cylinder line of the circuit to control the velocity. Each flow control valve allows air to pass freely in one direction and to be restricted in the other. As the valves are configured in the circuit, shifting the power valve to raise the load allows free flow of air through the check valve to the rod end of the cylinder to lift the load, but restricts flow from the cap end back through the control valve to prevent the cylinder from retracting suddenly should the load be removed. Shifting the directional control valve to extend the cylinder and lower the load directs air to the cap end of the cylinder through the check valve. Return air from the rod end of the cylinder must pass through the restriction, preventing the load from dropping suddenly. This is a meter-out circuit.

Review: 15.1.

Referring to Fig. 19, which valve configuration would require the lowest pressure while the load is being lifted?

- Remove the flow control at valve B.
- Reverse flow control check at valve A.
- Reverse flow control check at valve B.
- Reverse flow control checks at valves A and B.
- Leave flow control valves A and B as they are.

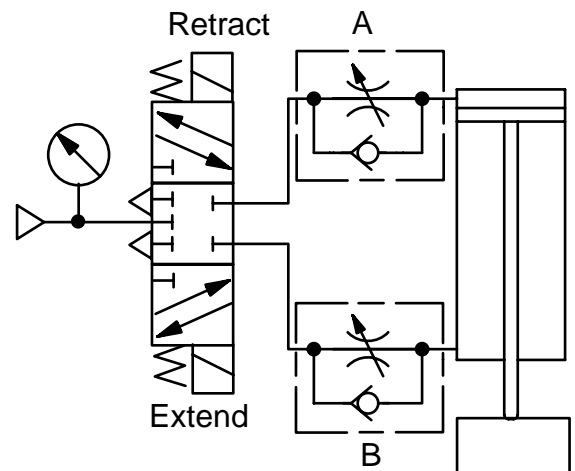

Fig. 19. Velocity control for an air cylinder.



Outcome 16: Selects the location of various components in a circuit to achieve cylinder sequence functions.

Sizing a cylinder or motor actuator to achieve an objective is a straightforward task. For example, a typical working component might be required to move a loaded carton sideways off a conveyor line onto a packing station. Here the force and distance requirements are known and air pressure available is used to size the cylinder.

Working backwards from the cylinder actuator, the power valve is sized to meet the air requirements of the cylinder at the required operating pressure. Thus, both the working component and signal output component have been specified. The air lines must also be sized to provide the required air flow rate within acceptable limits of pressure drop.

What is more difficult to engineer into the circuit are signal processing components (limit and interlock valves, for example) and signal input components (start, stop, shutdown and emergency valves) to achieve the desired sequence of operations under specified conditions. For example, having a cylinder that extends and retracts automatically requires one set of controls. Having that same cylinder extend and dwell for a time before retracting, or remain retracted for a time before extending, requires another set of controls.

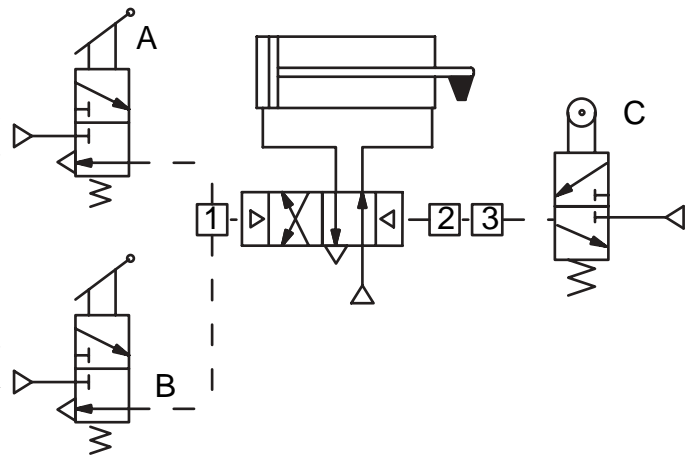

Fig. 20. Signal processing components to control a cylinder circuit.

Figure 20 illustrates a cylinder circuit that extends and retracts. The signal input is from either one of two hand actuated valves, A or B, to shift the power valve and cause the cylinder rod to extend, and at the end of the stroke the rod contacts the signal processing limit valve C to cause the cylinder rod to retract.

If signal processing components are selected to achieve desired results, the first task is to identify those desired results and then select components that will achieve them.

Consider the circuit in Figure 20. The cylinder should extend, then dwell before retracting. If the operator momentarily operates either valve A or B, the cylinder will extend. After the cylinder fully extends and trips limit valve C, it will begin to retract after an adjustable dwell time. Several components must be installed in blocks one through three in order to achieve this result.

To allow two station control, a shuttle valve must be installed in position 1. A shuttle valve will accept the higher of two pressures and produce an output signal. If both input signals are at the same pressure, the first input signal will take precedence and block the other signal.

The time delay for retraction requires an adjustable orifice and perhaps a timing volume in which to store pilot air that will allow pressure to build up to shift the power valve. Thus, block 2 would be a volume chamber to dampen the orifice time delay control and block 3 would be an adjustable orifice. When the cylinder fully extends, it contacts a limit valve to pilot operate the power valve to retract the cylinder rod.

Review: 16.1.

The circuit shown in Fig. 21 should extend one cylinder followed by extending the other. Both cylinders should retract. Which component should be installed in position A to achieve proper operation?

- a. Component 1
- b. Component 2
- c. Component 3
- d. Component 4
- e. Component 5

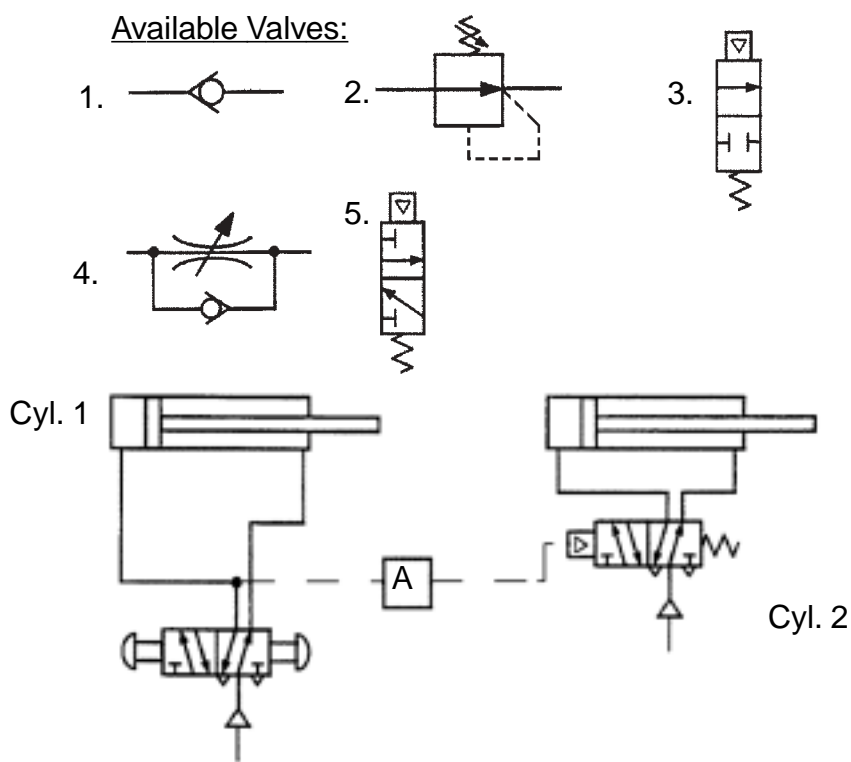

Fig. 21. Two cylinder sequencing circuit.



Outcome 17: Selects the location of various components in a circuit to achieve a deceleration function.

Linear pneumatic circuits require a means to stiffen the travel of the cylinder rod if velocity control or a deceleration function is required. Typically, this is done by coupling a pneumatic cylinder to a hydraulic cylinder and then regulating the flow of hydraulic fluid from one side of a double rod cylinder to the other.

If the objective is simply to stiffen and regulate cylinder rod velocity, an adjustable needle valve valve can be placed between the ports of a double rod hydraulic cylinder. As the pneumatic cylinder extends, oil in the hydraulic cylinder flows from one port of the cylinder to the other, and when the cylinder rod retracts, the flow is reversed, so that velocity control is the same in both directions.

If velocity control in one direction is the objective, a check valve can be installed in parallel with the needle valve. The stroke will then be damped in one direction by flowing oil through the regulating orifice from one cylinder port to the other, and back through the reverse free flow check valve to provide nearly unrestricted flow in the opposite direction.

Deceleration of the same circuit is possible if the check valve is replaced by a pilot operated two way valve that opens or closes the circuit, depending upon whether the circuit is to be decelerated with the cylinder rod extending or retracting.

Fig. 22 shows a circuit that can be used to stiffen or decelerate a pneumatic cylinder. The cylinder on the left is the pneumatic actuator. The cylinder on the right is a double-acting, double rod hydraulic cylinder that provides equal areas on both sides of the piston. Components A and B are signal processing components for the hydraulic portion of the circuit. Component A is placed in the flow regulating part of the circuit, while component B provides pilot signals in response to the position of the cylinder rod. Component A would be a valve, while component B would be a valve operator.

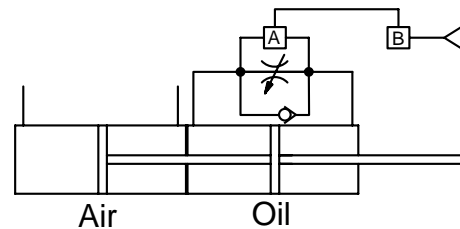

Fig. 22. Pneumatic Velocity control circuit.

Review: 17.1.

In Fig. 22, what components should be placed in boxes A and B to decelerate the cylinder near the end of the extension stroke?

- a. Valve 2 in box A, valve 1 in box B.
- b. Valve 1 in box A, valve 2 in box B.
- c. Valve 2 in box A, valve 5 in box B.
- d. Valve 1 in box A, valve 6 in box B.
- e. Valve 2 in box A, valve 2 in box B.

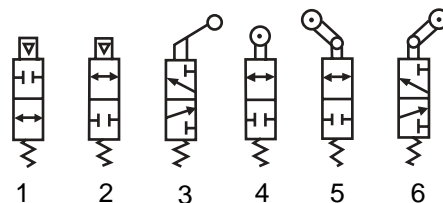

Fig. 23. Signal processing components for Review 17.1.

System Design



Outcome 18:

Selects conductor sizes from application charts given pressure, flow delivery and line length.

Air piping systems are generally constructed of Schedule 40 pipe and tubing, and should be sized to minimize pressure losses between the compressor and piping drops, where the air is used to power tools and equipment. As a general rule, the piping system should be large enough to maintain a working pressure of 90% of the supply pressure when air tools and machinery are working at capacity. This means the pressure would drop no more than 10% from compressor pressure at the point of use.

Variables that influence pressure loss due to friction include: pipe diameter, length of pipe, supply pressure, and coefficient of friction for the pipe, which is determined by the material, for example, steel or plastic pipe, plastic or copper tubing, or rubber hose.

Air piping systems can be sized using formulas which are most accurate, or using tables which give a quick approximation. The air flow values in Table 1 are for scfm based on pressure drops of 10% for 1/8 inch through 1/2 inch pipe, or 5% for 3/4 inch through 3 inch pipe. Notice that pipe sizes are nominal Schedule 40 standard pipe size.

| Applied Pressure (psig) | NORMAL STANDARD PIPE SIZE | | | | | | | | | | |
|-------------------------|---------------------------|------|------|-------|-------|-----|--------|--------|------|--------|------|
| | 1/8" | 1/4" | 3/8" | 1/2" | 3/4" | 1" | 1-1/4" | 1-1/2" | 2" | 2-1/2" | 3" |
| 5 | 0.5 | 1.2 | 2.7 | 4.9 | 6.6 | 13 | 27 | 40 | 80 | 135 | 240 |
| 10 | 0.8 | 1.7 | 3.9 | 7.7 | 11.0 | 21 | 44 | 64 | 125 | 200 | 370 |
| 20 | 1.3 | 3.0 | 6.6 | 13.0 | 18.5 | 35 | 75 | 110 | 215 | 350 | 600 |
| 40 | 2.5 | 5.5 | 12.0 | 23.0 | 34.0 | 62 | 135 | 200 | 385 | 640 | 1100 |
| 60 | 3.5 | 8.0 | 18.0 | 34.0 | 50.0 | 93 | 195 | 290 | 560 | 900 | 1600 |
| 80 | 4.7 | 10.5 | 23.0 | 44.0 | 65.0 | 120 | 255 | 380 | 720 | 1200 | 2100 |
| 100 | 5.8 | 13.0 | 29.0 | 54.0 | 80.0 | 150 | 315 | 470 | 900 | 1450 | 2600 |
| 150 | 8.6 | 20.0 | 41.0 | 80.0 | 115.0 | 220 | 460 | 680 | 1350 | 2200 | 3900 |
| 200 | 11.5 | 26.0 | 58.0 | 108.0 | 155.0 | 290 | 620 | 910 | 1750 | 2800 | 5000 |
| 250 | 14.5 | 33.0 | 73.0 | 135.0 | 200.0 | 370 | 770 | 1150 | 2200 | 3500 | 6100 |

Tabled values are flow rates in SCFM. Pressure drop per 100 ft. of pipe is based on 10% of applied pressure for 1/8 in., 1/4 in., 3/8 in., and 1/2 in.; and 5% of applied pressure for 3/4 in., 1 in., 1-1/4 in., 1-1/2 in., 2 in., 2-1/2 in., and 3 in.

Table 1. Maximum recommended air flow through Schedule 40 pipe

Review: 18.1.

What minimum size pipe will deliver compressed air supplied at 80 psig to an air tool rated at 11 scfm 100 feet away with a pressure drop of 10% or less?

- 1/8"
- 1/4"
- 3/8"
- 1/2"
- 3/4"



Outcome 19: Uses formulas to size air receivers to perform various functions.

Receivers serve a number of functions: as a pulsation dampener, as an air reservoir, and as an air conditioner.

As a pulsation dampener, the receiver allows the compressor to supply air at a constant and steady pressure at the outlet of the receiver, even though the pressure varies during each compression cycle.

As an air reservoir, the receiver will supply more air for short periods of time during peak periods of use than the compressor can deliver. Thus, an air system demanding 25 scfm for several minutes may be supplied by a compressor delivering only 20 scfm during the same period of time. Of course there must also be time during the use cycle when air system demand is sufficiently less than 20 scfm so that the compressor may build back an oversupply of air in the receiver for the next time that demand exceeds supply.

The receiver also conditions air by cooling it and removing condensed water through a drain in the bottom. Cool air improves system efficiency. By removing water, components located downstream will be less likely to deteriorate due to the formation of rust and corrosion.

The time during which an air receiver will supply air while the compressor is not operating is given by the formula:

$$\text{Time}_{\min} = [\text{Volume}_{\text{cu-ft}} \times (\text{Max-Pressure}_{\text{psig}} - \text{Min-Pressure}_{\text{psig}})] / (14.7 \times Q_{\text{scfm}}) \quad (\text{Eq. 15})$$

$$T = [V \times (P_{\max} - P_{\min})] / (14.7 \times Q)$$

Review: 19.1.

What capacity in gallons would a receiver have to be to supply 10 scfm of air between 160 psig and 140 psig for 3 minutes? Assume that the temperature remains constant.

- a. 120 gal
- b. 165 gal
- c. 185 gal
- d. 210 gal
- e. 300 gal

Review: 19.2.

A compressor mounted on a 60 gal receiver supplies 12 scfm at 140 psig. If demand is 20 scfm, approximately how long will it be before the pressure drops to 100 psig?

- a. 1.55 min
- b. 2.73 min
- c. 5.60 min
- d. 8.33 min
- e. 15.78 min



Outcome 20: Selects input components to achieve a desired operation in a pneumatic circuit.

Input components are located upstream of the directional control power valve and include the FRL (filter, regulator, lubricator), power lockout valves, start valves, and stop valves.

Figure 24 shows a two cylinder circuit, perhaps a clamp and drill circuit with two (signal output) pilot operated power valves that supply air to two cylinder working components, and two manually operated, spring returned (signal input) pilot control valves, also with separate air supplies.

In Fig. 24, the component in block 1 in the supply line is not identified, but it may be a signal input component. Possibilities are a pressure gauge or pressure light, an FRL, safety lock valve, a two-way manually operated valve, a slow start valve, or timing volume.

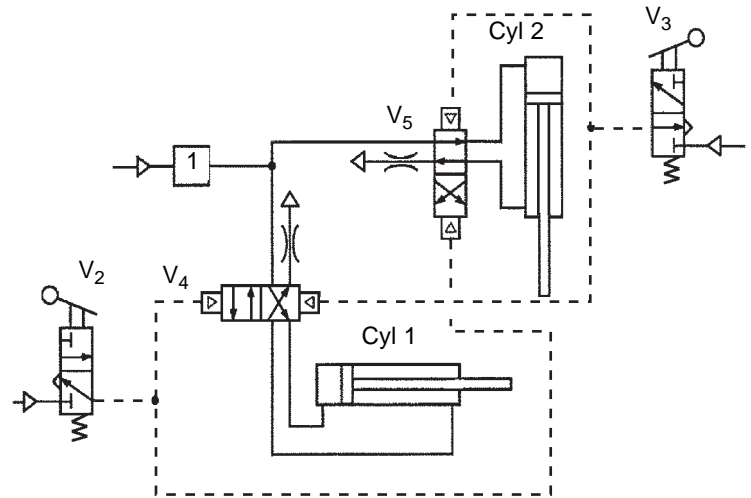

Fig. 24. Two cylinder air circuit.

When the air is turned on, it is likely that the cylinders will move in the direction they were moving when the air was shut off, since the pilot operated power valves are unbiased and would retain the position they had when the air was turned off. If they are in either the extended or retracted position they may move slightly against the end of the stroke, indicating they are under pressure.

Review: 20.1.

What is likely to happen if Valve 2 is not released before Valve 3 is actuated?

- Both cylinders will retract and then extend.
- Cylinder # 1 will retract.
- Cylinder # 2 will extend.
- Both cylinders will stay retracted
- Both cylinders will extend.

Review: 20.2.

Which one of the following components placed in Block 1 will have the least effect on operation of the air circuit shown in Fig. 24?

- Pressure regulator.
- Pressure gauge.
- Lubricator.
- Slow-start valve.
- Two way valve.



Outcome 21: Identifies the most and least important safety considerations in the design of an air circuit.

Safety circuits are required to protect the operator from injury when machines such as presses are under operator control. Typically, they do not affect the force, power, or cycle times of the machine.

Start and stop buttons are located within easy reach of the operator's station. If there is the possibility the operator may become entrapped in the machine, two hand, anti-tie-down, interlock controls are located at the station to position the operator's hands so that they cannot be caught or injured when the press is operated. Mechanical interlocking is another method to prevent operator injury and machine damage.

A manually operated two hand interlock circuit is shown in Fig. 25. Depressing Valve 1 directs air to the blind end of the cylinder, but Valve 2 must also be depressed to allow return air from the rod end to vent to atmosphere. Releasing both valve buttons directs air through Valve 2 to the rod end and retracts the cylinder. The circuit fulfills requirements of a two hand safety interlock circuit, but there are some obvious deficiencies. First, the control valves are acting as power valves and must handle the full air supply to the cylinder. Perhaps more importantly, there are conditions when tying down one valve could endanger the operator.

A second two-hand interlock circuit for an air-oil booster that meets some, but not all, safety requirements is shown in Fig. 26. The circuit uses a large diameter air cylinder to power a bench press hydraulic cylinder with a small diameter. For example, an air cylinder with a 3 inch diameter driving an oil cylinder with a 0.5 inch diameter would generate a pressure ratio of 36 to 1, meaning air at 100 psia would theoretically generate a hydraulic pressure of 3600 psia.

The circuit in Fig. 26 also requires that both valves be depressed in order for the power valve to be pilot operated. Depressing both valves directs the pilot signal to the top pilot of the power valve, causing the air cylinder to extend. Releasing both valves directs air to the bottom pilot of the power valve retracting the air cylinder. If the valves are not depressed or retracted together, the pilot signal is lost and the springs in the power valve return the spool to the center position. Fig. 26 solves the problem of providing a pilot operated power valve to operate the cylinder, but it will complete a partial cycle should one of the hand operated valves be tied down.

In practice, two-hand, anti-tie-down, interlock devices incorporate a delay feature so that both palm buttons must be depressed or released almost simultaneously to advance and retract the cylinder rod. This feature prevents the operator from tying down one valve operator while pressing the other palm button to extend the cylinder in small increments, for example, in order to start a pressing operation, and then reposition the work slightly, which could be highly dangerous.

Review: 21.1.

In Fig. 25, under what conditions would the circuit fail to protect the operator from the cylinder while it is extending?

- a. Tying down V1 and V2.
- b. Depressing V2 but not V1.
- c. Tying down V1 and depressing V2.
- d. Depressing V1 and V2, then releasing V2.
- e. Depressing V1 and V2, then releasing V1.

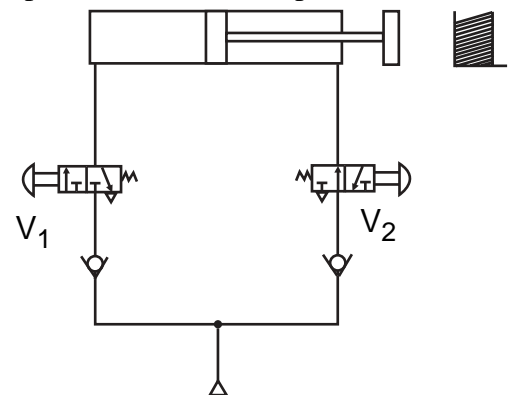

Fig. 25. Two-hand interlock circuit.

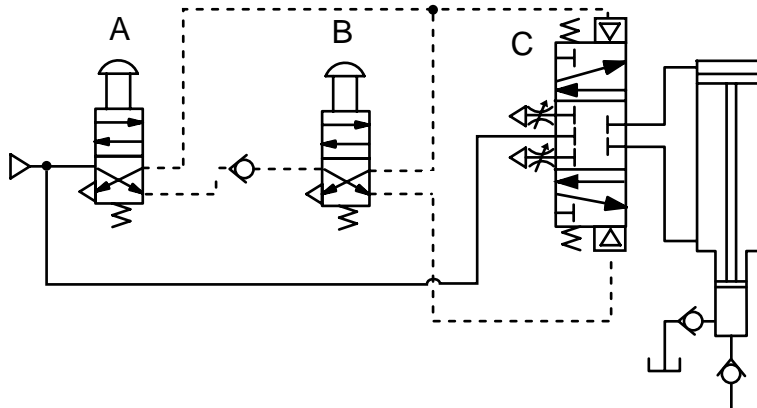

Fig. 26. Two-hand, pilot operated interlock safety circuit.

Review: 21.2.

In the two-hand interlock circuit shown in Fig. 26, if one of the palm buttons is released and then depressed again while the cylinder rod is in mid-stroke advancing, the cylinder rod will:

- a. stop and then retract.
- b. retract and then lock up.
- c. stop and remain stopped.
- d. stop and then continue to advance to the end of the stroke.
- e. continue to advance to the end of the stroke and then stop.

The interlock circuit would be sealed inside a module shown in block 1 in Fig. 27. The presence or absence of signals are received from both palm buttons through metering orifices that time the signal. If both palm buttons are not actuated within a fraction of a second, no pilot signal is sent to shift the power valve. Similarly, if one of the palm buttons is released, the pilot signal also is lost and the cylinder retracts.

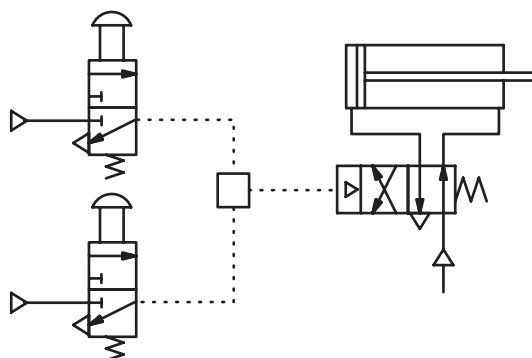

Fig. 27. Two-hand, anti-tie-down, interlock circuit with sealed timing module.

Component Application

Component Application



Outcome 22:

Computes the pressure required to extend a loaded cylinder operating on an incline.

Moving a load on an incline differs from moving a load on the horizontal in that the load is lifted or lowered, and this requires adding potential energy to, or subtracting potential energy from, the system.

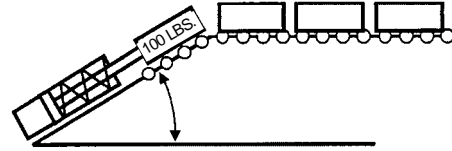

Fig. 28. Friction load being moved up an incline by an air cylinder.

In Fig. 28 for example, assuming the conveyor rollers offer negligible friction, the load is essentially being lifted vertically, even though it is pushed up the incline at some angle by the cylinder. Also, notice that the retraction force offered by the spring in the cylinder must be overcome by air pressure as well when the cylinder rod is extended.

In a 30° right triangle, the relationship of the sides is vertical side length $b = 1$, hypotenuse length $c = 2$ and horizontal side length $a =$ the square root of 3. Computing the value of the distance traveled by the frictionless load along the incline:

$$\sin 30^\circ = a/c = \text{opposite/hypotenuse} = 1/2 = 0.50$$

which says, in effect, that the vertical load of 100 lb travels twice as far along the ramp as it is lifted, and, if friction is neglected, the force required to move the load along the ramp would be half the force required to lift the load outright.

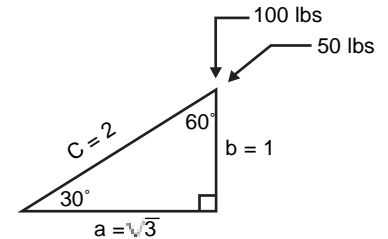

Note that since surface friction is negligible, the first part of the equation will equal zero, and that since the load is being moved up the incline, the second part of the equation has a positive value.

Solving for the force exerted to move the load along the incline using unit values:

$$F_1 \times D_1 = F_2 \times D_2$$

$$F_2 = (F_1 \times D_1)/D_2 = (100 \text{ lbs} \times 1 \text{ unit}) / 2 \text{ units} = 50 \text{ lbs.}$$

Or using trigonometric functions:

$$\text{Total Incline Force}_{\text{lbs}} = (\text{Coefficient of Friction} \times \text{Load}_{\text{lbs}} \times \cos \theta) + (\sin \theta \times \text{Load}_{\text{lbs}}) \quad (\text{Eq. 11})$$

$$\text{TIF} = (C_f \times L \times \cos \theta) + (\sin \theta \times L)$$

Note that the total incline force plus the spring force equals the total load on the cylinder.

Review: 22.1.

In Fig. 28, if maximum spring return force were 25 lbs, what minimum theoretical air pressure would be required to move a 75 lb load up a 30° conveyor ramp using a 2 inch bore cylinder?

- 12 psig
- 20 psig
- 32 psig
- 40 psig
- 45 psig



Outcome 23: Recognizes the advantages and disadvantages of single-acting and double-acting cylinders.

Cylinders and rams are classified as linear actuators. By definition, a ram has a rod diameter equal or greater than more than half the diameter of the cylinder bore. Some pancake cylinders, for example, are technically rams. Most single-acting and double-acting cylinders are set to operate through a full stroke or against stops, rather than to position the load in mid-stroke.

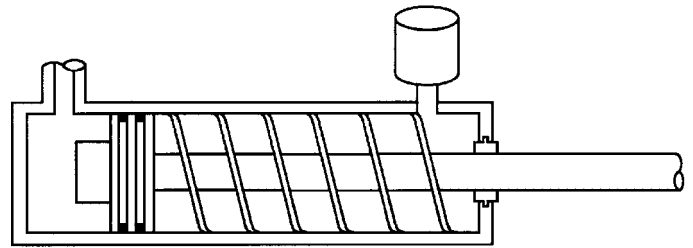

Fig. 29. Single-acting cylinder.

Single-acting cylinders exert a force due to air pressure only in one direction. Springs or gravity provide force in the opposite direction.

Single-acting cylinders have some advantages over double-acting cylinders. They are simple to manufacture. On spring-retracted and spring-extended air cylinders, pressure is only applied to one end. The piston requires only a one way seal. If the cylinder is a spring-retracted type of cylinder, the rod bearing may not include a seal. Since the cylinder is spring offset to one direction, it requires only half the air consumption of a double-acting cylinder. Because the power directional control valve is required to only pressurize and vent the same port, a less expensive 3-way valve rather than a more expensive 4-way directional valve may be used. The air in the opposite end of the single-acting cylinder is vented via a breather.

A disadvantage of single-acting cylinders is the lack of meter-out flow control capability in both directions. Typically, a single-acting air cylinder would have no provision to throttle the vent hole at the rod end, so meter-out control would not be possible. Meter-in control is possible, but would require a constant resistive load on the rod to have much accuracy. Moreover, without metering on the rod end, a single-acting cylinder cannot resist overrunning loads, and have limited load capability in the spring direction.

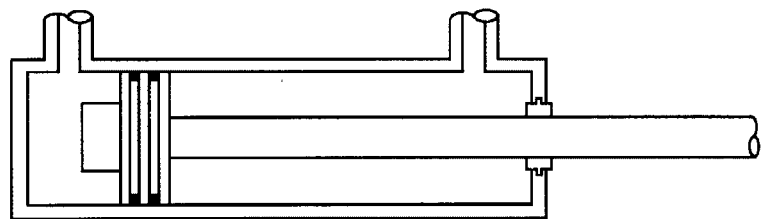

Fig. 30. Double-acting cylinder.

Double-acting cylinders have pressure applied alternately to each side of the piston and therefore have a double piston seal, such as a double cup seal, a double lip seal, or an O-ring, which seals in both directions. A typical double-acting cylinder has a single rod protruding through the rod end of the cylinder. Double rod cylinders have rods that protrude from each end. This would allow the cylinder to move loads in either direction with the same force for a given pressure, pushing or pulling. Double-acting cylinders also come as tandem units, meaning they have more than one piston. If the pistons are hooked together on the same rod but in two pumping chambers, they work in tandem to exert greater force. If the two pistons are not on the same rod, the rods can work in opposite directions, for example, to provide four positions with various combinations of extension and retraction stroke.

Component Application

One major advantage of double-acting cylinders is meter-out capability to stiffen cylinder movement and resist overrunning loads. Double-acting cylinders also offer more possibilities in engineering cylinders into a system because they can be used as single or double rod units, and as tandem units.

Double-acting cylinders have some disadvantages compared to single-acting cylinders. Double-acting cylinders are more expensive to manufacture because a double piston seal and rod seal are required, and a threaded port must be installed in both ends. More expensive four-way valving also is required to pressurize and exhaust alternate ends of the cylinder.

Review 23.1.

Which one of the following is an advantage of a single-acting, gravity returned air cylinder over a double-acting air cylinder?

- a. Less expensive to operate.
- b. Smaller bore can be used.
- c. More noise during operation.
- d. Less wear than double-acting.
- e. Cycle rate is faster during operation.

Review: 23.2.

Which one of the following is an advantage of a double-acting air cylinder over a single-acting cylinder?

- a. Mid-stroke positioning.
- b. Meter-in control of the load.
- c. Controlable force in both directions.
- d. Less expensive to manufacture.
- e. Less expensive valving may be used.

Component Application



Outcome 24: Computes the cfm of air flow to power an air cylinder.

The air flow to power an air cylinder equals the displaced volume of the cylinder at operating pressure, commonly called cfm, converted to scfm. To meet the criteria of scfm (standard cubic feet per minute), atmospheric conditions would have to be corrected to a temperature of 68 °F, 14.7 psia and a relative humidity of 36%. In most industrial applications, temperature and humidity have little effect on the calculations and so may be ignored.

The air volume to power a single-acting cylinder equals the product of the bore area, stroke and cycle rate. If the cylinder is double-acting, the retraction volume is calculated as the volume extending minus the displacement of the rod. Formulas to calculate the cfm for single acting and double acting cylinders are:

$$\text{CFM}_{\text{SA}} = (\text{Piston Area}_{\text{sq-in}} \times \text{Stroke}_{\text{in}} \times \text{Cycle Rate}_{\text{strokes/min}}) / 1728 \text{ cu-in/cu-ft.} \quad (\text{Eq. 16})$$
$$\text{CFM} = (A \times S \times \text{cpm}) / 1728$$

$$\text{CFM}_{\text{DA}} = (\text{Piston Area}_{\text{sq-in}} \times \text{Stroke}_{\text{in}} \times 2 \times \text{Cycle Rate}_{\text{strokes/min}}) / 1728 \text{ cu-in/cu-ft}$$
$$\text{CFM} = (A \times S \times 2 \times \text{cpm}) / 1728$$

Next, the compression ratio must be calculated:

$$\text{Compression Ratio} = (\text{Pressure}_{\text{psig}} + 14.7) / 14.7 \quad \text{CR} = (\text{psig} + 14.7) / 14.7 \quad (\text{Eq. 17})$$

Finally, cfm, which is compressed air, is converted into scfm, which is free air:

$$\text{SCFM} = \text{CFM} \times \text{Compression Ratio} \quad \text{SCFM} = \text{CFM} \times \text{CR} \quad (\text{Eq. 18})$$

Applications often require a cylinder to extend and retract at differing velocities and forces. This affects the air consumption rate of the cylinder. Therefore, many times, the air consumption rate must be figured individually for extension and retraction. In addition, the cycle rate extending may differ during extension or retraction. This is a function of the velocity of the cylinder. Simply averaging the cycle rate of the cylinder by summing the extension and retraction times will not allow one to accurately calculate the actual total air consumption rate. The air consumption of each direction of stroke must be calculated separately, while ignoring the dwell times, if any, as one must solve for the peak of flow rates in each direction.

Review 24.1.

How much air (scfm) is required to power a single-acting air cylinder having a 1.5 inch bore and a 6 inch stroke that cycles 60 times per minute at 100 psig? Neglect the retraction time.

- 0.25 scfm
- 0.37 scfm
- 0.72 scfm
- 1.44 scfm
- 2.88 scfm

Review: 24.2.

An air compressor delivers 10 scfm. At 120 psig, how many times per minute would this cycle a single-acting air cylinder with a 2 inch bore traveling through a 4 inch stroke? Neglect the retraction time.

- 50 cpm
- 75 cpm
- 100 cpm
- 125 cpm
- 150 cpm

Component Application



Outcome 25:

Computes the cylinder bore diameter for a load attached to a cylinder through a system of levers and pulleys. Solves pulley systems for force at the point of application.

Levers are often used in combination with pneumatic cylinders. For example, hold-downs commonly apply first class lever principles, with the cylinder mounted to one end of a lever and the hold down at the other with the pivot located somewhere in between. As a second class lever, the force of the cylinder is increased when the pivot is at one end of the lever while the cylinder is mounted at the other, with the fulcrum located somewhere in between. Finally, as a third class lever, the stroke of the cylinder can be increased. Here the pivot is at one end, the cylinder is mounted at the fulcrum, and the load is applied at the other end of the lever.

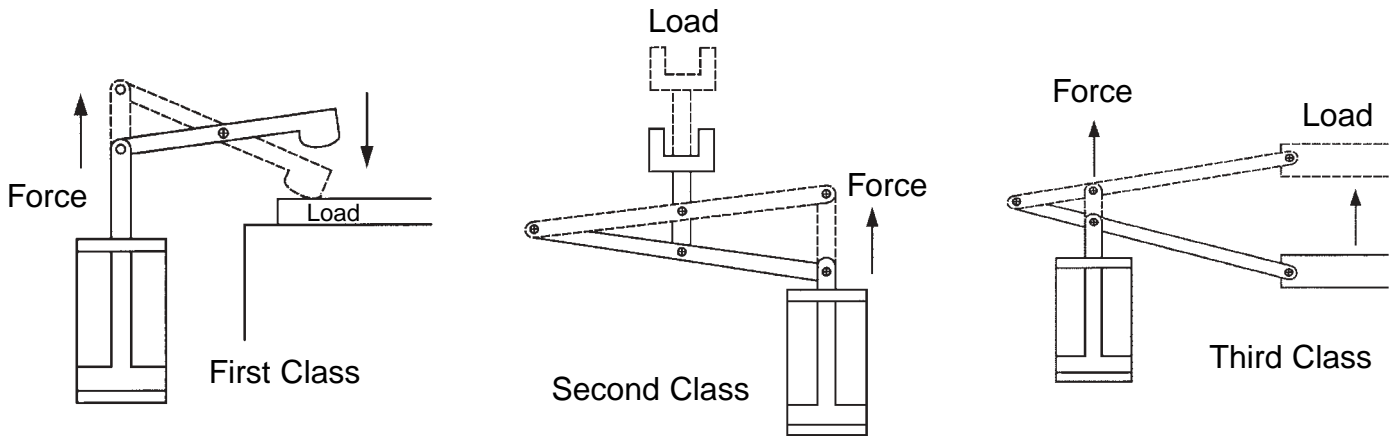

Fig. 31a. Applications of pneumatic cylinders using First, Second and Third class levers.

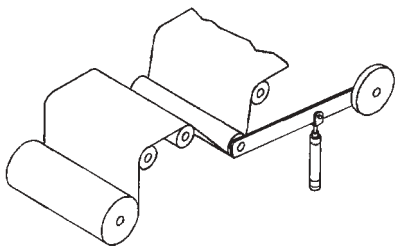

Fig. 32. Web tension system applying lever and pulley principles.

Pneumatic cylinders connected to levers can be combined with pulleys in applications such as the web tensioning arrangement shown in Fig. 32. Here the cylinder applies a tensioning force with air pressure applied to the head end (rod side) of the piston. The cylinder is connected through a third class lever arrangement to the axle of the roller that applies tension to the web. Notice that the action of the roller is similar to a pulley system where the force is applied to move the axle of the pulley rather than the rope.

Lever and pulley problems are solved by working backward from the load. For example, in Fig. 33 a load is suspended across a pulley that is held by an air cylinder through a lever system. Mechanical advantage, which can be defined in either force or distance units, is computed for the pulley part of the system first. Then mechanical advantage of the vertical load is calculated for the lever. Finally, since the cylinder is mounted at an angle to the lever, the vertical force of the load at the clevis must be translated into the force exerted along the axis of the cylinder rod.

Review: 25.1.

Ignoring friction, what theoretical air pressure would be required to hold a load of 50 lb suspended in Fig. 33, if the air cylinder has a 2 inch bore and a 1 inch diameter rod?

- 100 psig
- 128 psig
- 175 psig
- 250 psig
- 316 psig

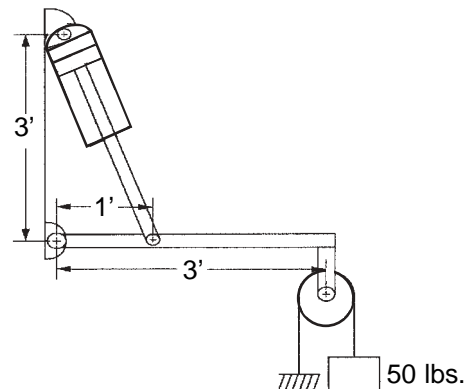

Fig. 33. Jib-boom lever.

Component Application

Cylinders are used with cables and pulleys to reverse direction, to increase lifting force, to tension feed-through systems like conveyor belts, and to shorten and lengthen travel mechanisms.

The simplest use of a pulley is to reverse direction. In Figure 31b.a effort is applied to pull the cable down in order to lift the load. Notice there is one sheave (pulley) and two cables. The pulley axle is stationary, which is important to notice because unless the pulley itself moves linearly there is no multiplication of force. Thus if friction is neglected, an effort of 1000 lb down in one cable results in a force of approximately 1000 lb up in the other cable. The direction is reversed, but there is no multiplication of force.

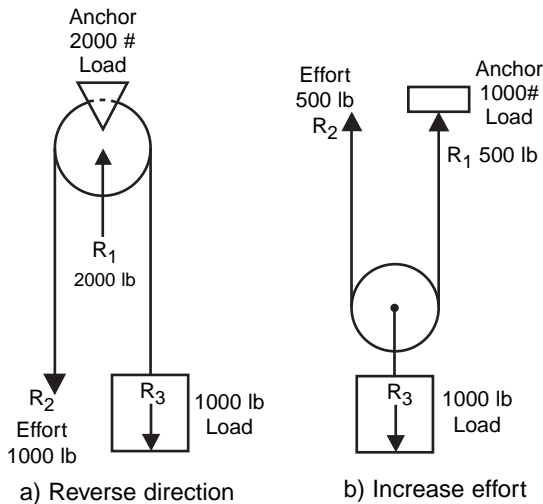

Fig. 31b. Pulley systems to a) reverse direction, b) increase effort.

In Figure 31b.b, there is also one sheave and two cables but one of the cables is anchored while the other cable is pulled up. Pulling the left cable up two lengths will pull the sheave (axle) up one length. Here there is a multiplication of force at the point of application which is at the axle of the sheave, so that an effort of 500 lb in the left cable will result in a 500 lb pull in the right cable, but a 1000 lb pull at the point of application. This leads to an important rule for pulleys:

Pulley Rule 1: Cable pull = Load / # of cables supporting the load.

Force at the point of application can be achieved by adding sheaves to the arrangement. Figure 32c.a illustrates the effort required to lift 1000 lb at the point of application. Notice that Figure 32a is a combination of Figure 31b.a and 31b.b. Multiplication of force is achieved by a movable pulley and two cables, while the change of direction is made with the stationary pulley. Multiplication of effort is achieved at the expense of distance. That is the cable in Figure 32a at the place where the effort is applied, moves twice as far as the load at the point of application.

Figure 32b also illustrates the multiplication of force with a pulley system, but it differs from Figure 32a in that there are three cables between the movable pulley and the effort that is applied. Notice that two of three cables between the movable pulley and the effort around the lower pulley, while the third strand attaches to the axle of the pulley. Three strands between the movable pulley and the effort multiplies the effort three times. Thus, 333 lb of effort results in a lifting capacity of 1000 lb at the point of application.

Pneumatic cylinders are applied to pulley systems in a number of ways. For example, in Figure 32 the cylinder is multiplying the travel distance where the sprocket chain on one side of the sheave is attached to the load at the point of application, and the chain on the other is attached to the anchor. This is the converse of Rule 1.

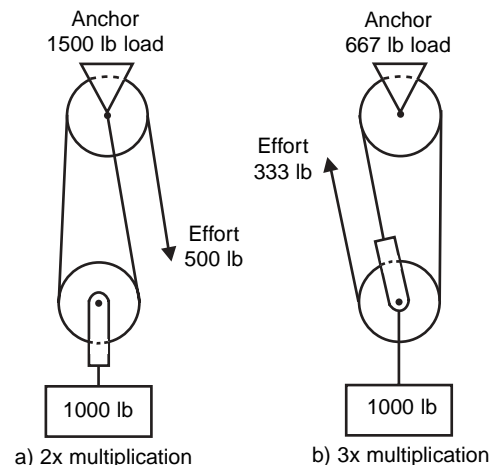

Fig. 32. Multiplication of effort: 2x and 3x multiplication

Rule 2: Total anchor load = cable pull force x # of cables supporting the load

In figure 32 if the load at the point of application is 2000 lb, the applied force at the axle of the pulley would be 4000 lb, while the distance the load is moved would be twice the stroke of the cylinder. In applications like

Component Application

fork lifts, this reduces the cost and stroke of the cylinder, while still providing significant lifting force at the forks.



Outcome 26: Calculates the scfm of air flow to power a single rod cylinder with extension and retraction forces and cylinder times specified.

The flow rate to power air cylinders is typically computed for a specific load on the cylinder rather than from available air pressure at the compressor, which must be higher than is required to power the circuit. Thus, it is the magnitude of the load resistance rather than supply pressure at the compressor that establishes the value of the pressure in the cylinder. Again, cfm refers to compressed air flow (displaced volume) in the cylinder and scfm refers to air flow at standard conditions.

The stroke times extending and retracting are important factors in calculating scfm because they determine cycle rate, which must be known to calculate air consumption.

Solving for scfm to power an air cylinder with extension and retraction forces and cylinder stroke times specified is a four step process:

1. Determine the pressure in each end of the cylinder to move the load.
2. Determine cylinder rod velocity extending and retracting.
3. Solve for cfm using exposed area of the piston and velocity.
4. Convert cfm to scfm.

The pressure to extend and retract a load driven by a double-acting cylinder is computed from the force required in each direction and the area of the piston exposed to pressure ($\text{Pressure}_{\text{psig}} = \text{Force}_{\text{lbs}} / \text{Area}_{\text{sq-in}}$).

Cylinder extension and retraction velocities are calculated from;

$$\text{Velocity}_{\text{ft/min}} = (\text{Stroke}_{\text{in}} \times 5) / (\text{retraction or extension time}_{\text{sec}}) \quad V = (s \times 5) / t \quad (\text{Eq. 19})$$

Displaced cfm extending and retracting at load pressure is computed from:

$$\text{CFM} = (\text{Area}_{\text{sq-in}} \times \text{Velocity}_{\text{ft/min}}) / 144 \text{ sq-in/sq-ft} \quad \text{CFM} = (A \times V) / 144 \quad (\text{Eq. 20})$$

Finally, the SCFM required to power the cylinder is computed from displaced CFM and pressure required to move the load resistance in each direction using Eq. 18 (see page 47).

$$\text{SCFM} = \text{CFM} \times \text{Compression Ratio} \quad \text{SCFM} = \text{CFM} \times \text{CR} \quad (\text{Eq. 18})$$

Finally, the scfm required to power the cylinder is computed from displaced cfm and pressure required to move the load resistance in each direction using Eq. 18 (see page 47).

This information regarding the load pressures and flow rates may be used in calculating the directional control valve C_v (See outcomes 32 and 34).

Review: 26.1.

A double-acting single rod cylinder with a 3 inch bore and a 1 inch diameter rod extends through a 24 inch stroke while producing a 400 lb force, and retracts through the same stroke producing a 600 lb force. If extension time is 2 seconds, and retraction time is 3 seconds, how many scfm are required to power the air cylinder. Friction forces are included in the values given.

- a. 12.29 scfm extending and 12.65 scfm retracting
- b. 12.29 scfm extending and 14.71 scfm retracting
- c. 14.29 scfm extending and 12.65 scfm retracting
- d. 14.29 scfm extending and 15.55 scfm retracting
- e. 14.29 scfm extending and 17.71 scfm retracting



Outcome 27: Calculates the oil flow rate and pressure from a pneumatic intensifier.

Air-oil intensifiers combine advantages of both pneumatics and hydraulics in one system. Air is spongy and lacks precision and stiffness, while hydraulic oil is rigid and allows for precision metering to operate actuators. Air pressure is limited to about 150 psig, while commonly available hydraulic components can be operated at pressures to 3000 psig and above.

Air systems, consisting of a compressor and loop distribution system, exist in most shops. A number of air-oil systems are available as off-the-shelf units or are inexpensive to fabricate. Perhaps the simplest air-oil system is an automotive lift that applies air pressure from a tank directly to a large diameter ram that lifts a pan hoist. Here air pressure acts directly on a ram large enough that 150 psig against an 8 in. diameter ram (approximately 50 in.²) will lift a theoretical weight of more than 7500 lb. This system is slow and cumbersome because air transfer takes time and a large storage tank is necessary for the fluid, compared to modern lift systems that use high pressure hydraulics and small power units.

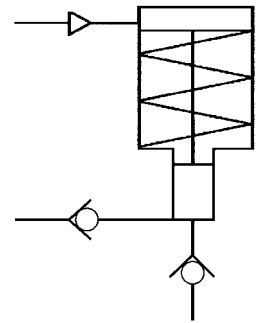

Fig. 34. Air-oil intensifier.

More common are portable bench press units and hydraulic intensifiers that use a combination air-oil cylinder to multiply air pressure to a hydraulic pressure of 3000 psig and higher. Because machinery is simplified, initial and operating costs are low compared to hydraulic units that would require a more expensive power pack (motor, pump, reservoir and valving), in addition to hydraulic hoses and plumbing.

In a typical air-oil intensifier (Fig. 34), a large diameter air piston is connected rigidly to a small diameter oil piston. The oil pressure available at the outlet of the intensifier is a function of the air pressure and ratio of the area of the large air piston to the area of the small oil piston. The balance of pressure and force for the intensifier is given by

$$\text{Air Pressure}_{\text{psig}} \times \text{Air Area}_{\text{sq-in}} = \text{Oil Pressure}_{\text{psig}} \times \text{Oil Area}_{\text{sq-in}} \quad P_{\text{Air}} \times A_{\text{Air}} = P_{\text{Oil}} \times A_{\text{Oil}} \quad (\text{Eq. 21})$$

Since the pistons are connected together, the strokes of the air cylinder and oil cylinder are equal.

Solving for SCFM to power an air-oil accumulator where air cylinder and intensifier cylinder bore diameters are given, and the oil flow rate is specified is a five step process:

1. Determine the pressure in the air cylinder to generate the required oil pressure in the intensifier. (Eq. 21)
2. Determine cylinder rod cycle rate to supply the specified GPM oil flow. (Eq. 22)
3. Solve for CFM flow from air cylinder bore, stroke and cycle rate. (Eq. 16, Choose from SA or DA)
4. Calculate the compression ratios. (Eq. 17)
5. Convert CFM to SCFM. (Eq. 18)

When the flow rate of the oil cylinder is given in GPM and the cylinder area and stroke are given in inch units,

$$Q_{\text{gpm}} = (\text{Area}_{\text{sq-in}} \times \text{Stroke}_{\text{in}} \times \text{Strokes/Minute}) / 231 \text{ cu-in/gal} \quad Q = (A \times S \times \text{SPM}) / 231 \quad (\text{Eq. 22})$$

Component Application

To solve for the cfm, choose the appropriate version of formula 16 depending on whether the air cylinder is single-acting or double-acting.

$$\text{CFM}_{\text{SA}} = (\text{Piston Area}_{\text{sq-in}} \times \text{Stroke}_{\text{in}} \times \text{Cycle Rate}_{\text{strokes/min}}) / 1728 \text{ cu-in/cu-ft (Eq. 16)}$$

$$\text{CFM}_{\text{SA}} = (A \times S \times \text{cpm}) / 1728$$

$$\text{CFM}_{\text{DA}} = (\text{Piston Area}_{\text{sq-in}} \times \text{Stroke}_{\text{in}} \times 2 \times \text{Cycle Rate}_{\text{strokes/min}}) / 1728 \text{ cu-in/cu-ft}$$

$$\text{CFM}_{\text{DA}} = (A \times S \times 2 \times \text{cpm}) / 1728$$

Finally, CFM for the extension part of the stroke is converted to SCFM using Eq. 18 (see page 47).

$$\text{SCFM} = \text{CFM} \times \text{Compression Ratio}$$

$$\text{SCFM} = \text{CFM} \times \text{CR}$$

$$\text{(Eq. 18)}$$

Review: 27.1.

An air-oil intensifier with a 4 inch diameter bore and 2 inch stroke powers an oil piston intensifier with a 0.5 inch diameter bore. What would be the maximum oil pressure from air supplied at 140 psig? (Refer to Fig. 34)

- 1120 psig
- 8960 psig
- 9900 psig
- 11,200 psig
- 18,860 psig

Review: 27.2.

A single-acting piston (spring return) type air-oil intensifier with a 3 inch diameter bore and 1.5 inch stroke powers an oil piston intensifier with a 0.5 inch diameter bore. How many scfm of air would be required to deliver 1/4 gpm oil at a pressure of 4000 psig? (Ignore the pressure required to compress the return spring.)

- 8.56 scfm
- 10.31 scfm
- 18.22 scfm
- 20.63 scfm
- 24.65 scfm

Component Application



Outcome 28: Calculates the torque output from a rack and pinion gear mechanism driven by two air cylinders.

Rotary actuators are used for rotating, bending, oscillating, transfers and flipovers, positioning, dumping, and indexing operations. They rotate from a few degrees to several revolutions.

The rotary actuator diagram shown in Fig. 35 uses two air cylinders, supplied from the same source, and a rack and pinion mechanism to exert a torque on the shaft in each direction, thus doubling shaft torque.

$$T_{lb-in} = \text{Pressure}_{psig} \times \text{Area}_{sq-in} \times (PD_{in}/2) \times \# \text{ of Effective Cylinders}$$

$$T = P \times A \times (PD/2) \times \#C \quad (\text{Eq. 23})$$

The torque output from the motor shaft is a function of the pitch diameter, cylinder bore, and air pressure such that:

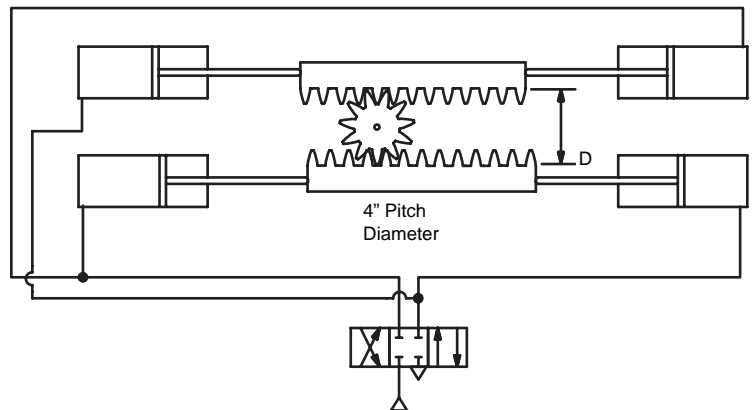

Fig. 35. Rack and pinion rotary actuator.

Review: 28.1.

If the rotary actuator shown in Fig. 35 operates on 100 psig air, what diameter pistons would be necessary for the motor to exert a theoretical torque of 150 lb-ft?

- a. 1.69 inches
- b. 2.39 inches
- c. 2.88 inches
- d. 3.38 inches
- e. 4.50 inches

Component Application



Outcome 29: Calculates the kinetic energy required to stop a load with a shock absorber.

It is common practice to position shock absorbers to cushion loads attached to air cylinders rather than to subject the air cylinders to shock loading. This practice allows sizing the cylinder to move the load and sizing the shock absorber to stop moving the load within the required distance.

Kinetic energy is given by the formula:

$$KE_{ft-lb} = (W_{lb} \times V_{terminal}^2) / 2g \quad \text{where } g = 32.2 \text{ ft/sec} \quad KE = (W \times V_t^2) / 2g \quad (\text{Eq. 24})$$

Of these factors, only the terminal velocity will be an unknown factor in the problem.

Consider a crate, like that shown in Figure 36, rolling into a shock absorber mounted on a conveyor. Since the starting velocity is zero, if the crate accelerates uniformly, the average velocity of the crate may be calculated: The average velocity is the distance traveled divided by the time it takes to travel the distance:

$$V_{average} = \text{Distance}_{ft} / \text{time}_{sec}$$

Since the starting velocity is zero, the average velocity may also be expressed by the equation:

$$V_{average} = (V_{terminal} - V_{initial}) / 2 = (V_{terminal} - 0) / 2$$

Since the initial velocity is zero, the last equation may be rewritten as:

$$V_{average} = V_{terminal} / 2$$

It follows that:

$$V_{terminal} = 2 \times V_{average} = 2 \times \text{Distance}_{ft} / \text{time}_{sec}$$

Therefore:

$$V_{terminal} = 2 \times \text{Distance}_{ft} / \text{time}_{sec}$$

$$VT = 2D / t \quad (\text{Eq. 25})$$

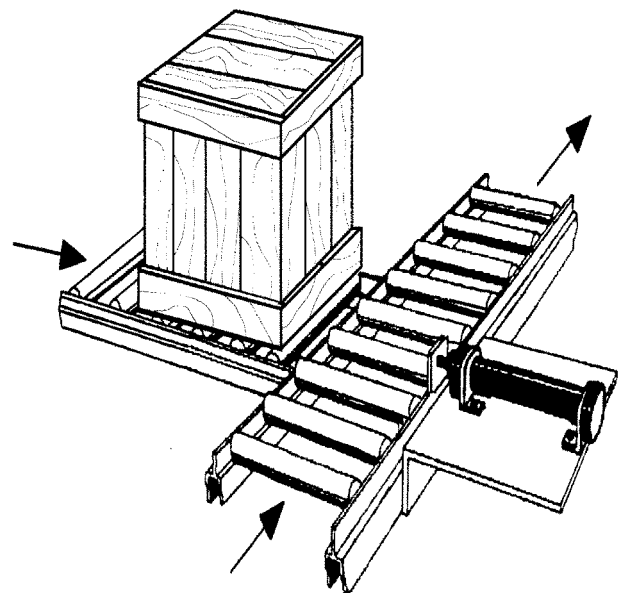

Fig. 36. Kinetic energy of a rolling object.

Review: 29.1.

If the crate in Fig. 36 weighs 40 lbs and it takes 3 seconds to slide down the 10 ft ramp onto the main conveyor, how much kinetic energy must be absorbed by the shock absorber? Assume the load accelerates uniformly onto the conveyor.

- a. 5.59 ft-lb
- b. 27.63 ft-lb
- c. 60.64 ft-lb
- d. 72.58 ft-lb
- e. 97.53 ft-lb



Outcome 30: Recognizes the characteristics of stop tubes and cushioning devices.

There are a number of ways to protect air cylinders from shock loading and side loading: incorporating positive stops in the design of the machine, stiffening the action of the air cylinder by coupling it to a hydraulic cylinder, incorporating shock pads and bumpers, and using stop tubes.

Because the operation of air cylinders typically requires full extension and full retraction, and often accelerate throughout the stroke, they are prone to bottoming.

Positive stops in machine members keep the piston away from the cap and head ends, but if these are not incorporated in the design, internal Buna N or external urethane bumpers (shock pads) are commonly added as an option to set stroke length and cushion impact. For example, quarter inch thick external bumpers can be fitted over the cylinder rod or guide shafts to set the stroke and prevent overstroking that is possible with heavy loads and high velocities, which could be as much as 70 in/sec for loads to 5 lbs, and 20 in/sec for loads over 100 pounds. Adjustable air cushions are another option offered by some manufacturers.

An air-oil cylinder assembly, like that shown in Fig. 37, uses an air cylinder to provide the power, coupled to an oil cylinder to stiffen actuation. The oil portion of the cycle regulates velocity by throttling oil from one end of the cylinder to the other end with a metering orifice. Notice that extension and retraction metering are independent so that each orifice can be set for varying conditions. These could include differences in load as well as differences in oil volume between the two sides of the piston.

Stop tubes, which are common in hydraulic cylinders, may be used to reduce the tendency for rod misalignment by shortening the stroke. This prevents the rod from cocking at the end of the stroke.

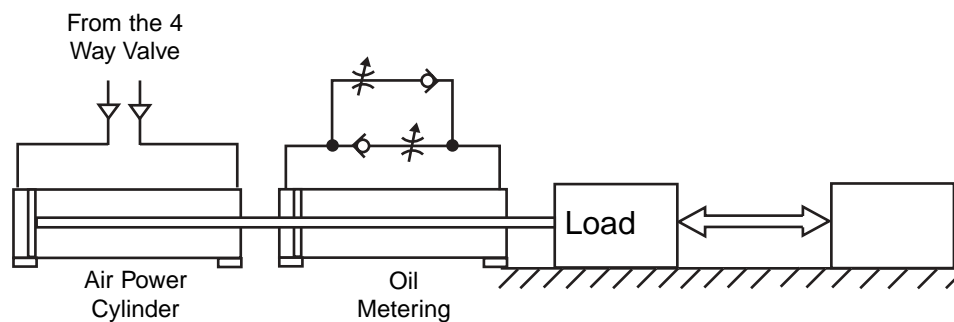

Fig. 37. Air-oil coupled cylinder.

Review: 30.1.

Which method of reducing shock could build pressure surges in the cylinder?

- Stop tube.
- External bumper.
- Internal shock pad.
- Adjustable air cushion.
- Air-oil cylinder arrangement.

Component Application



Outcome 31:

Associates cylinder designs with their applications.

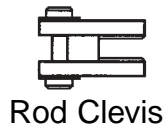

Rod Clevis



Nose Mount Nut

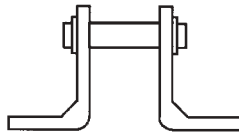

Pivot Bracket



Universal Mounting Bracket

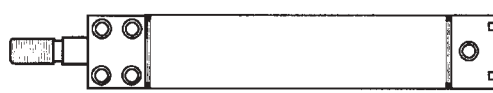

Block Mount

Cylinders are linear actuators used to exert a force through some given stroke distance. It is a generally accepted rule that cylinder rods should not be subjected to side loads, though as discussed in Outcome 2, a cylinder bearing can accept a certain amount of side loading. The less the side loading, the less the wear will be on the rod bearing, dynamic seal, and the rod surface.

Cylinders are available in a wide

variety of mounting styles. Usually, the design of the machine dictates the mounting that must be used, though sometimes more than one mounting style may be adapted. For example, when the machine members only move in one plane of motion (out and back), there are many types of rigid mounts available such as side tapped, end lugs, side lugs, centerline lugs, blind end flange, and rod end flange mounts. In applications where the cylinder must be free to pivot as the machine members move in relationship to each other, there are front, mid, and end trunion mounts, as well as rear clevis mounts.

When the application allows for the use of a rigidly mounted cylinder, care must be given to ensure that the moving machine member is well guided so that a side load is not induced on the cylinder rod bearing. If the load has a tendency to twist or corkscrew, additional means to support the load can be added by using parallel shafts mounted on precision bearings to stabilize the linear travel, thereby providing a guided path for the cylinder rod. One method of accomplishing this task is to attach the rod end to a machine member that is guided in one or more dovetailed ways, gibs, or posts (as found in a four-post press). Another solution would be to build a guided rod cylinder mounting in which the cylinder is mounted to a main support. This support would include suitable sized linear bearings. The cylinder rod would in turn be mounted to a plate, the travel of which is supported by rods that are guided by the linear bearings located in the main support. Refer to Figure 39.

In all applications, rod bending in the form of sagging or jackknifing must be considered. If the stroke is fairly long, and the thrust is great enough, the rod may bend if it is too weak. Bending due to high thrust is generally more of a problem in hydraulic applications due to the high pressures available with which to develop force. Jackknifing is a common problem with clevis and rear trunion mounted cylinder applications. This is because the effective lever can easily become very long, increasing the reaction force to which the rod bearing is subjected. A solution to reduce the length of the effective lever would be to use a front trunion mount. This may not be practical, and it is also more expensive to construct the machine mounting for a trunion mounted cylinder than for a rear clevis mounted cylinder. In order to reduce the reaction

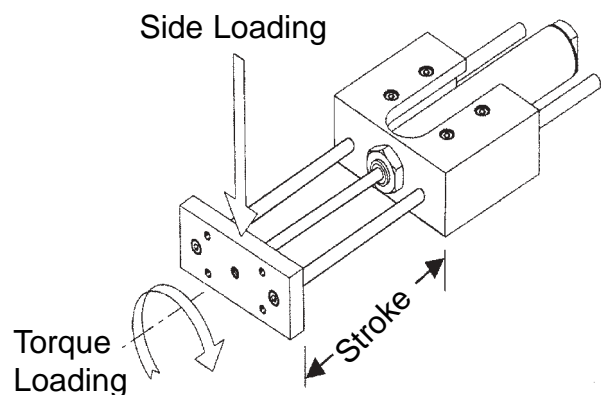

Fig. 39. Guided shaft cylinder mounting.

force on the rod bearing, a stop tube may be installed. The stop tube prevents the cylinder piston from approaching the rod bearing, increasing the effective length of the lever inside the cylinder, thereby offsetting the length of the lever outside of the cylinder. In order to retain the amount of effective stroke, generally referred to as the “net stroke,” the “gross stroke” must increase by the length of the stop tube, and the overall length of the cylinder increases by the same length. Sometimes, merely increasing the diameter of the cylinder rod, with a consequent increase in the length, and therefore the load capacity, of the rod bearing, will allow negate the need for a stop tube. Keep in mind though, that for a given cylinder bore and stroke, when the rod diameter is increased, the length of the cylinder also increases.

Most cylinder manufacturers include application guidelines in their catalogs that cover mounting considerations and the rod strength as it applies to rod sagging and jackknifing. When in doubt about a particular application, it would be wise to forward the operational and mounting parameters to the manufacturer to have them sign off on the application.

Finally, ensure that the cylinder is not subjected to loads caused by insufficiently stiff machine members. This is generally beyond the control of a pneumatic specialist, yet it is incumbent upon the specialist to caution the machine designer about this very important point.

Rodless cylinders have their own set of application considerations that depend on their individual means of construction. An advantage of rodless cylinders over cylinders with rods is that the overall length of a rodless cylinder is not much greater than its useful stroke. This feature allows for compact installations that may be well suited in certain applications that fit within the various limitations and disadvantages of rodless cylinders. Again, when applying rodless cylinders, it is advisable to have the manufacturer review and sign off on certain applications.

Review: 31.1.

Which cylinder design is most effective in supporting side loading?

- a. Guided rod mount.
- b. Nose mount.
- c. Block mount.
- d. Universal mount.
- e. Clevis and pivot mount.



Outcome 32: Calculates the C_v for an air valve from pressure, flow and temperature conditions.

Traditionally, directional control air valves have been sized by port size, but this has been shown to be inaccurate from size to size, and from manufacturer to manufacturer. Consequently, this practice made it difficult to predict how much air a particular valve size would flow, and it did not allow comparisons between valves from different suppliers.

Flow coefficients standardize the flow capacity of air valves. This means that air valves from two manufacturers that have the same C_v will flow the same scfm of air under the same condition.

C_v values are also proportional to the scfm that an air valve will flow. This means that an air valve with a $C_v = 2$ will flow twice the scfm that a valve will that has a $C_v = 1$.

Valve applications can be made from flow charts that solve for the C_v when the inlet port pressure and air flow are known, or from orifice formulas that have been modified to include C_v . Arriving at computed values of C_v is slower because calculations are required, but they are more accurate because valves for the inlet pressure, pressure drop, flow rate, and temperature approximate existing conditions, rather than the conditions given by the manufacturer.

The formula preferred by the FPS to derive C_v for an air valve is:

$$C_v = \text{Flow}_{\text{scfm}} / 22.67 \sqrt{T_{\text{Rankine}} / [(P_{\text{in}} - P_{\text{out}})K]} \qquad C_v = Q / 22.67 \sqrt{T / [(P_{\text{in}} - P_{\text{out}})K]}$$

Where: $K = P_{\text{out}}_{\text{psia}}$ if $\Delta p \leq 10\%$ of $P_{\text{max}}_{\text{psia}}$
 $K = (P_{\text{in}}_{\text{psia}} + P_{\text{out}}_{\text{psia}}) / 2$ if $\Delta p = 10$ to $< 25\%$
 $K = P_{\text{in}}_{\text{psia}}$ if $\Delta p \geq 25\%$ and $\leq 53\%$

(Eq. 26)

Note: $^{\circ}\text{Rankine} = ^{\circ}\text{Fahrenheit} + 460$

Review: 32.1.

An air valve delivers 35 scfm at 70 °F with a supply pressure of 80 psig. If the valve has an 8 psig pressure drop, what is the C_v for the valve?

- a. 1.08
- b. 1.29
- c. 1.35
- d. 1.40
- e. 1.48



Outcome 33:

Recognizes that the critical (sonic) velocity through an orifice is reached when the downstream pressure is 53% of the upstream pressure, and at the critical velocity, increasing the pressure drop across the orifice will not increase the air flow.

While approximate C_v values determined from formulas or charts and graphs are useful as a guide to make valve selections, they have obvious limitations. Both calculated values and values read from charts and graphs are for standard conditions and a constant pressure drop. Neither of these conditions exist in the workplace.

The value of the constant K in Eq. 27 depends upon the pressure drop across the valve. For pressure drops greater than 25% of the supply pressure, $K = p\text{-in}$, but in no case can the pressure drop be greater than $0.53 \times p\text{-in}$, because at this point the critical velocity is reached, the velocity may become sonic, and the C_v formula is no longer valid. What this means in practical applications is that $0.53 \times p\text{-in}$ (the upstream pressure) is the limiting factor for passing air through a valve to an actuator. Tests have shown that when the critical velocity is reached, the flow rate continues to increase slightly, but at an extremely reduced rate.

More typical of the selection process is to calculate a C_v value for the application, verify a range of pressures within which a valve from a given manufacturer will provide sufficient air at an economical price, and then over-size the valve if cycle rates (air flow) are expected to go higher, or if pressure is likely to fall below values used in the calculation of C_v .

Review: 33.1.

The upstream pressure against an orifice is 125 psig. If the flow rate is 20 scfm at 60 psig, what happens to the flow if the downstream pressure decreases to 40 psig?

- a. Is cut in half.
- b. Decreases linearly.
- c. Increases slightly.
- d. Increases linearly.
- e. Doubles.

Component Application



Outcome 34: Calculates the C_v to size a directional control (power) valve for an air motor.

Air motors that power fans, hoists, winches, pumps and concrete vibrators are manufactured to operate at pressures of 80 PSIG and up. In fractional sizes to 1 hp, air motors consume about 35 scfm per brake horsepower (bhp). In sizes between 1 hp and 5 hp consumption is reduced slightly to 30 scfm per bhp.

Air consumption by an air motor is determined by the pressure, displacement and rpm. Unlike hydraulic motors, where the pressure is determined by the load on the shaft, the pressure on the air motor can be determined by a number of factors, including the load resistance and throttling at the control valve to regulate rpm. For a constant load, the speed of an air motor is controlled by regulating the pressure.

If the speed of the air motor is controlled by the pressure against a given load resistance, the control valve is sized to offer the minimum restriction for the conductor size. On the other hand, control valves that are installed in the housing of rotary tools regulate both air flow and pressure to drive a work spindle. For example, die grinders, sanders and assembly tools, operate from wide open under no load, to stall speed at full torque.

Eq. 26 is used to derive C_v for an air valve that offers the least restriction. The calculation is used the same as for sizing valves for cylinders.

$$C_v = \text{Flow}_{\text{scfm}} / 22.67 \sqrt{T_{\text{Rankine}} / [(P_{\text{in}} - P_{\text{out}})K]} \qquad C_v = Q/22.67 \sqrt{T / [(P_{\text{in}} - P_{\text{out}})K]}$$

Where: $K = P_{\text{out}}_{\text{psia}}$ if $\Delta p \leq 10\%$ of $P_{\text{max}}_{\text{psia}}$
 $K = (P_{\text{in}}_{\text{psia}} + P_{\text{out}}_{\text{psia}}) / 2$ if $\Delta p = 10$ to $< 25\%$
 $K = P_{\text{in}}_{\text{psia}}$ if $\Delta p \geq 25\%$ and $\leq 53\%$

(Eq. 26)

Note: $^{\circ}\text{Rankine} = ^{\circ}\text{Fahrenheit} + 460$

Review: 34.1.

A directional control valve directs air to a bi-directional motor which consumes 30 scfm at 90 psig. If the air is available at the valve inlet at 100 psig and 90° F, what is the required valve C_v ?

- a. 0.398
- b. 0.492
- c. 0.702
- d. 0.928
- e. 0.959

Air Compression and Preparation



Outcome 35: **Calculates the required compressor delivery capacity from the system demand, pressure and duty cycle.**

Air compressors are sized by the amount of free air they pump (scfm). Free air is at zero psig. Air tools, cylinders, and air motors are rated at the amount of air that they consume at their operating pressure, which is stated in cfm at some given pressure. Another way to look at this is to consider the delivery of an air compressor as the airflow rate entering the intake of the compressor, rather than the air flow rate exiting the outlet of the compressor. Air flow entering the compressor is measured at zero psig (atmospheric pressure), while the air flow exiting the compressor is at some higher pressure, e.g., 100 psig.

Compressing air to pressures beyond about ten percent above the required pressure is considered to be a needless expense. Generally, a compressor is oversized by some factor. This allows for a future increase in demand for air as the plant size or the plant production rate increases. The compressor cannot be sized to supply less than the average air consumption rate, because no matter how large the receiver is, the compressor will not be able to recover. The average air consumption rate is typically thirty to sixty percent of the peak air consumption rate. Once the average air consumption rate is determined, the compressor is sized to accommodate future plant expansion, as history indicates that most systems are expanded by twenty-five to fifty percent after they have been placed into service. This means that the compressor must operate at less than a 100% duty cycle. For example, if the compressor is sized to produce twice the air requirement of the plant, then it will operate at a 50% duty cycle. In other words, the compressor will keep up with the plant air demand while operating only half of the time. Air receivers must be sized to accommodate the peak air consumption rate (see Outcome 19).

Duty cycle and cycle control are also important. The duty cycle is the percentage of time the compressor is intended to operate. A fifty percent duty cycle would have the compressor operating half the time air was being consumed. The air receiver would provide makeup airflow during times of peak air consumption. If the compressor uses stop-start controls, a differential pressure switch is used to control the motor starter. The motor will be shut off when the high-pressure set point is reached, and the motor will start again when the pressure drops to the low-pressure set point. If the compressor uses continuous control, the motor continues to run all of the time. On reciprocating machines (piston compressors) the unloading valve will hold the compressor intake valve open and air will not be compressed. On screw and rotary vane compressors, the inlet valve can be either on or off, and on larger machines, the inlet valve may be modulated, controlling the amount of air drawn into the compressor.

The required size of a compressor may be calculated from the following:

$$\text{Average System Demand}_{\text{cfm}} = (\text{Compressor Delivery}_{\text{scfm}} \times \text{Duty Cycle}_{\%}) / (\text{Compression Ratio} \times 100_{\%})$$
$$\text{ASD} = (\text{CD} \times \text{DC}) / (\text{CR} \times 100) \quad (\text{Eq. 27})$$

Standard conditions of 14.7 psia, 68° F, and 36% relative humidity are assumed.

The air consumption requirements of a component, a machine, or a system, may be specified in either cfm or scfm. Thus, care must be taken when analyzing and calculating the amount of air flow required.

Review: 35.1.

The average air consumption rate of a system is 25 cfm at 100 psig. Assume that the system includes an air receiver that adequately supplies air during times of peak air consumption. What size compressor, in scfm, is needed if the compressor is to operate at a 60% duty cycle?

- a. 69 scfm
- b. 117 scfm
- c. 325 scfm
- d. 195 scfm
- e. 42 scfm

Air Compression and Preparation



Outcome 36: Associates compressor components with their functions.

Compressors are pumps that raise the air pressure, condition the air, and store the compressed gas in the receiver for use throughout the system. In its simplest form, a single stage positive displacement air compressor uses a piston to draw air in through an inlet filter and an inlet valve, compresses it in the cylinder, and forces the compressed air into a receiver through a check valve that prevents back flow to the compressor. The inlet filter protects the compressor from particles larger than 80 microns that may cause wear to rings and other close fitting parts. The practical limit of pressure for single stage piston compressors is 80 to 150 psig, at which point a compression ratio of about 11 to 1 limits pumping efficiency.

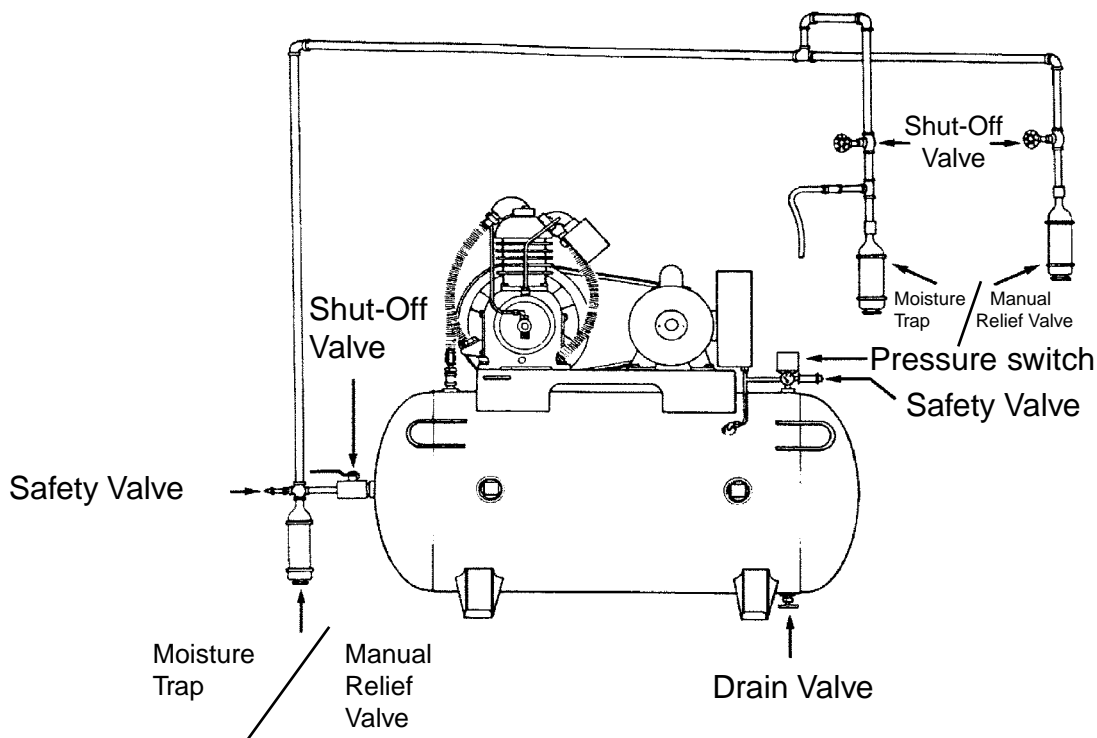

Fig. 40. Compressor mounted on a receiver.

In addition to the draincock, receiver accessories include a pressure safety valve constructed to ASME standards to protect the receiver from exploding from over pressure. These safety valves have a ring that is manually pulled to periodically test valve action to check that it is free and unobstructed.

During compression, air molecules become compressed and generate heat, which in turn reduces the volumetric efficiency of the compressor. Losses are kept to a minimum by dissipating the heat through fins on the compressor. The compressed gas also cools in the receiver.

Two stage compressors can compress air to pressures in excess of 250 psig. A large first stage piston feeds compressed air into a smaller second stage piston. To improve volumetric efficiency, an intercooler, consisting of a finned tube cooled by the flywheel fan, cools the compressed air between stages. The heat of compression is transferred from the hot air to the core tube, to the fins, and then to atmosphere. Cooling is aided by the flywheel fan, which also cools the case, cylinder and head of the compressor.

Air Compression and Preparation

Water vapor, which is held naturally in air, is compressed with the air and remains in suspension until the air cools. For example, 1000 cu-ft of saturated air at atmospheric pressure and 80 °F contains about 1.58 pounds of water. Compressing that air to 100 psig and then cooling it back to 80 °F will reduce the moisture content by about 90% to about 0.2 lb. This means that if unconditioned compressed air is sent downstream it will contaminate the piping system along the way with liquid water that drops out of suspension entering air tools and machinery. For this reason the water must be removed. An aftercooler attached to the compressor outlet will remove most of the water before it gets into the piping system. The receiver conditions air the same way. As air cools in the receiver, water condenses, falling to the bottom of the reservoir where it is drained off. In practice, aftercoolers placed immediately downstream of a compressor can remove approximately 85% of the moisture that passes through the compressor. Other methods used to further reduce the water content in compressed air include refrigeration or desiccants such as activated alumina.

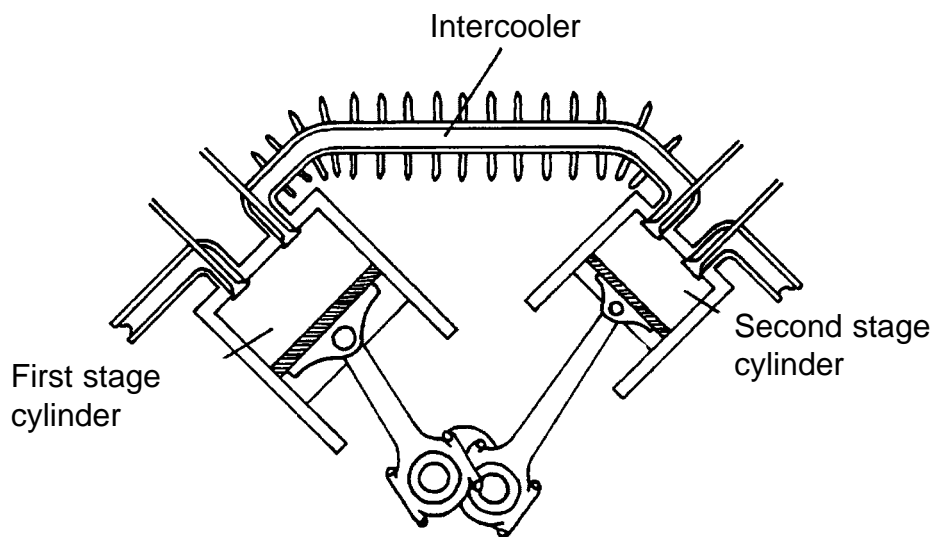

Fig. 41. Two-stage compressor with intercooler.

Review: 36.1.

Which one of the following components removes the most water from compressed air?

- a. Intercooler
- b. After cooler
- c. Receiver
- d. First stage
- e. Inlet filter



Outcome 37: Identifies characteristics of air filter elements.

Air line filters are sized to handle the flow requirements of air circuits and air tools. They are placed in the supply line and engineered to handle full air pressure. Usually, they are incorporated in the FRL (filter, regulator, lubricator) if machinery requires pressure regulated and lubricated air. All three units will be equipped with transparent polycarbonate sight bowls to permit visual inspection. Where bowl cracking and rupture are problems, perforated metal guards are fitted over the bowl to protect personnel from injury.

Filter elements are available in felt, paper, cellulose, metal, plastic screening, metal ribbon, sintered bronze, sintered plastic, glass fiber and cloth. Filter elements are rated for minimum particle size which can be removed from the air stream. Both NOMINAL and ABSOLUTE ratings are used, making comparisons difficult.

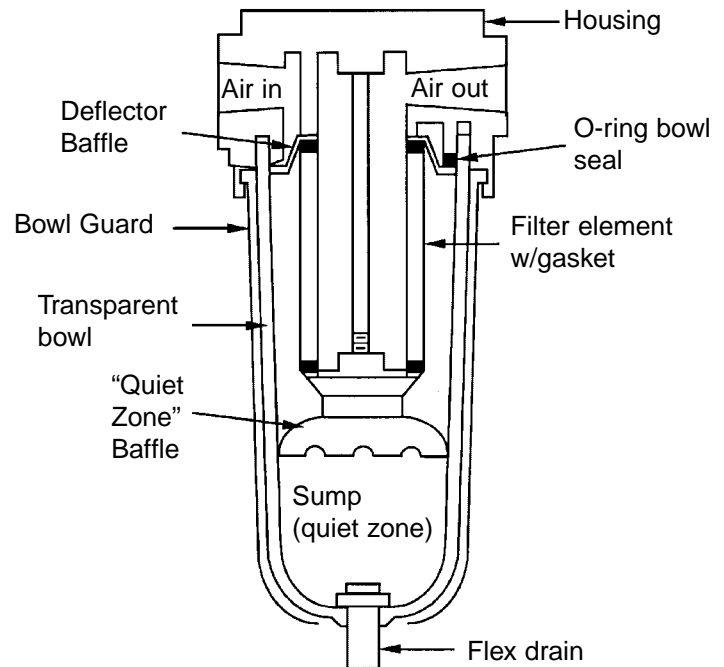

Fig. 42. Filter for compressed air.

FRL units are located typically at each air drop to condition the air just before it reaches the component. For most industrial applications, filter elements are rated at 5 microns. A micron is equal to one millionth of a meter.

1 micron = 0.000 001 meter

Since:

1 meter = 100 cm x 1 in./2.54 cm = 39.370078 in.

1 micron = 0.000 001 meters x 39.370 078 in./meter = 0.000 039 3 in.

By comparison, the lower limit of visibility is about 40 microns.

As micrometer size decreases, the physical size of the filter must be increased to provide the same air flow at the same pressure drop. This is because finer filtration results in a higher pressure drop for the same size filter at a given flow rate.

The first cleaning action in a filter is caused by swirling the air to remove heavy particles and water that separate and collect at the bottom of the filter. If the filter does not remove the water first, it cannot remove particulates. Air is then passed through the porous media. The porous media strains out smaller particles, with the degree of filtration dependent upon the pore size. Periodically, the bowl is drained to remove the water.

Review: 37.1.

If a filter with a 40 micron rating is replaced with an element that has an 80 micron rating, the:

- a. Downstream pressure will drop.
- b. Upstream pressure will increase.
- c. Downstream flow will drop.
- d. Downstream flow will increase.
- e. Pressure and flow will remain the same.



Outcome 38: Recognizes the application characteristics of pneumatic components.

A typical pneumatic “bang bang” circuit consists of a cylinder that extends and retracts without an intermediate position, a four-way, two-position power valve (without an intermediate position), and an FRL unit that conditions plant air is piped to an air drop. A circuit of this type might be used to eject parts from a machine.

To condition plant air, the FRL unit removes the water and filters the air, reduces the pressure to a level that will move the load with the cylinder, and then meters lubricant as a mist into the air stream to lubricate the cylinder.

If the cylinder is located close to the air valve, the connecting tubing will be short. Air leaving the four-way power valve will enter the cap end of the cylinder on the extension stroke, and exit the power valve on the retraction stroke. That is, new air will enter the cylinder each time the cylinder completes a cycle. As the line length increases, the volume of compressed air in the line increases as well. As the cylinder cycles, the volume of air remaining on the low pressure side could become equal or exceed the amount of air required to extend and retract the cylinder. Under this condition, air in the line becomes stagnant and oil in the air stream may pool in the line rather than be transported in suspension to the cylinder. The significance of this condition is that while oil enters the air stream at the FRL unit, it may not actually reach the cylinder to provide lubrication.

There are a number of solutions to this problem. One possibility is to locate the FRL and power valve adjacent to the cylinder. This is not always possible. Reducing the size (diameter) of the air line will reduce the ratio of the line volume to the cylinder volume and increase the air velocity. Reducing the size of the airline also throttles the air supply to the cylinder. If the line is sufficiently long, there is no guarantee that lubricating oil in suspension will reach the cylinder. The solution that generally works best is to locate a quick exhaust valve at the cylinder so that air from the valve that powers the cylinder actually leaves the system on the return stroke. This will ensure that the oil mist released in the air stream will work its way, as a mist, through the line to the cylinder.

A quick exhaust valve is essentially a shuttle valve. In the circuit shown in Fig. 44, as the rod retracts, exhaust air from the cap end of the cylinder shifts the quick exhaust valve to release exhaust air to atmosphere at the cylinder rather than transporting it back through the tubing back to the power valve and then to atmosphere. In Fig. 44 this occurs only when the cylinder retracts.

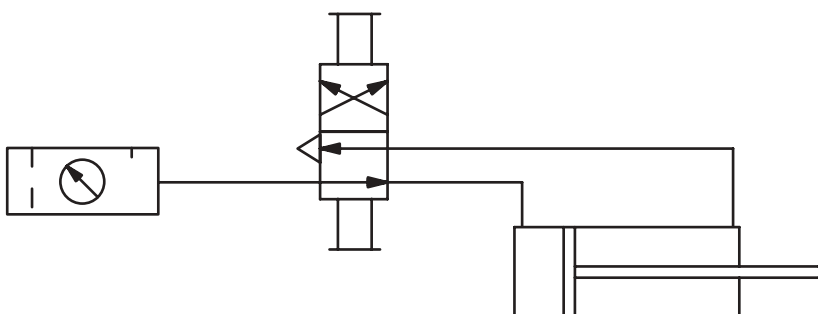

Fig. 43. Typical “bang-bang” air circuit.

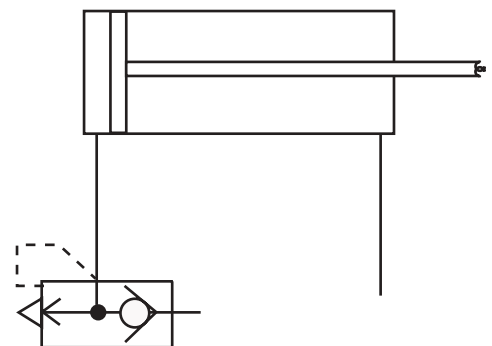

Fig. 44. Quick exhaust valve.

Review: 38.1.

Which one of the following will provide the best solution to a lack of lubrication, caused by long line runs, at an air cylinder?

- a. Increase line pressure.
- b. Locate a flow control at the cylinder port.
- c. Increase tubing diameter.
- d. Install a quick exhaust valve at the cylinder.
- e. Increase lubrication adjustment.



Outcome 39: Recognizes the operational characteristics of relieving and non-relieving pressure regulators.

Air regulators are pressure reducing valves. They keep the downstream pressure constant, regardless in fluctuations in either the upstream pressure or the rate of air consumption. This is only true, of course, if the upstream pressure is greater than the downstream pressure.

The two types of pressure regulators are relieving and non-relieving. Relieving regulators will vent off downstream gas if the downstream pressure rises above the pressure setting of the regulator. Relieving pressure regulators are not to be confused with pressure relief valves, which are safety valves used to protect the system from an over-pressure condition. For the most part, relieving pressure regulators are used in pneumatic systems to power actuators, air tools, spraying equipment, and blow-off nozzles. Non-relieving pressure regulators are used where the escape of gas or fluid is prohibited because it would create a hazard. For example, allowing flammable gasses such as propane fuel, oxygen (an oxidizer which supports combustion), and inert gasses such as nitrogen, would constitute a hazard.

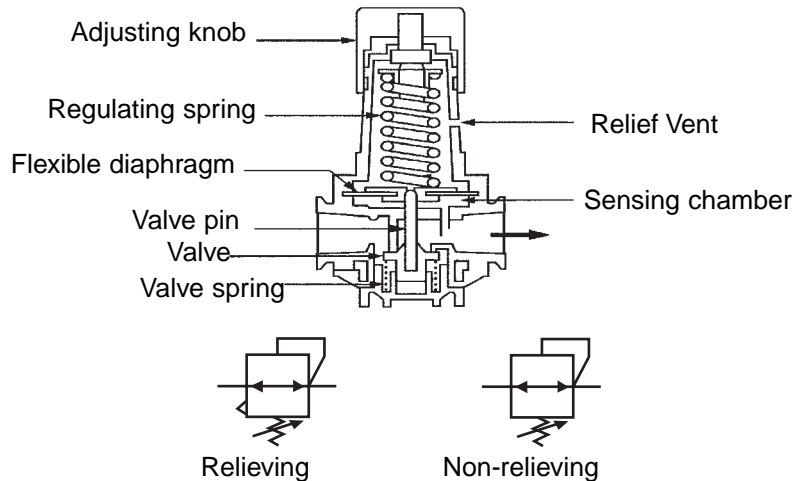

Fig. 45. Pressure regulator.

In the regulator shown in Figure 45, the adjusting knob controls the outlet pressure. Clockwise rotation of the knob increases the spring compression in the upper chamber, increasing the outlet pressure setting. Rotating the knob counterclockwise decreases the spring compression, decreasing the outlet pressure by decreasing the pre-load on the diaphragm. The diaphragm, which senses the downstream pressure, controls the outlet pressure. Downstream pressure acts on the bottom of the diaphragm which then acts upward on the main spring in the upper chamber. When the downstream pressure equals the setting controlled by the main spring in the upper chamber, the valve spring in the bottom chamber closes the valve. When the downstream pressure drops, the spring in the upper chamber opens the valve by applying a downward force on the valve pin. Thus, the pressure is balanced by downstream pressure acting against the pre-load set on the main spring by the adjustment knob.

A relieving pressure regulator regulates flow in order to maintain a given downstream pressure. Remember that pressure is caused by resistance to flow, generally caused by load resistance. Increased downstream pressure may also be caused by a force working back against the actuator, by an increase in the temperature of the downstream air, or by reducing the pressure setting of the regulator. As the pressure downstream of the regulator increases, flow through the regulator is modulated in order to maintain the set pressure. Pressure is sensed at the outlet port of the regulator. As the downstream pressure increases, the diaphragm is forced upward against the spring in the upper chamber, lifting it off the pin that rests under the orifice. This allows the downstream air to vent into the upper chamber of the regulator, and then through a small hole in the side of the regulator body and out to atmosphere. At this point, the flow of air from the upstream port of the regulator is closed. Regardless of the cause of the increased downstream pressure, the downstream pressure should never be greater than the pressure setting of the regulator. This is not the case with a non-relieving pressure regulator.

Air Compression and Preparation

Assume for a moment that a relieving regulator is connected to a 120 psig supply, and the regulator is set to 80 psig. If the setting is reset to 60 psig, the regulator will vent off enough downstream air to reduce the pressure in the circuit to 60 psig.

Non-relieving pressure regulators throttle the flow of toxic or flammable gasses, which would cause a hazard to personnel or property, were they to be vented to atmosphere. Even the venting of an inert gas, such as nitrogen, is a hazard if it is vented into an occupied area, because the nitrogen could displace oxygen to a level below that necessary to sustain life. As with relieving regulators, pressure is sensed on the downstream side of the regulator. If the pressure setting is reduced, or the downstream pressure increases for any reason, the over-pressure gas will not vent to atmosphere. No gas is lost from the circuit.

Review: 39.1.

Which one of the following gasses would use a relieving regulator for pressure control?

- a. Air.
- b. Propane.
- c. Oxygen.
- d. Argon.
- e. Nitrogen.

Air Compression and Preparation



Outcome 40:

Recognizes the operational characteristics of various types of vacuum generators.

Vacuum generators lower the pressure below atmospheric pressure. Typical applications that use vacuum include suction cups and vacuum packaging machines, material handling, and robotics. A number of scientific, chemical and biological processes are conducted in a vacuum in order to control conditions that affect product and process uniformity.

Atmospheric pressure at standard conditions exists when an inverted tube filled with mercury will support a column 29.92 inches high. This is one atmosphere and equivalent to 14.7 psia. The balance of pressure and vacuum are shown in Fig. 46, where atmospheric pressure is acting on the surface of the mercury and is balanced by a vacuum formed in the closed end of the tube, which also is the maximum theoretical vacuum that can be formed by a vacuum pump under standard conditions. Thus, if a column of mercury were raised by a vacuum pump, the theoretical maximum height would be 29.92 in-Hg.

Equating atmospheric pressure to the height of a column of mercury.

$$29.92 \text{ in-Hg} = 14.7 \text{ psia}$$

$$1 \text{ in-Hg} = 0.4913 \text{ psia}$$

$$1 \text{ psia} = 2.035 \text{ in-Hg}$$

Vacuum is measured by a negative gauge pressure (below atmospheric) measured by degrees:

Coarse vacuum = Up to 28 in-Hg

Fine vacuum = 28 in-Hg to 29.919 in-Hg

High vacuum = beyond 29.919 in-Hg, which is used in laboratories where it is measured in millimeters and microns.

For industrial purposes, a coarse vacuum is sufficient. Because the cost of generating a vacuum increases as the number of in-Hg increases, only the vacuum sufficient for the process is generated.

Mechanical vacuum pumps are similar in construction to air compressors, but with some differences. The vacuum is generated at the inlet rather than at the outlet and the pumping mechanism (pistons, diaphragms, rotary vanes, etc.) are under a negative rather than a positive pressure. Because not much air is pumped through the vacuum pump, the generated heat must be dissipated entirely by the housing, whereas in an air compressor, much of the heat of compression is transferred to the compressed air. A typical industrial mechanical vacuum pump will generate a vacuum of 24 in-Hg to 28.5 in-Hg, depending upon local atmospheric conditions.

Industrial venturi vacuum pumps operate from a compressed air source to create vacuums up to 28.5 in-Hg. They are small, reliable, and evacuate a high volume to create a vacuum in a short time. The vacuum is

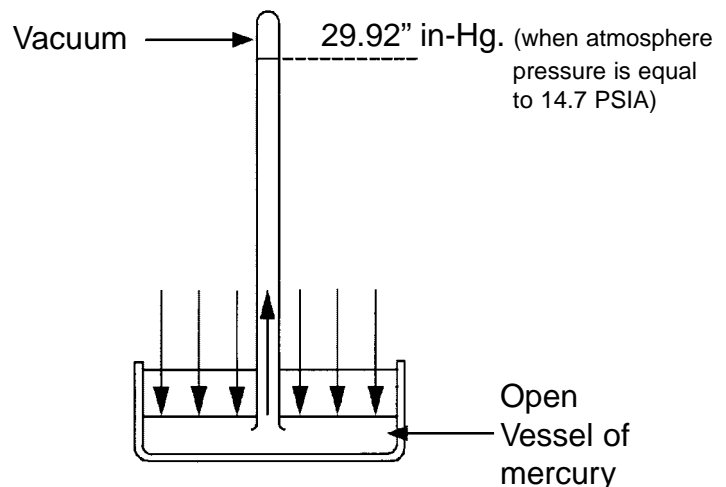

Fig. 46. Basic barometer measuring atmospheric pressure.

Air Compression and Preparation

created at the place where the venturi narrows the flow path through the generator. For example, an air supply at 80 psig will generate a vacuum of 28 in-Hg with an air consumption rate of 1 to 5 scfm, depending upon the vacuum flow rate. Thus, energy from the compressed air source is expended to create a vacuum in the region of the venturi at some flow rate less than compressed air flow. What happens is the velocity of the air stream increases through the venturi to supersonic speeds, causing the pressure to decrease. The vacuum is greatest near the narrowest part of the venturi. This is where the vacuum line is connected. Venturi vacuum pumps are equipped with a downstream air silencer to reduce noise, which can still exceed 70 db on the A-scale. The cross-section of a venturi vacuum pump is shown in Fig. 47.

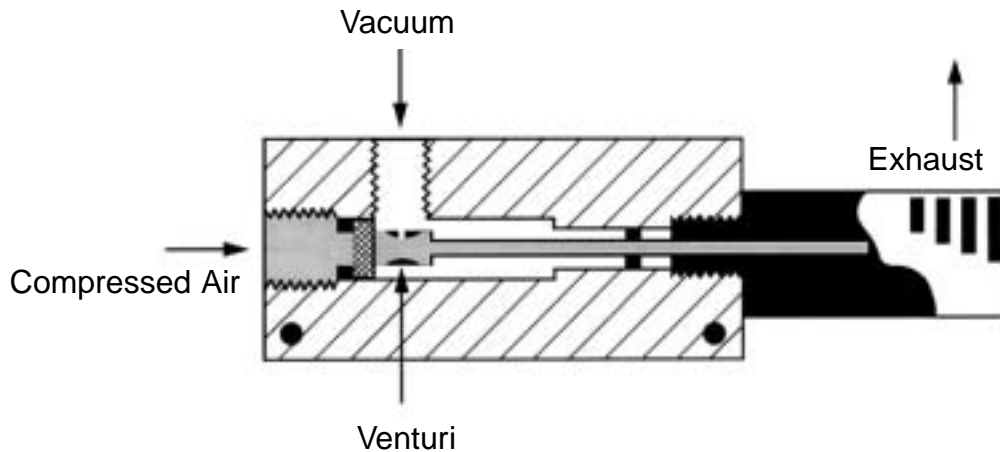

Fig. 47. Venturi vacuum pump principle.

Review: 40.1.

The noise from a venturi vacuum pump is controlled by the:

- Silencer
- Plumbing
- Inlet filter
- Venturi location
- Vacuum chamber

Control Components and Systems



Outcome 41: Computes the operational characteristics of a position feedback circuit.

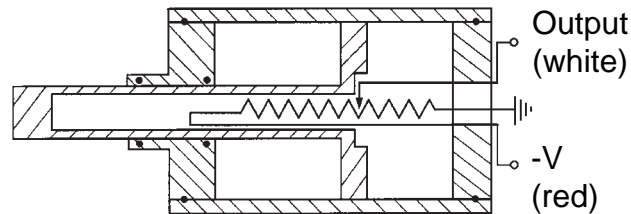

Fig. 48. Linear transducer circuit.

A pneumatic position feedback cylinder contains a linear transducer mounted in the cylinder head and a wiper assembly installed in the piston. A schematic of the circuit is shown in Fig. 48. As the piston moves, an electrical output signal is produced that is in proportion to the movement of the piston. For example, if a cylinder has a 12-inch stroke, and the output voltage is 0 volts D.C. when the rod is fully retracted, and -10 volts D.C. when the rod is fully extended, a voltage reading of -5 volts D. C. would indicate the cylinder was extended 6 inches to half the stroke.

When combined with a control circuit, the cylinder can be positioned with a repeatability of 0.001 in., if the components that are used have adequate resolution (see Outcome 49). A typical control circuit that integrates the control voltage input and feedback voltage determined by the position of the feedback cylinder is shown in Fig. 49. A control signal is sent to the electronic amplifier, which then calculates the difference between the control signal and feedback signal as the cylinder rod extends. The feedback signal giving the position of the cylinder is provided by the linear transducer. When the feedback voltage matches the control voltage, the cylinder will stop at the prescribed position.

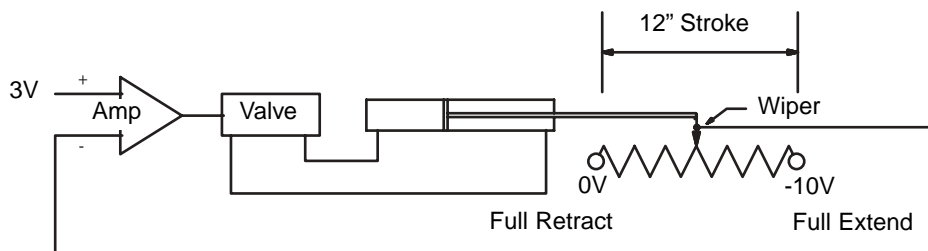

Fig. 49. Position feedback cylinder circuit.

The linear transducer shown has a full range voltage of 0 to -10 volts over a stroke of 12 inches. Thus, the linear transducer generates a change of $12 \text{ in.}/10 \text{ v} = 1.2 \text{ in./v}$. In this example, the negative voltage from the linear transducer increases as the cylinder rod extends and decreases as the cylinder rod retracts. The position of the cylinder rod extending when the control voltage is 3 volts is determined by multiplying the control voltage by the distance per volt traveled by the linear transducer ($12 \text{ in.}/-10 \text{ v} = -1.2 \text{ in./v}$). That is:

$$\text{Position extending} = 3 \text{ v} \times 1.2 \text{ in./v} = 3.6 \text{ in.}$$

Note that in the calculation shows above, the negative sign has been dropped from the distance per volt factor. What is important to remember is that the signal to the control valve is the summed difference between the

control and feedback voltages. Since the cylinder rod comes to rest when control and feedback voltages are equal, rod position is determined from the control voltage and in./v factor calculated for the linear transducer.

$$\text{Extension}_{\text{in}} = (\text{Cylinder Stroke}_{\text{in}} \times \text{Input Signal}_{\text{volts}}) / \text{Total LRT Range}_{\text{volts}} \quad E = (S \times \text{INP}) / \text{TR} \quad (\text{Eq. 28})$$

Review: 41.1.

If the circuit given in Fig. 49 had a cylinder stroke of 14 inches and the linear transducer had a range of 0 to -12 volts, what would be the approximate position of the cylinder rod when the control voltage shows 7 volts?

- a. 2.5" retracted.
- b. 6.8" extended
- c. 8.2" extended
- d. 9.4" extended
- e. 5.0" retracted



Outcome 42:

Uses Ohm's Law and Kirchoff's Law to solve series-parallel circuits for voltage, current and resistance.

Voltage, current and resistance values for series circuits are computed using Ohm's Law:

$$\text{Electromotive Force}_{\text{volts}} = \text{Current}_{\text{amps}} \times \text{Resistance}_{\text{Ohms}} \quad E = I \times R \quad (\text{Eq. 29})$$

Voltage, current and resistance values for parallel circuits are computed using Kirchoff's Law, which states that for resistors wired in parallel, the total resistance is the reciprocal of the combined resistance, which equals the sum of the reciprocals of each individual branch.

$$1/R_t = 1/R_1 + 1/R_2 + 1/R_3 + \dots (\text{Kirchoff's Law}) \quad (\text{Eq. 30})$$

Voltage, current and resistance values for series-parallel circuits are computed by first solving for the total resistance of the parallel branches and then combining it with the resistance in the series part of the circuit. Care must be exercised when evaluating series-parallel circuits because placement of the meter determines what the reading is measuring. In Fig. 50 for example, the meter is measuring the voltage drop across the series resistance.

Review: 42.1.

The voltmeter in the following circuit should read:

- 2 volts
- 3.2 volts
- 4 volts
- 6 volts
- 12 volts

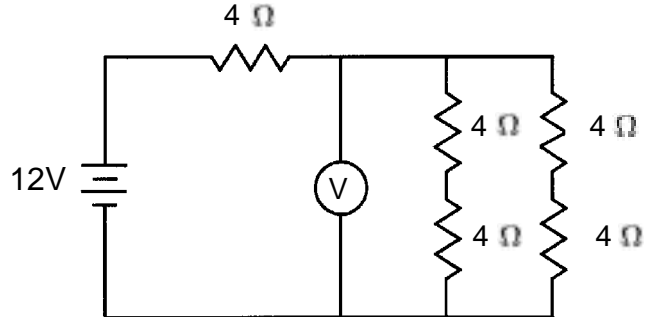

Fig. 50. Figure for Review 42.1
Voltage Drop Resistance Circuit



Outcome 43: Computes the voltage output signal from the operational characteristics of a strain gauge.

A strain gauge is a force transducer that produces a voltage that is proportional to the mechanical force applied to the gauge. Common examples of force transducers are piezoelectric crystals and strain gauges.

A strain gauge consists of a thin wire bonded to the surface of a diaphragm membrane or beam. In a pressure transducer, the force deflects the diaphragm which stretches the wire, increasing its length and reducing its cross-section, thereby increasing the electrical resistance of the wire. Even the slightest deformation of the membrane on which the strain gauge is bonded can be detected.

There are a number of electrical circuits that convert resistance changes in the strain gauge to a useful purpose. One common method is to use four gauges arranged in a bridge circuit that detects pressure (or force) changes in all four legs. The circuit receives a constant excitation voltage from a power supply, and then uses the amplified signal voltage to operate a pressure readout. This circuit is called a Wheatstone bridge.

For a transducer sensing pressure on a membrane, with all resistors having the same initial resistance, maximum voltage would be produced if resistors R1 and R2 were on one side of the membrane in compression, with resistors R3 and R4 on the other side in tension.

The signal voltage from the strain gauge is influenced not only by the resistance of the strain gauge, but by the constant excitation voltage from the power supply. For example, if the strain gauge has an output of 10 millivolts per volt of excitation at full scale, the output at half scale would be 5 millivolts per volt of excitation.

$$\text{Full Scale Excitation}_{\text{mv}} = \text{Output Voltage}_{\text{mv/volt}} \times \text{Excitation Voltage}_{\text{volts}} \quad \text{FSE} = \text{OV} \times \text{EV} \quad (\text{Eq. 31a})$$

$$\text{Indicated Pressure}_{\text{psig}} = (\text{Full Range Pressure}_{\text{psig}} \times \text{Output Signal}_{\text{mv}}) / \text{Full Scale Excitation}_{\text{mv}} \quad (\text{Eq. 31b})$$

$$\text{IP} = (\text{FRP} \times \text{OS}) / \text{FSE}$$

Review: 43.1.

A strain gauge pressure transducer with a maximum pressure range of 0 to 300 psig has an output of 5 millivolts per volt of excitation at full scale. The transducer is excited with a 6 volt DC power supply. The output (signal) voltage from the transducer at 100 psig is:

- a. 1 millivolt
- b. 5 millivolts
- c. 10 millivolts
- d. 25 millivolts
- e. 50 millivolts

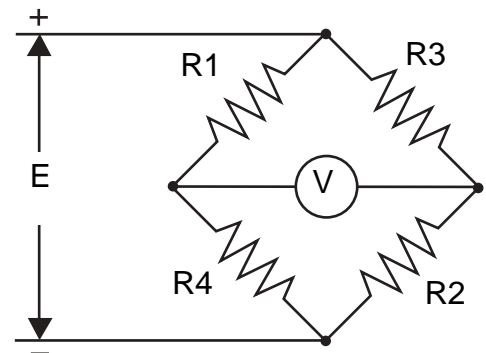

Fig. 51. Four resistor strain gauge bridge circuit.



Outcome 44: Identifies probable causes of pneumatic circuit failure from symptoms, sequence of circuit operations, circuit drawing and electrical schematic.

Troubleshooting a pneumatic circuit failure begins by tracing the malfunction to a faulty component. This can be done by identifying most likely faults from symptoms and operational characteristics of the machine. The same is true if the fault is electrical, except that the problem may be masked by a combination of pneumatic as well as electrical faults.

The circuit in Fig. 52 consists of two cylinders operated by solenoid actuated two-position, four-way valves. The ladder diagram electrical schematic for the circuit is shown at the bottom. By convention, the left side of the ladder has a plus voltage, while the right side of the ladder has a minus voltage or ground. The rungs of the ladder diagram are numbered down the left side so that wiring and electrical components in complex circuits can be traced.

In Fig. 52, rung 1 of the ladder logic diagram contains an emergency retract button labeled ER, a start switch labeled CS, a limit switch labeled 1LS (shown closed) that is tripped open by cylinder 1, and a control relay labeled 1CR coil. Rung 3 contains the contacts that are closed by 1CR that carry current to solenoid 1. Rung 4 shows the same control relay 1CR-1 connected to solenoid 1. Rung 3b also contains relay coil 2CR which is energized when 1LS is opened at the end of cylinder 1 extension stroke, closing 2CR-1 contacts and energizing solenoid 2. Rung 4b also contains relay coil 2CR which is energized when 1LS is opened at the end of cylinder 1 extension stroke, closing 2CR-1 contacts and energizing solenoid 2.

Here is how the circuit operates. When start CS button is pressed, control relay 1CR closes, actuating solenoid 1 in control valve 1 to extend cylinder rod 1. At full extension (position P2), cylinder rod 1 contacts limit switch 1LS which opens the circuit to 1CR, retracting cylinder rod 1, and closes control relay 2CR, actuating Solenoid 2 in control valve 2 to extend cylinder Rod 2. At full extension (position P4).

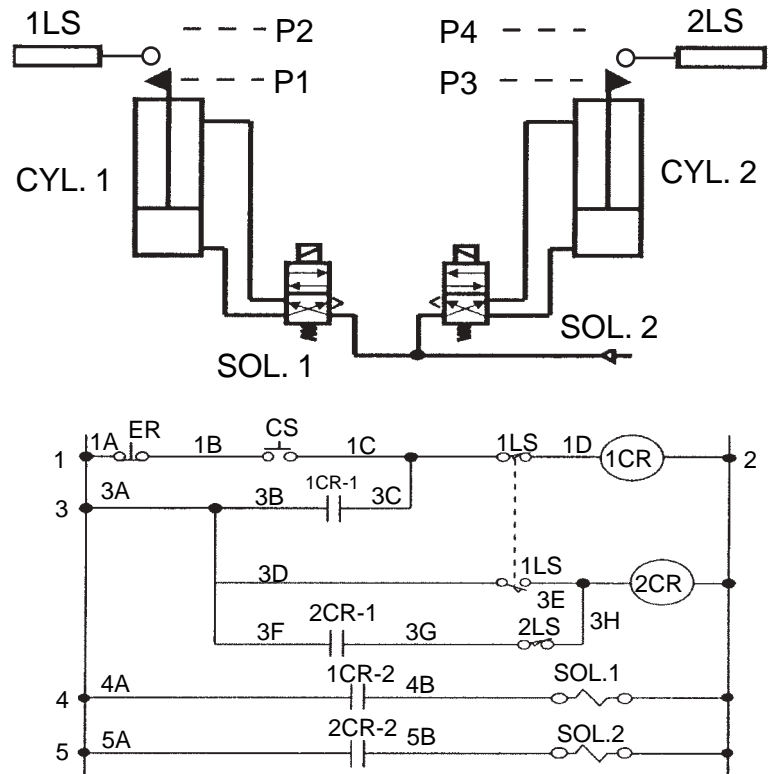

Fig. 52. Pneumatic circuit with electric controls.

Cylinder rod 2 contacts limit switch 2LS, opening the circuit to control solenoid 2 and cylinder rod 2 retracts. Both cylinders rods remain retracted until the start button restarts the cycle.

Review: 44.1.

What happens if the emergency retract button is pressed when cylinder 1 rod is fully extended?

- a. The circuit stops immediately.
- b. Cylinder 1 retracts, then the circuit stops.
- c. The circuit completes the normal cycle.
- d. Cylinder 1 stops, cylinder 2 extends, then the circuit stops.
- e. Cylinder 1 retracts, cylinder 2 extends, then the circuit stops.



Outcome 45: Applies Ohm's Law and Kirchhoff's Law to solenoid electrical circuits.

Pneumatic valves differ from their hydraulic counterparts in a number of ways. They are lighter, they operate at lower pressure, and shifting speeds and are usually higher.

Pneumatic valves are similar to their hydraulic counterparts in that solenoids are often used to shift the main valve spool or pilot valve spool, and problems associated with solenoids, such as burn out, are the same.

Pneumatic solenoid valves are available as DC units, particularly for mobile applications, and AC current units, which are appealing because of the availability of AC power in plants. Because DC solenoids do not have a high inrush current, solenoids should never fail due to low voltage or failure of the armature to seat. While recent advances have extended the service life of AC solenoids, traditionally, AC solenoids have failed because of the high inrush current, which is 2-5 times the holding current. If the solenoid does not completely seat, high current continues to be applied to the solenoid. Conversely, if the voltage is too low to shift the solenoid, the valve can still overheat because not enough force will be developed for the armature to completely shift. If the valve experiences high cycle rates, the high inrush current to shift the valve occurs more frequently and overheats the valve even more.

Calculating electrical values for the solenoid circuit and accessory equipment requires a knowledge Ohm's Law, Kirchhoff's Law, and the power formula, since ratings are given in watts:

$$\text{Power}_{\text{watts}} = E_{\text{volts}} \times I_{\text{amps}} = I_{\text{amps}}^2 \times R_{\text{Ohms}} \quad (\text{Eq. 32})$$

Review: 45.1.

A 24 volt DC solenoid rated at 6 watts is wired in parallel with two indicator lights that are wired in series with each other. One light is located at the solenoid, and the other light is located at an operator's station. If each indicator light consumes 0.25 watts, calculate the total resistance for the circuit.

- a. 76.7 ohms
- b. 88.6 ohms
- c. 98.4 ohms
- d. 108.5 ohms
- e. 125.6 ohms

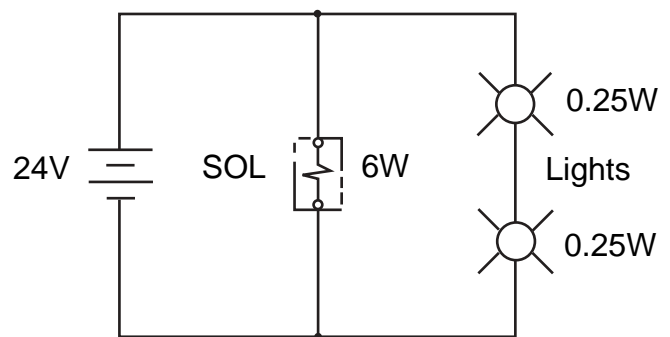

Fig. 53. Figure for Review 45.1
Resistance calculation circuit.



Outcome 46: Determines the cycle characteristics for a pulse width modulated (PWM) pressure control valve.

Pulse Width Modulated (PWM) electronic control has been used for pressure, flow, and directional control valves for some time. Examples include fuel management systems on automobiles that use a pulse width generator valve to vary fuel flow to injectors, which may receive 30% to 100% of full fuel flow based upon engine needs. The amount of fuel metered through the fuel injection system varies with the width of the pulse, the percentage of time the valve is open, and flow at full delivery. The wider the pulse, the longer the duration the valve remains open and the more fuel the injectors receive.

In pneumatics, this technology has been applied to pressure valves and directional control valves. The bar graph in Fig. 54 illustrates a signal which is shown ON during 6 milliseconds and OFF during 4 milliseconds, for a total duration of 10 milliseconds. As a percentage, the signal is ON 60% of the time and OFF 40% of the time.

For a pressure control valve, regulation of pressure begins at some minimum pulse width, for example 10%, and increases linearly to full pressure at some maximum pulse width, for example 90%. Thus, pressure regulation occurs within the range of pulse widths between 10% and 90%, or for a change of 80%.

There are two methods to solve for the output. The first method uses a graph and formulas, and the second method uses a series of four formulas. Assume the input signal is 60%.

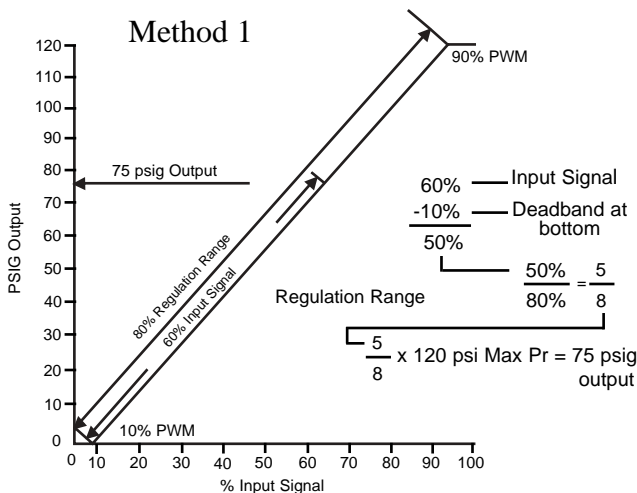

Method 2: (Equation 33)

$$OP = [MP \times (IS - PWCP)] / (PWFOP - PWCP)$$

Where:

- OP = Output pressure (psig)
- MP = Maximum Valve Pressure (psig)
- IS = Input Signal (%)
- PWCP = Pulse Width at Crack Pressure (%)
- PWFOP = Pulse Width at Full Output Pressure (%)

Given: Source at 120 psig, cracks at 10%, fully open at 90%, and a signal input of 60%:

$$OP = [120 \text{ psig} \times (60\% - 10\%) / (90\% - 10\%) = 75 \text{ psig}$$

Review: 46.1.

A pulse width modulated signal controls downstream air pressure from an upstream air source at 120 psig. If the signal begins to open the regulator at 20% ON and is wide open at 80% ON, what would be the pressure downstream of the valve when the input signal is at 60%?

- a. 20 psig
- b. 50 psig
- c. 60 psig
- d. 80 psig
- e. 84 psig

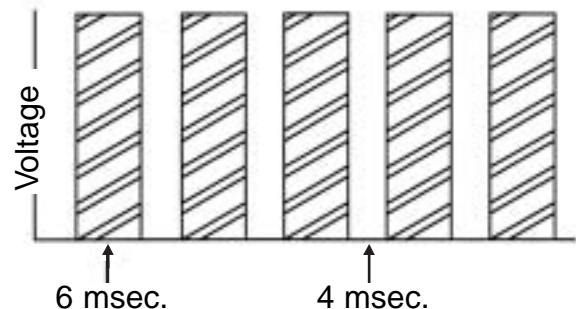

Fig. 54. Pulse Width Modulation (PMW) signal.



Outcome 47: Analyzes logic control circuits for an output signal.

Logic control circuits use air logic functions to manage the operation of the circuit. They are patterned after electrical relay logic and switching circuits which have been used for more than 50 years to control systems of all types.

Air logic systems have a number of advantages. They seldom self destruct from heat, electrical resistance or seizing, and their life expectancy is longer than their electrical counterparts. They are safe in explosive environments. Troubleshooting problems is easier, since faulty components can be isolated quickly by checking the tell-tale indicators that are built into the components.

Basic air logic functions include the AND, OR, NOT, MEMORY and TIME. Fig. 55 illustrates these functions with ANSI fluid power symbols.

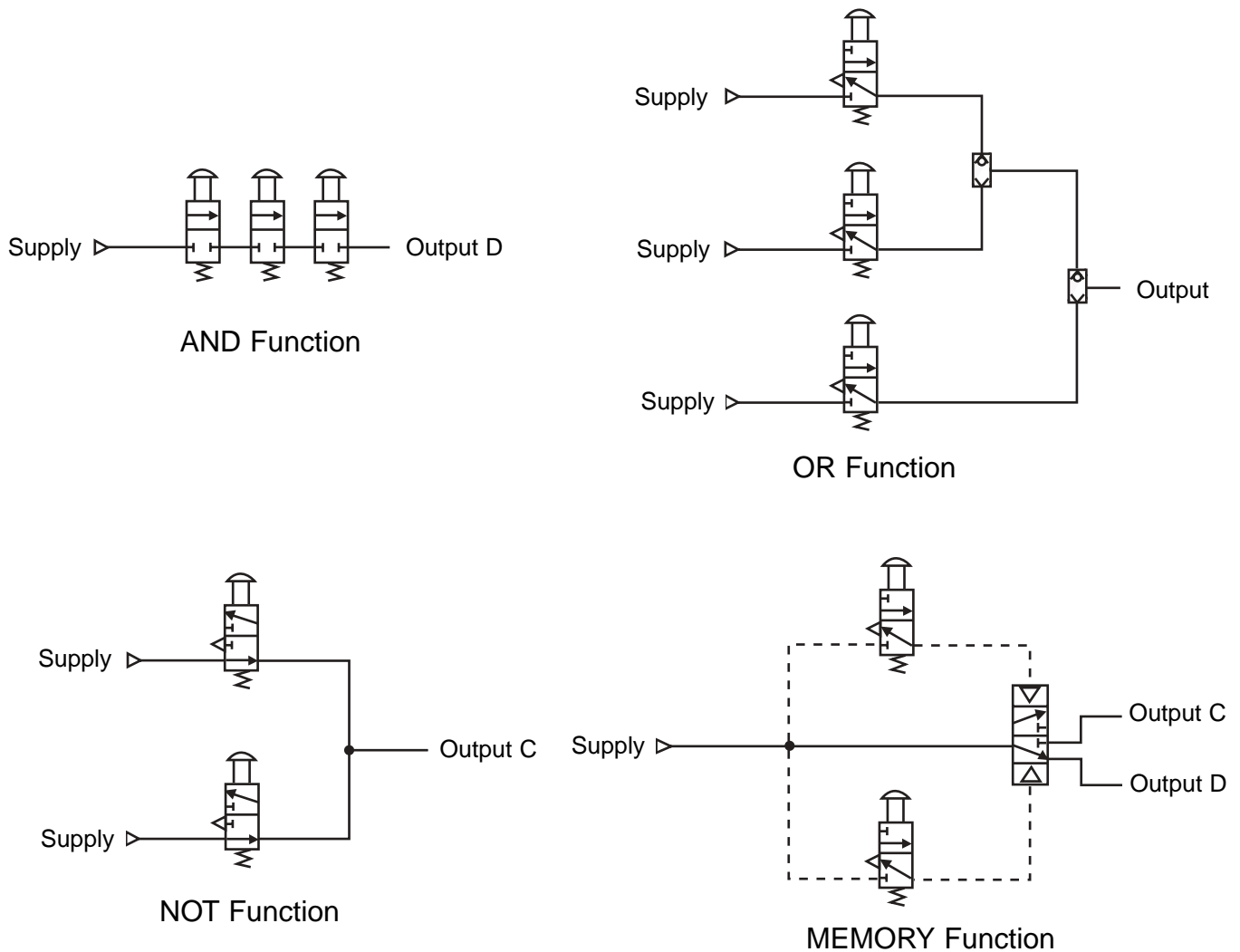

Fig. 55. Basic logic functions.

Control Components and Systems

In an AND function, two or more input signals must be present to obtain an output signal. Conversely, the output signal is off when so much as one input signal is off. In Fig. 55 this requires that valves A, B, and C must be actuated to result in an output at D. Notice that components in an AND circuit are connected in series.

An OR function will deliver an output signal at D if so much as one input from A, B, or C, is present. Notice that in an OR circuit valves A, B, and C are connected in parallel. In Fig. 55 these are shown as two-way valves in the normally off position.

In a NOT circuit, the output is on when the input is off. Fig. 55 illustrates the NOT function with two normally passing, two position, three-way valves connected in parallel. A signal is received at the output when both valves A and B are not actuated, and absent when valves A and B are actuated. If either valve A or B is depressed, the output at C is lost.

MEMORY is the ability for a circuit to retain a bias. The simplest circuit to retain a bias is one that uses two pilot valves to shift a two-position control valve when the directional control valve in Fig. 55 is shifted by a momentary signal from one of the pilot valves A or B. If both pilot valves are shifted simultaneously, nothing will occur since the pilot signal is balanced at both sides of the directional valve. Notice that the circuit has unlimited memory. That is, it will retain the position indefinitely until it is shifted back by the other valve. If limited memory is desired, for example in a one-shot circuit, some method must be used to introduce TIME as a function in the circuit.

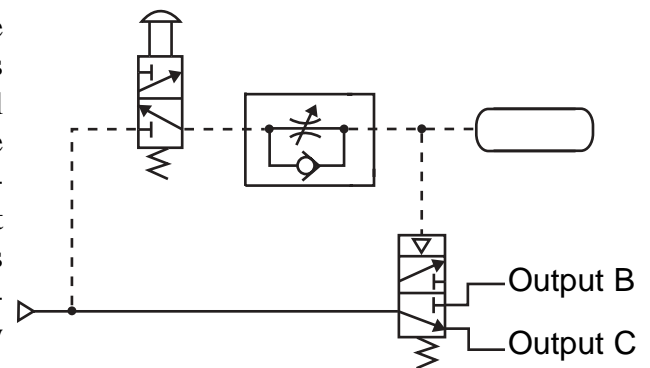

Fig. 56. Timing-in circuit.

Typically, TIME functions are introduced to delay or extend operations by placing a resistance and capacitance in a circuit. In the timing-in circuit shown in Fig. 56, the resistance is placed between the hand actuated pilot valve and the pilot on the directional control valve. Depressing pilot valve A will send a signal through the restrictor and into the capacitor. The time required to fill the capacitor and build pressure in the circuit is controlled by a variable orifice. The smaller the orifice, the longer the delay before the directional control valve will shift to switch the output from C to B.

In constructing and analyzing logic circuits, it is common practice to write statements that describe conditions that will provide either an output or no output, depending upon the purpose of the circuit. Various circuit functions may require that a number of conditions exist before the output is present or absent. Working forward from input signals, each leg of the circuit is analyzed until statements can be written that describe conditions at the output as they exist during various stages of the work cycle. For example, “an output is present at C when both A and B are actuated.”

Review: 47.1.

Which statement describes conditions that will provide an output?

- NOT A, OR B, AND C
- A, AND NOT B, OR C
- NOT A, AND B, AND C
- A, AND NOT B, AND C
- NOT A, AND NOT B, AND C

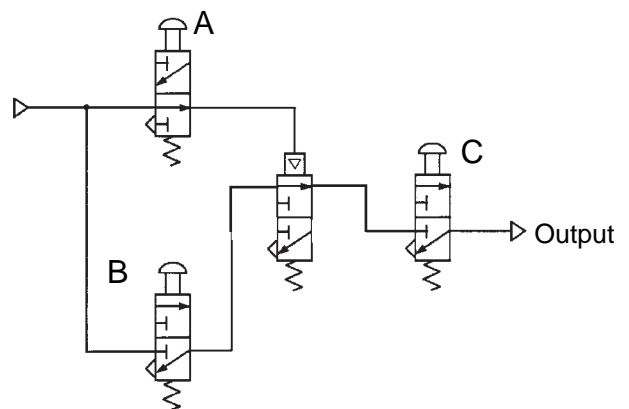

Fig. 57. Logic circuit.



Outcome 48: Computes the current output from a pressure transducer signal and transducer characteristics (also see Outcome 43).

When strain gauges are used to convert an air signal to an electrical signal, the input range is given by the air pressure signal, for example 0 to 200 psig, and the output is given in millivolts per volt of excitation at full scale. Again (from Outcome 43), if the strain gauge has an output of 10 millivolts per volt of excitation at a full scale reading of 200 psig, and the pressure in the system was at 100 psig, then the output voltage would be 5 millivolts. This 5 millivolt signal may be output to a digital display that is scaled to read out 100 psig. The signal may also be sent to a PLC, motion controller, or a feedback card for further use.

Some pressure transducers produce an output in milliamps rather than in millivolts, for example, 4 to 20 millivolts. Thus, at a system pressure of 0 psig, the transducer produces an output of 4 millivolts. This allows the control system to confirm that even though there is no system pressure, there are no broken wires as a input current is being received even when the system pressure is at zero psig. In addition, current loops are not subject to problems common to voltage loops, such as voltage drop, electromagnetic interference, etc.

As in a voltage output pressure transducer, the signal ratio from a current output transducer is proportional to the input pressure range of the pneumatic system and the output range of the pressure transducer. In the case of a current output transducer, this may be expressed by the following equation:

$$\text{Signal Ratio}_{\text{ma/psig}} = \text{TD Signal Range}_{\text{milliamps}} / \text{Max. TD Pressure Range}_{\text{psig}}$$

Note that the signal range begins when the transducer begins to provide an output higher than its minimum output. In the case of a 4 to 20 millivolt transducer, the range is 16 millivolts. Note that 0 to 20 millivolt transducers are also available; their output range is 20 millivolts and at zero system pressure no output signal is produced.

The output signal of the transducer is then a product of the signal ratio and the pressure in the system, added to the output signal of the transducer at zero pressure:

$$\text{Output Signal}_{\text{ma}} = (\text{Signal Ratio}_{\text{ma/psig}} \times \text{System Pressure}_{\text{psig}}) + \text{TD Signal}_{\text{mv}} @ 0 \text{ psig}$$

These formulas may be simplified to provide the following equation: (Eq. 34)

$$\text{Output Signal}_{\text{mv}} =$$

$$[(\text{System Pressure}_{\text{psig}} / \text{Maximum Pressure}_{\text{psig}}) \times (\text{Max Signal}_{\text{mv}} - \text{Min Signal}_{\text{mv}})] + \text{TD Signal}_{\text{mv}} @ 0 \text{ psig}$$

$$\text{OS} = [(\text{SP} / \text{MP}) \times (\text{MaxS} - \text{MinS})] + \text{S} @ 0 \text{ psig}$$

Thus, if the transducer discussed above had a 4 to 20 millivolt output, then:

$$\text{OS} = [(100 \text{ psig} / 200 \text{ psig}) / (20 \text{ mv} - 4 \text{ mv})] + 4 \text{ mv} = 12 \text{ mv output at 100 psig system pressure.}$$

Review: 48.1.

A 0 to 150 psig pressure transducer which produces a 4 to 20 milliamp signal is connected to a matching digital display. If the display shows 90 psig, what is the current from the transducer?

- a. 9.6 milliamps
- b. 12.0 milliamps
- c. 13.6 milliamps
- d. 16.0 milliamps
- e. 17.5 milliamps



Outcome 49: Computes the resolution for digital linear transducers from the signal input characteristics.

Four terms receive common usage in describing transducers:

1. Resolution - The ability of the transducer to resolve an output signal into units on the scale of the output device. High resolution means that a finer scale is used, which means the amplitude of full scale is divided into smaller increments.
2. Sensitivity - For commercial transducers, this is usually given in millivolts of output per volt of supply voltage at full-scale.
3. Accuracy - A percentage of full scale output. Common accuracy numbers given are 0.5% (one half of one percent), 1.0% and 3% of full scale.
4. Repeatability - The percentage of full scale within which the same value measured will be displayed at the output. Common repeatability numbers given are 0.5% (one half of one percent), 1.0% and 3% of full scale.

If voltage from AC (analog) output transducer is converted to a DC (binary) output displayed on an eight-bit binary readout device, the resolution can be no smaller than 1 part in 256 parts. If the full scale voltage from the transducer is 0 to 5 volts:

$$\text{LVDT Resolution}_{\text{mv}} = \text{Full Scale Voltage}_{\text{volts}} / 2^{\text{bits}} \qquad R_{\text{mv}} = \text{FSV} / 2^{\text{bits}} \qquad (\text{Eq. 35.})$$

If resolution is to be measured in inches of cylinder stroke

$$\text{LVDT Resolution}_{\text{in}} = \text{Stroke}_{\text{in}} / 2^{\text{bits}} \qquad R_{\text{in}} = S / 2^{\text{bits}} \qquad (\text{Eq. 36.})$$

Notice that as cylinder stroke increases, resolution decreases. That is, if cylinder stroke doubles, resolution becomes half of the previous value.

Review: 49.1.

A 20 inch stroke cylinder is equipped with a digital linear transducer which has an 8 bit output. What is the resolution?

- a. 0.019 inches
- b. 0.039 inches
- c. 0.078 inches
- d. 0.156 inches
- e. 0.312 inches



Outcome 50:

Matches appropriate wiring arrangements between PLC's and directional control valves.

Programmable logic controllers (PLC's) have their design history in logic based sequencing, but current products accept and generate proportional signals either in analog or digital form and can perform calculations, comparisons, and even proportional, integral and derivative (PID) functions in the case of PID process controllers.

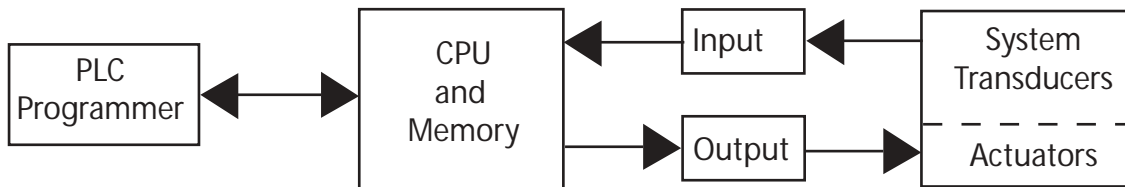

Fig. 58. Block diagram of PLC components.

A block diagram of components in a PLC are shown in Fig. 58. The programming unit can be a hand held unit or a terminal with a CRT and keyboard. A number of PLC's are programmed using ladder logic diagrams and logic commands (AND, OR, NOT, etc.) and diagrams that show on the CRT screen. BASIC is another common programming language. The central processing unit (CPU) contains the microprocessor that receives and stores data, performs program and math functions, monitors the status of input sensors, and controls output devices. The memory stores information the processor needs to make decisions as well as execute user instructions. Input data consists of electrical signals received from force, position, and pressure transducers (such as limit switches, pressure switches and force sensors) that are converted to 0 to 5v DC. Output signals convert low current DC to high output voltage (usually AC) current that is required to operate industrial equipment.

Input/output modules mounted next to the CPU provide the interface between the CPU and the controlled system. Input modules convert low voltage input signals from sensors to 5 v. D.C. for processing by the CPU. Output modules boost 5 v. DC signals from the CPU to high voltage and current levels required to power system actuators. Input/output devices generally require a power supply to drive input transducers and output actuators, some through output relays. Hard wired terminals are provided at the back of each module to connect electrical cables (normally two or four) between each input/output module and transducers and actuators.

One way to reduce the number of leads between input/output devices and sensors and actuators is to locate remote I/O modules near sensors and actuators, some distance from the central processing unit with their own power supply. Instead of running 32 to 256 leads in a cluster between CPU mounted input/output modules and sensor and actuators, one two-wire conductor connects through a multiplexer to a network of remote input/output modules. The multiplexer allows simultaneous communication using two or more signals on the same wire. For programmable logic controllers, multiplexing allows communication through a twisted pair of wires to a remote I/O device. A separate power source is required to operate the device.

Review: 50.1.

If the input/output modules for a programmable logic controller (PLC) are located near the actuator, how many wires are required between the PLC and the multiplexer for a remote valve manifold that has 12 double solenoid directional control valves?

- 1
- 2
- 9
- 16
- 25

References

- Anderson, Blaine W. (1967). The Analysis and Design of Pneumatic Systems. Malabar, Florida: Robert E. Krieger Publishing Company.
- Deppert, Werner and Stoll, Kurt. (1988). Cutting Costs with Pneumatics. Hauppauge, New York: Festo Didactic.
- Deppert, Werner and Stoll, Kurt. (1987). Pneumatic Control: an Introduction to Principles. Hauppauge, New York: Festo Didactic.
- _____. (1976). Vacuum and Pressure Systems. Carlstadt, New Jersey: Gast Manufacturing Corporation.
- Holbrook, Ed. L., and Chen, Pah, I. (1984). Design of Pneumatic and Fluidic Control Systems. Milwaukee, Oregon: Pech Publishing.
- Johnson, Jack L. (1992). Basic Electronics for Hydraulic Motion Control. Cleveland, OH: Hydraulics & Pneumatics Magazine.
- Johnson, James E. (1977). Electrohydraulic Servo Systems. Cleveland, OH: Hydraulics & Pneumatics Magazine.
- Lansky, Z. J. and Schrader, Lawrence F. (1986). Industrial Pneumatic Control. New York, New York: Marcel Dekker, Inc.
- Patrick, Dale R. and Patrick, Steven R. (1993). Pneumatic Instrumentation (3rd edition). Florence, Kentucky: Delmar Publishers, Inc.
- Pessen, David W. (1989). Industrial Automation: Circuit Design and Components. New York, New York: John Wiley and Sons.
- Rexford, Kenneth B. (1997). Electrical Controls for Machines (5th edition). Albany, NY: Delmar Publishers.
- Tonyan, Michael J. (1985). Electronically Controlled Proportional Valves. New York, New York: Marcel Dekker, Inc.
- Sullivan, James A. (1998). Fluid Power: Theory and Applications. Upper Saddle River, New Jersey: Prentice-Hall Publishing.
- Training Center. (1992). Closed Loop Electrohydraulic Systems Manual. Chapter 7. Closed loop system analysis. Rochester Hills, MI: Vickers Incorporated.
- Zejac, Ted (1997). Robotic Gripper Sizing. *Fluid Power Journal*, Vol 4. No. 6., P. 3. St. Joseph, MI: IPC Communications.

Solutions to Review Questions and Problems

1.1: e.

Solve Eq. 1 for the ratio of each of the sprocket pairs:

$$SR = OS / IS$$

$$40 / 8 = 5:1 \text{ and } 28 / 7 = 4:1$$

Then multiply the two ratios together to determine the final ratio:

$$(5:1) (4:1) = \underline{20:1}$$

The diameters of the sprockets are difficult to measure so the number of teeth on each sprocket were used.

1.2: d

First, convert the input torque to the conveyor from lb-ft to lb-in:

$$12 \text{ lb-ft} \times 12 \text{ inches per foot} = 144 \text{ lb-in}$$

Then solve Eq. 1 for the torque ratio 1:

$$144 \text{ lb-in} / 6 \text{ lb-in} = \underline{24:1}$$

1.3: d

Solve Eq. 5 for torque:

$$HP = (N \times T) / 5252$$

$$2.5 \text{ hp} = (2250 \text{ rpm} \times T) / 5252$$

$$T = \underline{5.84 \text{ lb-ft}}$$

1.4: e

First convert KW to hp by multiplying by 1.341:

$$4 \text{ KW} \times 1.341 = 5.35 \text{ hp}$$

Then solve Eq. 5 for torque:

$$HP = (N \times T) / 7124$$

$$5.35 \text{ hp} = (2400 \text{ rpm} \times T) / 7124$$

$$T = \underline{15.92 \text{ N-m}}$$

2.1: d

First solve Eq. 8 for the mechanical advantage:

$$MA = TRL / SRL$$

$$12'' / 3'' = 4:1$$

Then solve Eq. 9 for the reaction force on the rod bearing:

$$RF = MA \times SL$$

$$RF = 4 / 40 \text{ lbs} = \underline{160 \text{ lbs}}$$

3.1: a

First solve Eq. 10 for the horizontal friction force:

$$HFF = Cf \times L = 0.25 \times 1000 \text{ lbs} = 250 \text{ lbs}$$

Then solve for the area of the 3 inch bore cylinder:

$$A = 0.7854 \times D^2 = 0.7854 \times 3^2 = 7.07 \text{ sq-in}$$

Finally, solve for the pressure required to move the load (HFF):

$$P = F / A = 250 \text{ lbs} / 7.07 \text{ sq-in} =$$
$$p = \underline{35.36 \text{ psig}}$$

The closest answer greater than 35.36 psig is "a," 36 psig.

3.2: c

First use Eq. 11 to solve for the total incline force:

Pneumatic Specialist Certification Answer Manual

$$\text{TIF} = (\text{Cf} \times \text{L} \times \text{Cos } \theta) + (\text{Sin } \theta \times \text{L})$$

$$\text{TIF} = (0.35 \times 750 \text{ lbs} \times \text{Cos } 30^\circ) + (\text{Sin } 30^\circ \times 750 \text{ lbs})$$

$$\text{TIF} = (0.35 \times 750 \text{ lbs} \times 0.87) + (0.5 \times 750 \text{ lbs})$$

$$\text{TIF} = 228 \text{ lbs} + 375 \text{ lbs} = 603 \text{ lbs}$$

Note that since the load is being raised, the incline force is positive.

Then solve for the area of the 4 inch bore cylinder:

$$A = 0.7854 \times D^2 = 0.7854 \times 4^2 = 12.57 \text{ sq-in}$$

Finally, solve for the pressure required to move the load (TIF):

$$P = F / A = 603 \text{ lbs} / 12.57 \text{ sq-in} = \underline{48 \text{ psig}}$$

3.3: c

This problem is similar to 3.2 except that the incline force is negative.

$$\text{TIF} = (\text{Cf} \times \text{L} \times \text{Cos } \theta) - (\text{Sin } \theta \times \text{L})$$

$$\text{TIF} = (0.28 \times 2500 \text{ lbs} \times \text{Cos } 45^\circ) - (\text{Sin } 45^\circ \times 2500 \text{ lbs})$$

$$\text{TIF} = (0.28 \times 2500 \text{ lbs} \times 0.71) - (0.71 \times 2500 \text{ lbs})$$

$$\text{TIF} = 497 \text{ lbs} - 1775 \text{ lbs} = \underline{-1278 \text{ lbs}}$$

This indicates that the load will slide down the incline without the aid of the cylinder. In fact, the cylinder must be pressurized on the rod end in order to restrain (counterbalance) the load.

4.1: b

The force applied to the gripper fingers is the product of the force applied to the left side of the

scissors by the air cylinder times the mechanical advantage.

First solve for the force applied by the cylinder. Note that the cylinder applies the force as it is retracted.

$$F = \text{Annular Area} \times \text{Pressure}$$

$$F = (A1'' - A1/2'') \times 75 \text{ psig}$$

$$F = (0.7854 \text{ sq-in} - 0.20 \text{ sq-in}) \times 75 \text{ psig}$$

$$F = 0.59 \text{ sq-in} \times 75 \text{ psig} = 44.25 \text{ lbs}$$

Then solve Eq. 6 for the force on the part:

$$F1 \times L1 = F2 \times L2$$

$$44.25 \text{ lbs} \times 12'' = F2 \times 6''$$

$$F2 = \underline{88.5 \text{ lbs}}$$

5.1: a

The problem gives the maximum load as 100 Newtons. This is the maximum load the magnetic coupling would need to withstand. Newtons is the force unit in the SI Metric system of measure. Kilograms is the force unit in the traditional English system (cgs units). One way to make the conversion to Newtons would be to use the conversion factor of 1 Newton = 0.1022 kg. Another way to make the conversion would be to first convert Newtons to pounds using the conversion factor of 1 Newton = 0.2248 pounds, and then convert pounds to kilograms by using the conversion factor of 1 pound = 0.4536 kg:

$$1. 100 \text{ N} \times 0.1022 = \underline{10.2 \text{ kg}}$$

$$2a. 100 \text{ N} \times 0.2248 = 22.48 \text{ lbs}$$

$$2b. 22.48 \text{ lbs} \times 0.4536 = \underline{10.2 \text{ kg}}$$

6.1: c

From the example given in the Study Guide with

Figure 13, the downward acting vertical force developed by the boom at the point at which the cylinder rod is connected is 300 lbs. There are two ways to solve for the force into the cylinder rod.

By inspection of the 30-60-90 triangle discussed on page 16, we can use proportions and determine that if the vertical force is 300 pounds, and the vertical side is the same as side b, which is equal to a value of 1, then side c, which is the hypotenuse and is the component of the triangle that is equivalent to the cylinder, is equal to a value 2, then the load supported by the cylinder is equal to 600 pounds.

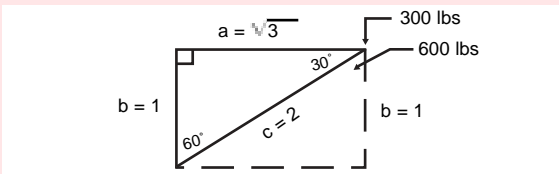

Solving the problem using trig functions, and based upon being given the angle and the value of the opposite side, we can use the sine function to solve for the value of the hypotenuse:

$$\sin \theta = \text{Opposite} / \text{Hypotenuse} = b/c$$

$$\sin 30^\circ = 0.5$$

$$0.5 = 300 \text{ lbs} / c$$

$$c = 600 \text{ lbs}$$

Next, knowing that the area of a 3 inch bore cylinder is 7.07 sq-in, solve for the pressure required to counterbalance the load:

$$P = F / A = 600 \text{ lbs} / 7.07 \text{ sq-in}$$

$$P = \underline{84.9 \text{ psig}}$$

7.1: d

A safety factor of 2 requires that each vacuum cup lift 120 lbs. Using a cup with a diameter of 4 inches, the pressure would balance 120 lbs is:

$$P = F / A = 120 \text{ lbs} / 12.57 \text{ sq-in} = 9.55 \text{ psig}$$

Solving Eq. 13:

$$\text{PSIG} = \text{PD} \times -0.4912$$

$$9.55 \text{ psig} = \text{PD} \times -0.4912$$

$$\text{PD} = \underline{19.44 \text{ in-Hg}}$$

7.2: d

Solve Eq. 13 for psig:

$$\text{PSIG} = \text{PD} \times -0.4913$$

$$\text{PSIG} = [0.001 \text{ mm-Hg} \times (1 \text{ in} / 25.4 \text{ mm})] \times -0.4913$$

$$\text{PSIG} = \underline{-0.000019343}$$

8.1: e

First convert 760 mm-Hg to in-Hg:

$$760 \text{ mm-Hg} / (1 \text{ in} / 25.4 \text{ mm/in}) = 29.92 \text{ in-Hg}$$

Then solve Eq. 14 for ft-H₂O:

$$\text{ft-H}_2\text{O} = \text{in-Hg} \times 1.133$$

$$\text{ft-H}_2\text{O} = 29.92 \text{ in-Hg} \times 1.133$$

$$\text{ft-H}_2\text{O} = \underline{33.9 \text{ ft-H}_2\text{O}}$$

9.1: d

Solve Eq. 5 for torque:

$$\text{HP} = (N \times T) / 5252$$

$$0.25 \text{ hp} = (1200 \text{ rpm} \times T) / 5252$$

$$T = 1.09 \text{ lb-ft}$$

Then convert the units from lb-ft to lb-in:

$$1.09 \text{ lb-ft} \times 12 \text{ lb-in/lb-ft} = \underline{13.13 \text{ lb-in}}$$

Finally, use the torque vs. speed graph located on the right side of Fig. 14. And find the intersection of 1200 rpm and 13.13 lb-in. The air pressure required is just under 60 psig

9.2: c.

Look at the torque vs speed graph on the right side in Fig. 14. Starting at the base line and tracing the line upward from 2000 RPM to the place where the line from the left margin at 17 lb-in. intersects, it appears that 80 PSI would be required to power the motor.

Now looking at the SCFM vs speed graph on the left side in Fig. 14, and tracing the line from the base line upward from 2000 RPM to the place where it intersects 80 PSI, and then tracing the line back to the left margin, it appears that air consumption will be approximately 20 SCFM.

10.1: e.

Reversing the check valve at the flow control orifice would allow free flow to both power valve pilots. But because the timing volume is in the right pilot line, it would take longer for pilot signal air pressure to build in the right pilot line. Air pressure on the left pilot would shift the power valve to start cylinder extension, but the right pilot signal would not be far behind and, together with the bias spring, would shift the power valve to retract the cylinder. How far the cylinder would extend cannot be determined from the circuit shown, but it appears likely there would be some movement of the cylinder because the pilot lines have different volumes, with the one on the right containing the timing volume.

11.1: a.

Notice when key lock valve 9 and start valve 1 in the circuit in Fig. 18 are in the normal (off) position that air is supplied from the FRL to the circuit from two sources:

1. Air is directed to power valves 6, 7, and 8.
2. Pilot air is directed to the right side of power valves 6, 7, and 8 through one side of the three shuttle valves.

Since all three signal output power valves are receiving air, the cylinder actuators will assume a position at one end of the stroke or the other. That is, the cylinders will either be extended or retracted.

Also notice that the pilot line directing air to the right side of power valves 6, 7, and 8 through the three shuttle valves will cause them to shift and retract cylinders 10, 11, and 12. Thus, all three cylinders will remain in the retracted position when key lock valve 9 and start valve 1 are in the normal (off) position.

11.2: a.

With key lock valve 9 in the actuated position, air is directed to three places:

1. Power valves 6, 7, and 8.
2. Signal processing limit valve 5.
3. Signal input start valve 1.

Since all three signal output power valves are receiving air, the cylinder actuators will operate. That is, the cylinders will either be extending, retracting, or remain extended or retracted.

The air signal through limit valve 5 is directed to the right pilot of power valve 8 through the shuttle valve causing it to retract, no matter what previous position it was in.

When signal input start valve 1 is depressed and held depressed, pilot air is directed to the left pilot of power valve 6, causing it to shift to the left envelope which extends cylinder 10. Notice that the right pilot of power valve 6 is vented back through key lock valve 9, and that return air from the rod side of cylinder 10 is exhausted to atmosphere through power valve 6.

When cylinder 10 reaches full extension it actuates limit valve 2, directing pilot air to the left side of power valve 7, shifting the valve to extend cylinder 11.

When cylinder 11 reaches full extension it actuates limit valve 3, directing pilot air to the left side of Power valve 8, shifting the valve to extend cylinder 12.

When cylinder 12 reaches full extension it actuates limit valve 4, directing pilot air to the right side of power valve 7 and power valve 6. However, since start valve 1 is held depressed, the unbiased power valve 6 cannot shift to retract cylinder 10. Since cylinder 10 cannot retract, limit valve 2 will not vent the left side of power valve 7 to allow it to shift and retract cylinder 11. Thus, if start valve 1 is held depressed, cylinders 10, 11, and 12 will extend and remain extended.

12.1: e.

Component failures are easiest identified with the function they perform. limit valve 2 is a signal processing component, so it is known that it controls the power valve through a pilot circuit. In this case, limit valve 2 is actuated by cylinder 10 at the end of the extension stroke, in order to send a pilot signal to shift power valve 7 to extend cylinder 11.

However, since key lock valve 9 is in the run position and limit valve 2 is stuck (actuated), the left side of unbiased (no spring return or centering) power valve 7 receives a continuous signal and cylinder 11 remains extended.

When cylinder 12 actuates limit valve 4, power valve 7 receives a signal to the right side through the top of the shuttle valve, but because there is an equal and opposing signal from limit valve 2 on the left side, power valve 7 cannot shift. Thus, cylinders 11 and 12 will not retract even though cylinder 10 does retract.

13.1: d.

The first valve to shift after start valve 1 is power valve 6, and this is the most likely answer of those given. If limit valve 2 were stuck (operated), cylinder 11 would be extended. If limit valve 4 were stuck, it would vent the right side of power valve 6 if the shuttle valve ball were stuck down. If the shuttle valve ball were stuck up, power valve 6 would still vent power valve 6 through key lock valve 9, so there is not a vent problem with power valve 6. If limit valve 5 were stuck it also would vent through lock valve 9.

14.1: c.

Connecting the air supply line in Fig. 18 that leads to power valves 6, 7, and 8 to the upper air line on the right side of key lock valve 9 would disable the system. Notice that the upper line also vents through key lock valve 9 when the valve is in the normal position.

The purpose for having the air line on the left side of key lock valve 9 is to provide an air supply to the power valves independent of pilot air which controls the circuit.

With key lock valve shifted, air would then be directed to power valves 6, 7, and 8, and to start valve 1. Depressing start valve 1 would cause the circuit to operate normally. However, returning key lock valve 9 to the normal position would vent the main air supply to power valves 6, 7, and 8, as well as the pilot circuit air. Thus, the entire function of the circuit would be lost.

15.1: b.

The circuit as shown meters-out air from the cylinder. When the four-way directional control valve is shifted to extend the cylinder rod, the 500 lb load will be restrained. However, meter-out control places a restriction on air flow leaving the cylinder. This will require a higher air pressure than that calculated from the magnitude of

the load to retract the cylinder rod because of back pressure on the blank end of the piston.

Remember that any restriction in either the inlet or outlet line to the cylinder will increase air pressure because of the pressure drop across the flow control orifice. This would be true whether the cylinder were loaded or not. Thus, the lowest pressure to lift the load would occur when both flow control valves A and B free-flow air with the cylinder retracting. This would require reversing the flow control check in valve A.

Notice that the load will still be restrained from falling. And since the load will cause the cylinder to extend under the force of gravity, no power loss is incurred by restricting metering-in air to the blank end of the cylinder as it extends.

16.1: d.

The components shown by the symbols include:

1. Check valve.
2. Pressure regulator (reducing valve).
3. Pilot operated two-way valve, normally non-passing.
4. Flow restrictor with reverse flow check valve.
5. Pilot operated three-way directional control valve, with the pressure port non-passing and return line vented.

The only component that would allow one cylinder to extend before the other is a flow restrictor with a return free-flow check valve. Component 3 would allow flow to the cylinder but not return flow. Also it would shift immediately, allowing both cylinders to retract together. Component 5 would allow flow in both directions, but there is no provision for the required delay.

17.1: d.

The deceleration signal comes near the end of the extension stroke. Three-way idle return

roller limit valve 6 provides a pilot signal to Component A, which must decelerate the rod while it is extending. This means that oil flow must be blocked at valve A and be routed through the flow control. Thus, valve 1 is used at A. However, when the rod retracts, flow must be unimpeded, so the pilot signal is vented back through normally vented idle return roller three-way limit valve 6 when the idle return roller comes into play.

18.1: c.

Table 1 is entered on the left side at 80 psi, and read across to an air flow greater than 11 scfm, and then upward to the appropriate pipe size. Where the column under 3/8 inch pipe intersects with the row across from 80 psi, a value of 23 scfm is given. This means that at a line pressure of 80 psi, a 3/8 inch pipe will deliver 23 scfm with a pressure drop of 10% in supply pressure for each 100 ft of pipe line. And since the line length is given as 100 ft long, the pressure drop would be less for a delivery of 11 scfm.

19.1: b

First solve Eq. 15 for volume:

$$T = [V \times (P_{\max} - P_{\min})] / (14.7 \times Q)$$
$$3 \text{ m} = [V \times (160 \text{ psig} - 140 \text{ psig})] / (14.7 \times 10 \text{ scfm})$$
$$V = 22.05 \text{ cu-ft}$$

Then convert cubic-feet to gallons:

To convert cubic-feet to gallons, multiply by 7.48

$$22.05 \text{ cu-ft} \times 7.48 = 164.93 \text{ gallons}$$

19.2: b

First convert 60 gallons to cubic-feet:

$$60 \text{ gal} / 7.48 = 8.02 \text{ cu-ft}$$

Note that the compressor is supplying 12 scfm of the 20 scfm demand. The receiver must then supply the other 8 scfm. Solve Eq. 15 for the

time the receiver can supply the 8 scfm:

$$T = [V \times (P_{\max} - P_{\min})] / (14.7 \times Q)$$

$$T = [8.02 \text{ cu-ft} \times (140 \text{ psig} - 100 \text{ psig})] / (14.7 \times 8 \text{ scfm})$$

$$T = \underline{2.73 \text{ minutes}}$$

20.1: d.

When Valve 2 is actuated and released, both power valves will be pilot operated to retract both cylinder #1 and cylinder #2, with the velocity controlled by meter out orifices in the power valves. Actuating valve 3 will pilot operate both power valves to extend both cylinder #1 and cylinder #2, with the velocity controlled by the meter out orifices in the power valves. If valve 3 is not released before valve 2 is actuated, theoretically the power valve pilots would not be vented and so the power valves will not shift. The same would be true if valve #2 were not released before valve 3 was actuated, the power valves would not shift. Therefore, both cylinder #1 and cylinder #2 would stay retracted. Actuating valve #2 extends both cylinders. Actuating valve #3 retracts both cylinders.

20.2: b.

The component least likely to affect the circuit in block 1 would be a pressure gauge because it does not affect the air flow or pressure. Components likely to have the most effect would be the pressure regulator or two-way valve, since they have the most control of pressure and flow. A slow-start valve would give an operator the most warning that the system was coming to pressure, particularly if components were in some intermediate position.

21.1: c.

The circuit is a two-hand interlock circuit, but not an anti-tie-down circuit because there are conditions when tying down one valve could endan-

ger the operator. For example, if valve 1 were tied down and valve 2 were depressed, the cylinder rod would extend but not retract because both ends of the cylinder rod are pressurized. Similarly, if valve 2 were tied down and valve 1 depressed, the cylinder rod would extend but not retract when valve 1 were released because both ends of the cylinder are vented. Thus, of the answers given, tying down V1 and depressing V2 would endanger the operator because the other hand could become entrapped in the machine when the cylinder rod extends.

21.2: d.

The circuit in Fig. 26 is a two-hand interlock that will not advance unless both palm buttons are depressed, and not retract unless both palm buttons are released. If only one palm button is depressed the pilot signal to shift the power valve to extend the cylinder is vented. If the cylinder rod is advancing (both palm buttons depressed) and one of the palm buttons is released, the pilot signal will be vented and the power valve will be spring returned to the center position, stopping the cylinder rod in mid-stroke. However, if the released palm button is then depressed, the cylinder rod will continue to advance to the end of the stroke and then stop.

22.1: b

The force required to move the load up the ramp with the air cylinder consists of the force required to move the load up the ramp plus the force required to compress the retraction spring.

First solve Eq. 11 for the force required to move the load up the ramp:

$$TIF = (C_f \times L \times \cos \theta) + (\sin \theta \times L)$$

$$TIF = (0 \times 75 \text{ lbs} \times \cos 30^\circ) + (\sin 30^\circ \times 75 \text{ lbs})$$

$$TIF = 0 + (0.5 \times 75 \text{ lbs}) = 37.5 \text{ lbs}$$

Then add the TIF to the value of the spring force to find the total force required by the cylinder:

$$TF = TIF + SF = 37.5 \text{ lbs} + 25 \text{ lbs} = 62.5 \text{ lbs}$$

Knowing that the piston area of a 2 inch bore diameter equals 3.14 sq-in, solve for the pressure required to counterbalance the load:

$$P = F / A = 62.5 \text{ lbs} / 3.14 \text{ sq-in}$$
$$P = \underline{19.90 \text{ psig}}$$

23.1: a.

Because the cylinder is single acting and returned by a gravity load, approximately half the air is required for the same cycle rate.

23.2: c.

Double-acting cylinders can exert equal force in both directions. If the cylinder is a single rod unit, extension and retraction pressures will have to be adjusted separately. If the unit has a double rod, the force will be the same because the areas are the same on both sides of the piston.

Neither single-acting nor double-acting cylinders are typically used for mid-stroke positioning, except in the case of double end rod cylinders with two pistons in two separate chambers, which change the length of the assembly by having each cylinder rod fully extended or retracted.

Both single-acting and double-acting cylinders have meter-in capability,

Double-acting cylinders use more air, and because there are more options for application, there is the potential for more rather than less problems.

24.1: e

First, knowing that the piston area of a 1.5 inch bore diameter cylinder equals 1.77 sq-in, solve

the single-acting cylinder version of E. 16:

$$CFM = (A \times S \times cpm) / 1728$$

$$CFM = (1.77 \text{ sq-in} \times 6 \text{ in} \times 60 \text{ cpm}) / 1728$$

$$CFM = 0.37 \text{ cfm}$$

Next, solve Eq. 17 for the compression ratio:

$$CR = (\text{psig} + 14.7) / 14.7$$

$$CR = (100 \text{ psig} + 14.7) / 14.7 = 7.80:1$$

Finally, solve Eq. 18 for scfm:

$$SCFM = CFM \times CR = 0.37 \text{ cfm} \times 7.80 \text{ cr} = \underline{2.88 \text{ scfm}}$$

24.2: e

First, we must convert the delivery of the compressor in free air (10 scfm at 0 psig) to cfm at 120 psig. Solve Eq. 17 for the compression ratio:

$$CR = (\text{psig} + 14.7) / 14.7$$

$$CR = (120 \text{ psig} + 14.7) / 14.7 = 9.16:1$$

Next solve Eq. 17 for cfm:

$$SCFM = CFM \times CR$$

$$10 \text{ scfm} = CFM \times 9.16$$

$$CFM = 1.09 \text{ cfm}$$

Then solve Eq. 16 for cycles per minute:

$$CFM = (A \times S \times cpm) / 1728$$

$$1.09 \text{ cfm} = (3.14 \text{ sq-in} \times 4 \text{ in} \times cpm) / 1728$$

$$cpm = \underline{150 \text{ cpm}}$$

25.1: b

First solve for the load on the pulley. Since there are two cables, the load on the pulley is 100 lbs.

Next, solve for the load on the end of the boom. The boom is a Third Class lever. The force-load relationship can be represented by applying Eq. 6 ($F_1 \times L_1 = F_2 \times L_2$) to the following diagram:

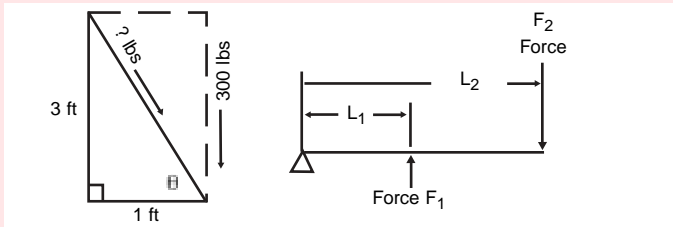

$$F_1 \times L_1 = F_2 \times L_2$$

$$F_1 \times 1 \text{ ft} = 100 \text{ lbs} \times 3 \text{ ft}$$

$$F_1 = 300 \text{ lbs}$$

Then calculate the length of the hypotenuse:

$$a^2 + b^2 = c^2$$

$$1^2 + 3^2 = c^2 = 1 + 9 = 10$$

$$c = 3.16$$

Since the length of the hypotenuse is 3.16 units, and side b is 3 units long, which is equivalent to the 300 lb load, the load along the hypotenuse is equal to 316 lbs.

Next, since the cylinder must support the load in retraction, calculate the annular area:

$$A_a = A_{\text{piston}} - A_{\text{rod}}$$

$$A = 3.14 \text{ sq-in} - 0.78 \text{ sq-in} = 2.36 \text{ sq-in}$$

Finally, solve for the pressure required to support the load with the annular area:

$$P = F / A = 316 \text{ lbs} / 2.36 \text{ sq-in} = \underline{133.9 \text{ psig}}$$

26.1: c

Using the process detailed in the Study Guide, first solve for the pressures required to extend and retract the cylinder:

$$P_{\text{ext}} = F_{\text{ext}} / A_{\text{ext}} = 400 \text{ lbs} / 7.07 \text{ sq-in}$$

$$P_{\text{ext}} = 56.6 \text{ psig extending}$$

$$P_{\text{ret}} = F_{\text{ret}} / A_{\text{ret}} = 600 \text{ lbs} / (7.07 \text{ sq-in} - 0.78 \text{ sq-in})$$

$$P_{\text{ret}} = 95.4 \text{ psig retracting}$$

Next solve Eq. 19 for the velocity in each direction:

$$V_{\text{ext}} = (S \times 5) / t = (24 \text{ in} \times 5) / 2 \text{ sec}$$

$$V_{\text{ext}} = 60.0 \text{ ft/min extending}$$

$$V_{\text{ret}} = (S \times 5) / t = (24 \text{ in} \times 5) / 3 \text{ sec}$$

$$V_{\text{ret}} = 40.0 \text{ ft/min retracting}$$

Then solve Eq. 20 for the cfm required in each direction:

$$\text{CFM} = (A \times V) / 144$$

$$\text{CFM}_{\text{ext}} = (7.07 \text{ sq-in} \times 60 \text{ ft/min}) / 144$$

$$\text{CFM}_{\text{ext}} = 2.95 \text{ cfm extending}$$

$$\text{CFM}_{\text{ret}} = (6.08 \text{ sq-in} \times 40.0 \text{ ft/min}) / 144$$

$$\text{CFM}_{\text{ret}} = 1.69 \text{ cfm retracting}$$

To solve Eq. 18 for the scfm required in each direction, one must first solve Eq. 17 for the compression ratio in each direction:

$$\text{CR} = (\text{psig} + 14.7) / 14.7$$

$$\text{CR}_{\text{ext}} = (56.6 \text{ psig} + 14.7) / 14.7$$

Pneumatic Specialist Certification Answer Manual

$$CR_{\text{ext}} = 4.85:1 \text{ extending}$$

$$CR_{\text{ret}} = (95.4 \text{ psig} + 14.7) / 14.7$$

$$CR_{\text{ret}} = 7.49:1 \text{ retracting}$$

Solving Eq. 18 in each direction:

$$\text{SCFM} = \text{CFM} \times \text{CR}$$

$$\text{SCFM}_{\text{ext}} = 2.95 \text{ cfm} \times 4.85 = \underline{14.29 \text{ scfm}} \\ \text{extending}$$

and,

$$\text{SCFM}_{\text{ret}} = 1.69 \text{ cfm} \times 7.49 = \underline{12.65 \text{ scfm}} \\ \text{retracting}$$

27.1: b

Solve Eq. 21 for the oil pressure:

$$P_{\text{Air}} \times A_{\text{Air}} = P_{\text{Oil}} \times A_{\text{Oil}}$$

$$140 \text{ psig} \times 12.57 \text{ sq-in} = P_{\text{Oil}} \times 0.20 \text{ sq-in}$$

$$P_{\text{Oil}} = \underline{8960 \text{ psig}}$$

27.2: b

First solve Eq. 21 for the air pressure:

$$P_{\text{Air}} \times A_{\text{Air}} = P_{\text{Oil}} \times A_{\text{Oil}}$$

$$P_{\text{Air}} \times 7.07 \text{ sq-in} = 4000 \text{ psig} \times 0.20 \text{ sq-in}$$

$$P_{\text{Air}} = 113.2 \text{ psig}$$

Next solve Eq. 22 for the number of strokes per minute required to provide the given flow rate:

$$Q = (A \times S \times \text{SPM}) / 231$$

$$0.25 \text{ gpm} = (0.20 \times 1.5 \text{ in} \times \text{SPM}) / 231$$

$$\text{SPM} = 192.5 \text{ strokes/min (cycles/min)}$$

Then solve the single-acting version of Eq. 16 for cfm:

$$\text{CFM} = (A \times S \times \text{cpm}) / 1728$$

$$\text{CFM} = (7.07 \text{ sq-in} \times 1.5 \text{ in} \times 192.5) / 1728$$

$$\text{CFM} = 1.18 \text{ cfm}$$

Next, solve Eq. 17 for the compression ratio:

$$\text{CR} = (\text{psig} + 14.7) / 14.7$$

$$\text{CR} = (113.2 \text{ psig} + 14.7) / 14.7 = 8.70:1$$

Finally, convert cfm to scfm by solving Eq. 18:

$$\text{SCFM} = \text{CFM} \times \text{CR} = 1.18 \text{ cfm} \times 8.7$$

$$\text{SCFM} = \underline{10.3 \text{ scfm}}$$

28.1: b

First, convert 150 lb-ft to lb-in:

$$150 \text{ lb-ft} \times 12 \text{ lb-in/lb-ft} = 1800 \text{ lb-in}$$

Then solve Eq. 23 for the area of the cylinders:

$$T = P \times A \times (PD/2) \times \#C$$

$$1800 \text{ lb-ft} = 100 \text{ psig} \times A \times (4 \text{ in} / 2) \times 2$$

cyl

$$A = 4.50 \text{ sq-in}$$

Finally, solve for the diameter of the cylinders:

$$A = D^2 \times 0.7854$$

$$4.50 \text{ sq-in} = D^2 \times 0.7854$$

$$D^2 = 5.73$$

$$D = \underline{2.39 \text{ inches}}$$

29.1: b.

First solve Eq. 25 for terminal velocity:

$$v_t = 2D/t$$

$$v_t = (2 \times 10 \text{ ft}) / 3 \text{ sec}$$

$$v_t = 6.67 \text{ ft/sec}$$

Then solve Eq. 24 for kinetic energy:

$$KE = (W \times v_t^2) / 64.4$$

$$KE = [40 \text{ lbs} \times (6.67 \text{ ft/sec})^2] / 64.4$$

$$KE = \underline{27.63 \text{ ft-lbs}}$$

30.1: d.

31.1: a.

32.1: c.

Solve Eq. 26 for C_v :

$$C_v = Q/22.67 \sqrt{T / [(P_{in} - P_{out})K]}$$

First convert the inlet and outlet pressures and the temperature to absolute values:

$$P_{in} = 80 \text{ psig} + 14.7 = 94.7 \text{ psia}$$

$$P_{out} = 72 \text{ psig} + 14.7 = 86.7 \text{ psia}$$

Next, determine the percentage of pressure drop:

$$(86.7 \text{ psia} / 94.7 \text{ psia}) \times 100 = 91.6\%$$

$$^{\circ}\text{Rankine} = ^{\circ}\text{Fahrenheit} + 460$$

$$^{\circ}\text{R} = 70^{\circ}\text{F} + 460 = 530^{\circ}\text{R}$$

Since the pressure drop is less than 10%, $K = P_{out}$

$$C_v = Q / 22.67 \sqrt{T / [(P_{in} - P_{out})K]}$$

$$C_v = 35 \text{ scfm} / 22.67 \sqrt{530^{\circ}\text{R} / [94.7 \text{ psia} - 86.7 \text{ psia}] 86.7}$$

$$C_v = \underline{1.35}$$

33.1: c.

Maximum flow rate through the orifice occurs at:

$$53\% \times p_1 = 0.53 \times 125 \text{ PSIG} = 66.25 \text{ PSIG}$$

By way of explanation, in Eq. 27, the value of the constant K depends upon the pressure drop across the valve. For a pressure drop of less than 10% (1% through 9%) of supply pressure, $K = p_2$. If the pressure drop is between 10% and 25% of supply pressure, $K =$ to the average of p_1 and p_2 -- that is $(p_1 + p_2)/2$. For pressure drops greater than 25% of supply pressure, $K = p_1$, but in no case can the pressure drop be greater than $0.53 p_1$ because at this point the critical velocity is reached and the formula is no longer valid. In practical applications this means that 0.53 times the upstream pressure is the limiting factor for passing air through an air valve to an actuator. Increasing the pressure above this value will result in a greater pressure drop across the valve, but will have little constructive effect on increasing production rates from cylinders and air motors receiving air from the valve.

34.1: e.

Solve Eq 26 for C_v :

$$C_v = Q/22.67 \sqrt{T / [(P_{in} - P_{out})K]}$$

First convert the inlet and outlet pressures and the temperature to absolute values:

$$P_{in} = 100 \text{ psig} + 14.7 = 114.7 \text{ psia}$$

Pneumatic Specialist Certification Answer Manual

$$P_{\text{out}} = 90 \text{ psig} + 14.7 = 104.7 \text{ psia}$$

$$^{\circ}\text{Rankine} = ^{\circ}\text{Fahrenheit} + 460$$

$$^{\circ}\text{R} = 90^{\circ}\text{F} + 460 = 550^{\circ}\text{R}$$

Next, determine the percentage of pressure drop.

$$(104.7 \text{ psia} / 114.7 \text{ psia}) \times 100 = 91.3\%$$

Since the pressure drop is less than 10% $K = P_{\text{out}}$

$$C_v = Q / 22.67 \sqrt{T / [(P_{\text{in}} - P_{\text{out}})K]}$$

$$C_v = 30 \text{ scfm} / 22.67 \sqrt{550^{\circ}\text{R} / [(114.7 \text{ psia} - 104.7 \text{ psia}) 104.7]}$$

$$C_v = \underline{0.959}$$

35.1: c.

First, solve Eq. 17 for the compression ratio:

$$\text{CR} = (\text{psig} + 14.7) / 14.7$$

$$\text{CR} = (100 \text{ psig} + 14.7) / 14.7 = 7.80:1$$

Then solve Eq. 27:

$$\text{ASD} = (\text{CD} \times \text{DC}) / (\text{CR} \times 100)$$

$$25 \text{ cfm} = (\text{CD} \times 60) / 7.8 \times 100$$

$$\text{CD} = \underline{325 \text{ scfm}}$$

36.1: b.

The aftercooler will remove approximately 85% of the water from the air due to heat of compression. Some water is also removed in the receiver as the air cools further, but most of the water is removed by the aftercooler. No water is removed by the inlet filter, first stage or intercooler.

37.1: d.

Since the pore size is larger, there will be less restriction through the filter, allowing the flow to increase. There will be no drop in downstream pressure, In fact, it might increase. Up stream pressure will remain the same.

38.1: d.

Installing quick-exhaust valves at the cylinder would be the best solution, but this is not one of the alternatives. Of those remaining, locating the lubricator closer to the cylinder is the most likely solution. Some of the other alternatives may actually aggravate the situation. Increasing pressure will not help, unless cycle rate were increase significantly. Increasing tubing diameter will increase tubing volume and make the situation worse. Injecting more oil into the air stream will likely make a mess and could damage the cylinder.

39.1: a

40.1: a.

The velocity of the air stream increases through the venturi to supersonic speeds, causing the pressure to decrease, but also generates substantial noise. An air silencer is attached downstream to reduce noise, which can still exceed 70 db on the A-scale. While having a silencer is critical, it must also be remembered that a minimum restriction to the action of the vacuum generator is required. Silencers are frequency tuned to cancel out as much noise as possible. A dense felt lining material is added to absorb additional noise as the air passes through the silencer.

41.1: c.

Solve Eq. 28 for extension:

$$E = (S \times \text{INP}) / \text{TR}$$

$$E = (14 \text{ in} \times 7 \text{ v}) / 12 \text{ v}$$

$$E = \underline{8.17 \text{ inches extended}}$$

Note that the value of the total range of the transducer ignores its polarity. If the input voltage was a negative voltage, the answer would be negative as well. The transducer would operate from 0 to +12 vdc, but the absolute value of the transducer range would still be used in the equation. The resulting answer would have to be subtracted from the total stroke of the cylinder.

42.1: d.

The circuit shown is a series-parallel circuit. The voltmeter will read only the voltage drop over the parallel portion of the circuit.

First analyze the resistance in the two parallel branches of the circuit. Resistors in series are additive, so basically, there are two 8 ohm resistors in parallel. Applying Kirchoff's Law (Eq. 30):

$$1 / R_t = 1 / R_1 + 1 / R_2$$

$$1 / R_t = 1 / 8 \text{ ohms} + 1 / 8 \text{ ohms}$$

$$1 / R_t = 2 / 8 \text{ ohms} = 1 / 4 \text{ ohms}$$

$$R_t = 4 \text{ ohms}$$

As the 4 ohm resistance of the parallel circuit is in series with the 4 ohm resistor, add the two resistances together to find the total resistance of the circuit:

$$4 \text{ ohms (individual resistor)} + 4 \text{ ohms (parallel circuit)} = 8 \text{ ohms}$$

Solve Eq. 29 to find the total amount of current flowing in the circuit:

$$E = I \times R$$

$$12 \text{ v} = I \times 8 \text{ ohms}$$

$$I = 1.5 \text{ amps}$$

Since the voltage drop across 8 ohms is 12 volts, the voltage drop across half the resistance is 6 volts:

$$E = I \times R$$

$$E = 1.5 \text{ amps} \times 4 \text{ ohms} = \underline{6 \text{ volts}}$$

43.1: c.

First solve Eq. 31a for FSE:

$$FSE = OV \times EV$$

$$FSE = 5 \text{ mv/v} \times 6 \text{ v} = 30 \text{ mv}$$

Solve Eq. 31b:

$$IP = (FRP \times OS) / FSE$$

$$100 \text{ psig} = (300 \text{ psig} \times OS) / 30 \text{ mv}$$

$$OS = \underline{10 \text{ mv}}$$

44.1: c.

Notice that leg 4 of the electrical circuit connects to the 2CR relay independent of the cycle start switch. When cylinder 1 is fully extended, the circuit to 1CR is opened and 2CR is closed. What happens is that cylinder 1 retracts while cylinder 2 extends. At the end of the stroke, cylinder 2 rod will open limit switch 2LS opening the circuit to 2CR and cylinder 2 will retract. Thus, the circuit will complete the normal cycle and then stop.

45.1: b

First, solve Eq. 32 for the current consumed by the indicator lights and the solenoid:

Lights:

$$P = E \times I$$

$$(0.25 \text{ watts} + 0.25 \text{ watts}) = 24 \text{ v} \times I$$

$$I = 0.02083 \text{ amps}$$

Solenoid:

$$P = E \times I$$

$$6 \text{ watts} = 24 \text{ v} \times I$$

$$I = 0.25 \text{ amps}$$

Next, solve Eq. 29 for the resistance of the lights and the solenoid:

Lights:

$$E = I \times R$$

$$24 \text{ v} = 0.02083 \text{ amps} \times R$$

$$R = 1152 \text{ ohms}$$

Solenoid:

$$E = I \times R$$

$$24 \text{ v} = 0.25 \times R$$

$$R = 96 \text{ ohms}$$

Finally, solve Kirchoff's Law (Eq. 30) for the total resistance of the circuit:

$$1/R_t = 1/R_1 + 1/R_1$$

$$1/R_t = 1/1152 + 1/96$$

$$1/R_t = (1152 + 96) / (1152 \times 96)$$

$$1/R_t = 1248 / 110,592 = 1 / 88.62$$

$$R_t = \underline{88.62 \text{ ohms}}$$

46.1: d

Method 1: Subtracting the deadband of 20% at the bottom from the input signal of 60% leaves a difference of 40%. Dividing this result by the regulation range of 60% and then multiplying by the maximum pressure ($\{40\% / 60\% \} \times 120 \text{ psig max. pr.} = 80 \text{ psig}$) gives the result of 80 psig from the regulator at a 60% input signal.

Method 2:

$$33a: \text{PWRR} = \text{PWFOP} / \text{PWCP}$$

$$\text{PWRR} = 80\% - 20\% = 60\%$$

$$33b: \text{PC} = (10\% \times \text{MP}) / \text{PWRR}$$

$$\text{PC} = (10\% \times 120 \text{ psig}) / 60\% = 20 \text{ psig}$$

$$33c: \text{NSI} = \text{IS} - \text{PWCP}$$

$$\text{NSI} = 60\% - 20\% = 40\%$$

$$33d: \text{OP} = (\text{PC} \times \text{NSI}) / 10\%$$

$$\text{OP} = (20 \text{ psig} \times 40\%) / 10\% = \underline{80 \text{ psig}}$$

47.1: c.

Notice that an output will occur when both C AND the directional control valve are actuated. To shift the directional control valve, valve A must be left in the unactuated position, that is, NOT A. Valve B, on the other hand, is non-passing in the normal position, so it must be actuated. Statements for valves A and B to actuate and power the directional control valve are

NOT A AND B

Thus, the complete statement to provide an output is:

Output when NOT Valve A AND Valve B, AND Valve C.

48.1: c

Solve Eq. 34 for signal signal:

$$OS = [(SP / MP) \times (MaxS - MinS)] + S @ 0 \text{ psig}$$

$$OS = [90 \text{ psig} / 150 \text{ psig}) \times (20 \text{ mv} - 4 \text{ mv})] + 4 \text{ mv}$$

$$OS = [(0.60 \times 16 \text{ mv})] + 4 \text{ mv}$$

$$OS = 9.6 \text{ mv} + 4 \text{ mv} = \underline{13.6 \text{ mv}}$$

49.1: c

An 8 bit output signal has 2^8 increments:

$$2^8 = 256$$

Solve Eq. 36 for the resolution in inches:

$$R_{in} = S / 2^{\text{bits}}$$

$$R = 20 \text{ inches} / 2^8$$

$$R = \underline{0.078125 \text{ inches}}$$

This means that the cylinder cannot be positioned accurately in increments smaller than 0.078 inches.

50.1: b

If the system has a serial relay module (multiplexer), only two wires are required. The valve bank must have its own power supply and logic circuit to communicate with the PLC. Serial relay modules are available to interface with a number of PLC brand models.



Introduction

Pre-tests are used to evaluate candidate preparedness for certification tests. Pre-tests may be either taken individually or in a group setting such as during a Review Training Session (RTS). As a part of an RTS, Pre-tests are used to allow the instructor to tailor the subject matter coverage to the needs of the audience. When a candidate is studying individually or in a small group, pre-tests provide insight into which areas require further study and whether the candidate should consider other study options, such as an RTS.

Included in this manual are three separate pre-tests for the Pneumatic Specialist certification test. Each pre-test has its own separate answer sheet which appears at the end of the pre-tests. Individual pre-tests are numbered PS-1, PS-2, and PS-3. The answer key for all three pre-tests appears at the end of the manual.

Candidates are encouraged to take a pre-test early in the study process. Pre-tests should be taken under timed conditions. A maximum of forty-five minutes should be allotted for each pre-test. This should be sufficient time to answer all sixteen questions on the pre-test. The results of the pre-test will guide the candidate to one of four possible courses of action regarding test preparation.

1. Take the test: Preparation is sufficient.
2. Study the material using the Study Manual.
3. Attend a Review Training Session (RTS): Preparation is good, but not sufficient to pass the test.
4. Participate in a formal (general) course: A Review Training Session would not provide adequate preparation to pass the test.

Additional pre-tests should be taken after individual study or attendance at an RTS to fur-

ther evaluate test readiness. In some instances, it may be desirable to take all three pre-tests at different times during the study process to better assess preparedness and effectiveness of study.

The answer sheets provided have been developed such that each question is referenced to a particular subject matter area of the study manual and of the test. The candidate is encouraged to fold the answer sheet vertically along the dotted line before taking the pre-test. This will eliminate any bias that may occur by having the appropriate outcome statement appear with the answers and more closely mimics actual test conditions. After checking the answers, the answer sheet may be opened to reveal the areas where further study is needed. This should enable directed study in the areas where a deficiency exists.

Candidates should be advised that each pre-test covers only a representative sample of the types of questions found on the test. Due to the need to keep the pre-test brief, not all subject matter is covered on every pre-test. Thorough preparation for the certification test is strongly encouraged.

The experience of taking pre-tests under timed conditions should reduce test anxiety associated with the actual certification test. If necessary, candidates may wish to retake the pre-tests after some period of time has elapsed to recheck their knowledge.

Suggestions or comments for improvements of these pre-tests and other certification materials should be sent to:

Fluid Power Society Education Institute
c/o FPS
3245 Freemansburg Avenue
Palmer, PA 18045
Phone: 610-923-0386, Fax: 610-923-0389
Web: www.ifps.org
E-Mail: askus@ifps.org

1. An air motor drives a shaft through a

Pneumatic Specialist Certification Pre-Test - 1

double reduction system using sprockets and chains. The air motor has a sprocket with 8 teeth driving an intermediate shaft with 40 teeth, the second sprocket on the intermediate shaft has 7 teeth connected to a final drive sprocket with 28 teeth. What is the final speed ratio between the air motor and final drive sprocket?

- 4 : 1
 - 5 : 1
 - 9 : 1
 - 15 : 1
 - 20 : 1
2. If a cylinder similar to the one shown has a 12 in. stroke and is extended 9 inches, what would be the reaction force on the rod bearing if the side load at the end of the rod were 40 lbs?

- 40 lbs.
- 80 lbs.
- 120 lbs.
- 160 lbs.
- 200 lbs.

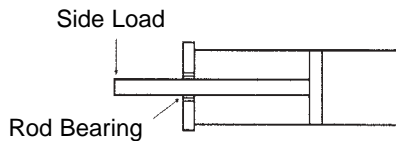

3. Estimate the gripper force in each finger if the air cylinder shown is supplied with 75 psig of air pressure.

- 30 lb
- 88 lb
- 118 lb
- 177 lb
- 236 lb

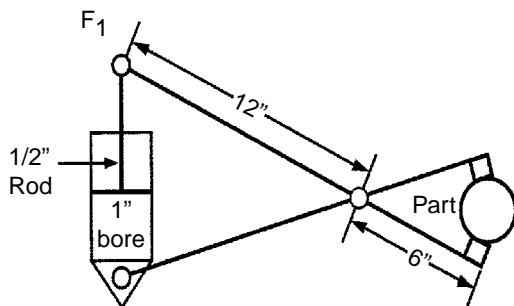

of 1 micron of mercury pressure drop?

- 0.000 000 812 psid
- 0.000 001 466 psid
- 0.000 003 959 psid
- 0.000 019 299 psid
- 0.000 038 722 psid

5. After reversing the check valve, which one of the following would likely occur if the palm operated valve in the circuit shown were operated and held depressed?

- Cylinder would lock up and after a time extend.
- After a time delay, the cylinder would extend.
- Cylinder would extend and stay extended.
- Cylinder would fully extend and after a time retract.
- Cylinder would partially extend and then retract.

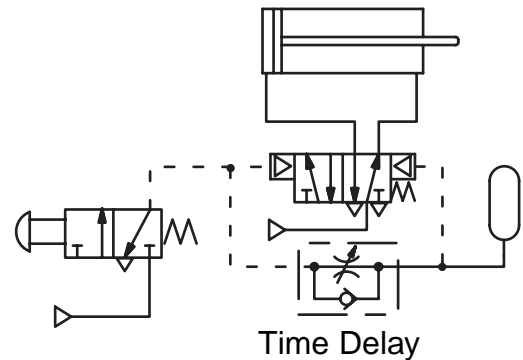

4. What is the psig gauge pressure equivalent 6. All three cylinders in the circuit shown are

Pneumatic Specialist Certification Pre-Test - 1

retracted. After key lock valve 9 has been set to the run position, start valve 1 is depressed and released but nothing happens. The air pressure gauge shows 100 psig. What component is most likely stuck?

- a. Limit valve 2
- b. Power Valve 8
- c. Limit valve 5
- d. Power valve 6
- e. Shuttle valve at power valve 6

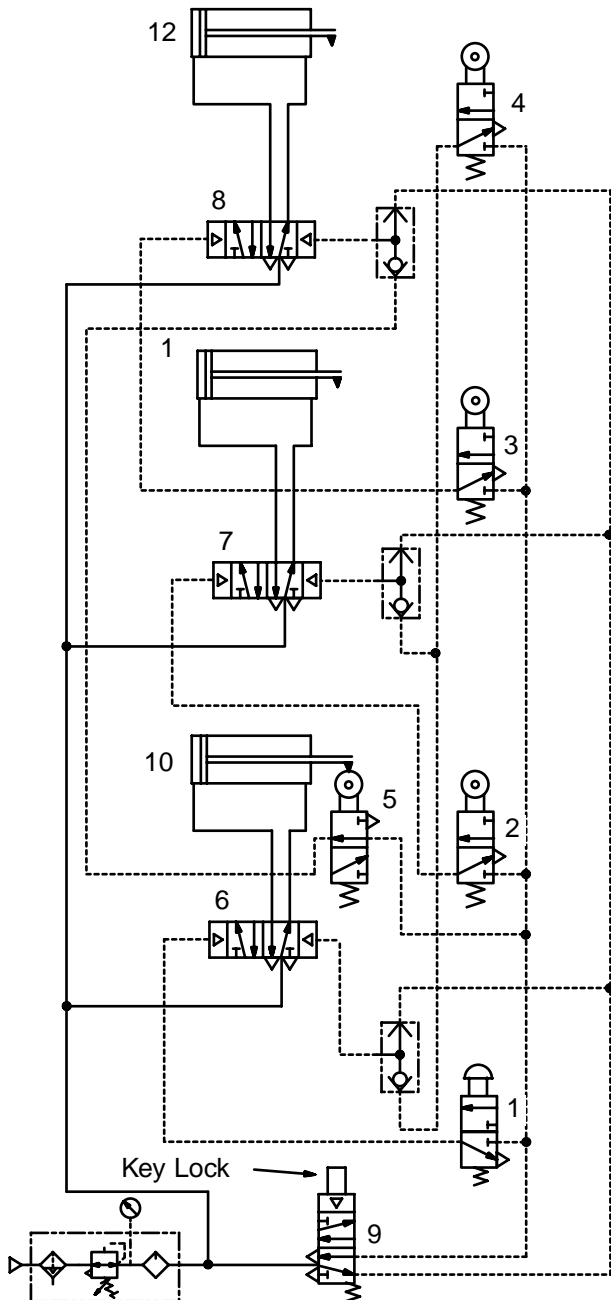

7. The circuit shown should extend one

cylinder followed by extending the other. Both cylinders should retract. Which component should be installed in position A to achieve proper operation?

- a. Component 1
- b. Component 2
- c. Component 3
- d. Component 4
- e. Component 5

Available Valves:

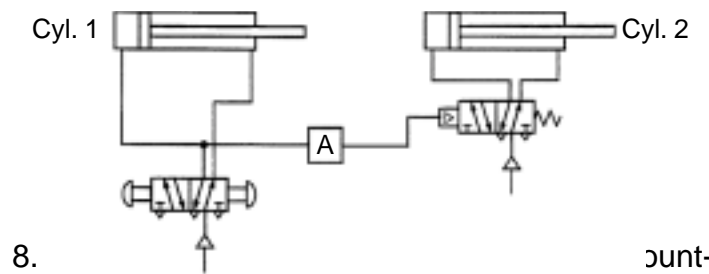
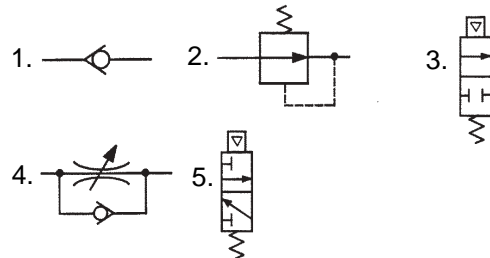

8. e. On a 60 gal receiver supplies 12 scfm d

on a 60 gal receiver supplies 12 scfm at 140 psig. If demand is 20 scfm, approximately how long will it be before the pressure drops to 100 psig?

- a. 1.55 min.
- b. 2.73 min.
- c. 5.60 min.
- d. 8.33 min.
- e. 15.78 min.

9. In the two-hand interlock circuit shown (see figure 26, page 43), if one of the palm buttons is released and then depressed again while the cylinder rod is in mid-stroke advancing, the cylinder rod will:

- a. stop and then retract.
- b. retract and then lock up.
- c. stop and remain stopped.
- d. stop and then continue to advance to the end of the stroke.
- e. continue to advance to the end of the stroke and then stop.

Pneumatic Specialist Certification Pre-Test - 1

10. How much air (scfm) is required to power a single-acting air cylinder having a 1.5 inch bore and 6 inch. stroke that cycles 60 times per minute on 100 psig? Neglect the retraction time.
- 0.25 scfm.
 - 0.37 scfm
 - 0.72 scfm
 - 1.44 scfm
 - 2.87 scfm
11. An air-oil intensifier with a 4 inch diameter bore and 2 inch stroke powers an oil piston intensifier with a 0.5 inch diameter bore. What would be the maximum oil pressure from air supplied at 140 psig?
- 1120 psig
 - 9000 psig
 - 9900 psig
 - 11,200 psig
 - 18,860 psig
12. Which cylinder design is most effective in supporting side loading?
- Guided rod mount
 - Nose mount.
 - Block mount.
 - Universal mount.
 - Clevis and pivot mount.
13. The average air consumption rate of a system is 25 cfm at 100 psig. Assume that the system includes an air receiver that adequately supplies air during times of peak air consumption. What size compressor, in scfm, is needed if the compressor is to operate at a 60% duty cycle?
- 69 scfm
 - 117 scfm
 - 325 scfm
 - 195 scfm
 - 42 scfm
14. Which one of the following gases would use a relieving air regulator to control the pressure?
- Air
 - Propane
 - Oxygen
 - Argon
 - Nitrogen
15. A strain gauge pressure transducer with a maximum pressure range of 0 to 300 psig has an output of 5 millivolts per volt of excitation at full scale. The transducer is excited with a 6 volt DC power supply. The output (signal) voltage from the transducer at 100 psig is:
- 1 millivolt
 - 5 millivolts
 - 10 millivolts
 - 25 millivolts
 - 50 millivolts
16. Which statement describes conditions that will provide an output?
- NOT A, OR B, AND C
 - A, AND NOT B, OR C
 - NOT A AND B, AND C
 - A, AND NOT B, AND C
 - NOT A, AND NOT B, AND C

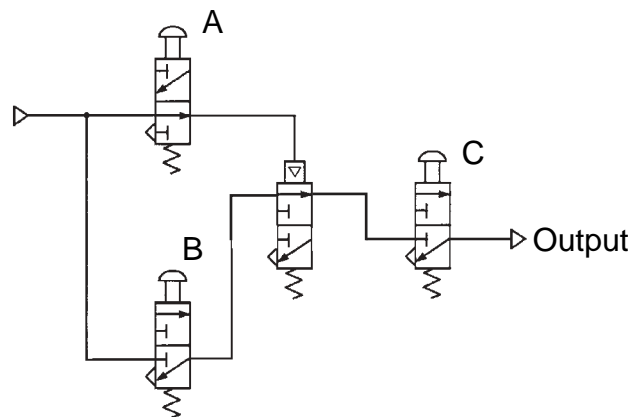

Pneumatic Specialist Pre-Test - 1 Answer Sheet

| Outcome: | Page | Answers |
|--|------|---------------|
| 1. Solves formulas for torque, speed and horsepower of an air motor connected through a reduction system to a conveyor. | 11 | 1. A B C D E |
| 2. Solves for the reaction force on a cylinder rod bearing from the stroke, mechanical advantage and side load on the rod. | 14 | 2. A B C D E |
| 4. Computes the cylinder bore diameter and pressure to operate a gripper through a mechanical advantage. | 19 | 3. A B C D E |
| System Analysis and Troubleshooting | | |
| 7. Solves for the pressure and suction area to provide a required lifting force using vacuum cups. | 22 | 4. A B C D E |
| 10. Predicts the operation of a pneumatic circuit from the placement of components in the circuit. | 26 | 5. A B C D E |
| 13. Identifies the most likely fault in a pneumatic circuit from symptoms and operational characteristics. | 32 | 6. A B C D E |
| System Design | | |
| 16. Selects the location of various components in a circuit to achieve cylinder sequence functions. | 36 | 7. A B C D E |
| 19. Uses formula to size air receivers to perform various functions. | 40 | 8. A B C D E |
| Component Application | | |
| 21. Identifies the most and least important safety considerations in the design of an air circuit. | 42 | 9. A B C D E |
| 24. Computes the cfm of air flow to power an air cylinder. | 47 | 10. A B C D E |
| 27. Calculates the oil flow rate and pressure from a pneumatic intensifier. | 52 | 11. A B C D E |
| 31. Associates cylinder designs with their applications. | 58 | 12. A B C D E |
| Air Compression and Preparation | | |
| 35. Calculates the required compressor delivery capacity from the system demand, pressure and duty cycle. | 64 | 13. A B C D E |
| 39. Recognizes the operational characteristics of relieving and non-relieving pressure regulators. | 72 | 14. A B C D E |
| Control Components and Systems | | |
| 43. Computes the voltage output signal from the operational characteristics of a strain gauge. | 79 | 15. A B C D E |
| 47. Analyzes logic control circuit for an output signal. | 84 | 16. A B C D E |

Pneumatic Specialist Certification Pre-Test - 2

1. A torque wrench registers 12 lb-ft. when a technician turns the input shaft on a conveyor like that shown. When the technician checks the torque on an available air motor by applying shop air, the reading on the torque wrench is 6 lb-in. Neglecting friction, what gearing ratio would be necessary to provide the necessary torque to turn the conveyor?

- a. 2 : 1
- b. 8 : 1
- c. 16 : 1
- d. 24 : 1
- e. 32 : 1

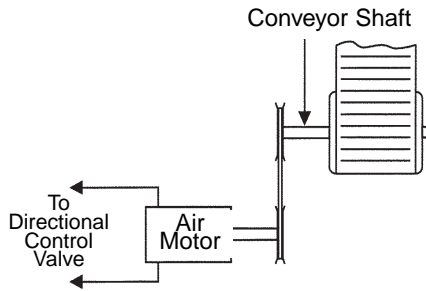

2. A 1000 lb load is pushed horizontally. If the coefficient of friction between the surface and the load is 0.25, and the cylinder shown has a 3 inch bore diameter, what minimum air pressure given would be required to move the load?

- a. 36 psig
- b. 52 psig
- c. 64 psig
- d. 100 psig
- e. 200 psig

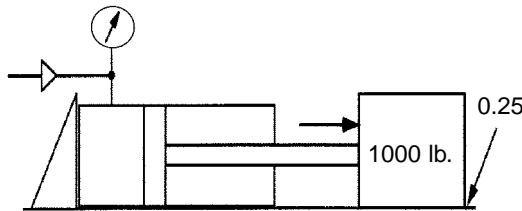

3. The magnetically coupled rodless cylinder shown is to be used to move the load vertically. The load and load support fixture have a combined weight of 100 newtons. Assuming slow speed operation and ignoring start-up acceleration, calculate the minimum magnetic retaining force required to move the fixture in kilograms.

- a. 10.2 kg
- b. 22.5 kg
- c. 45.5 kg
- d. 90.9 kg
- e. 202.0 kg

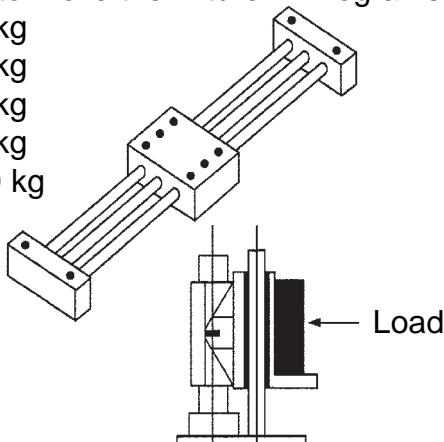

4. If a barometer will support a 760 mm column of mercury at standard atmospheric conditions, how many feet of water would this be? (Round the answer to three places)

- a. 6.042 ft
- b. 10.183 ft
- c. 23.950 ft
- d. 27.558 ft
- e. 33.899 ft

5. With key lock valve 9 and start valve 1 in the normal (off) position, what will be the final position of cylinders 10, 11, and 12?
See problem PT-2-6 for circuit.

- a. Cylinder 10 retracted, cylinder 11 retracted, cylinder 12 retracted.
- b. Cylinder 10 retracted, cylinder 11 retracted, cylinder 12 extended.
- c. Cylinder 10 retracted, cylinder 11 extended, cylinder 12 extended.
- d. Cylinder 10 extended, cylinder 11 extended, cylinder 12 extended.
- e. Cylinder 10 extended, cylinder 11 extended, cylinder 12 retracted.

Pneumatic Specialist Certification Pre-Test - 2

6. In the circuit shown, if the incoming air supply line that leads to power valves 6, 7, and 8 was disconnected and then reconnected to the upper right line of key lock valve 9, how would the operation of the circuit be affected?
- Power air would then pass through start valve 1.
 - Key lock valve 9 would act as an air relief valve.
 - Key lock valve 9 in the normal position, supply air is not vented.
 - After the key lock valve is actuated, depressing start valve 1 would operate the circuit normally.
 - All cylinders would remain in the reaction position.

Used for problems 5 & 6

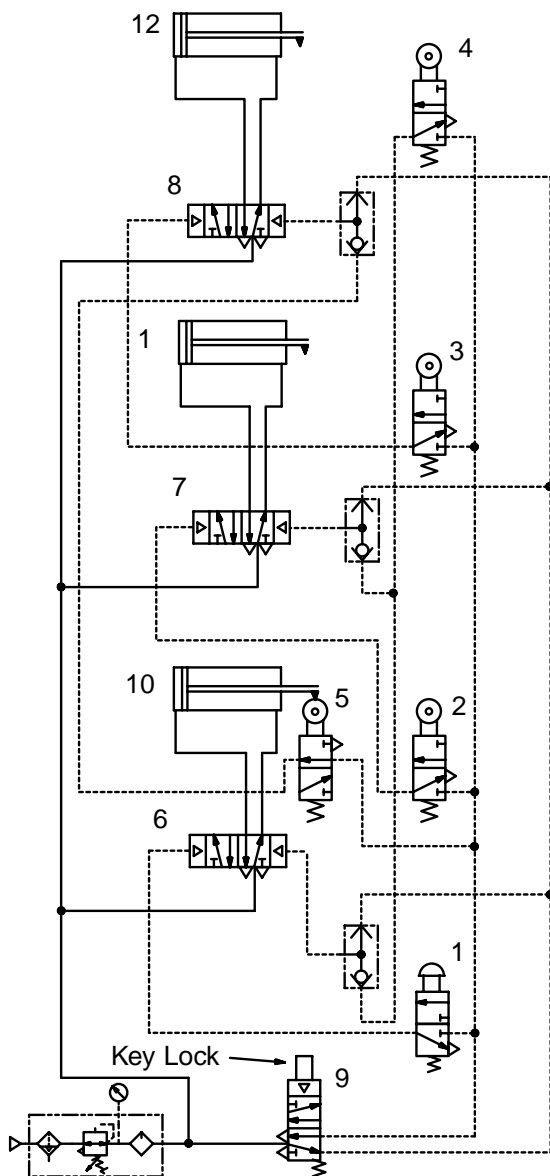

7. What components should be placed in boxes A and B to decelerate the cylinder near the end of the extension stroke?
- Valve 2 in box A, valve 1 in box B.
 - Valve 1 in box A, valve 2 in box B.
 - Valve 2 in box A, valve 5 in box B.
 - Valve 1 in box A, valve 6 in box B.
 - Valve 2 in box A, valve 2 in box B

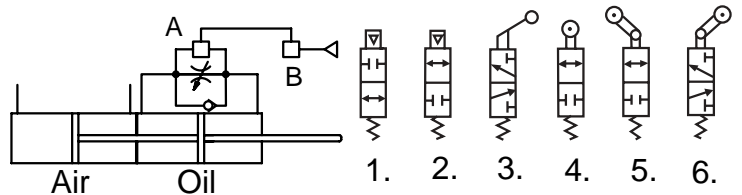

8. What is likely to happen if Valve 2 is not released before Valve 3 is actuated?
- Both cylinders will retract and then extend.
 - Cylinder #1 will retract.
 - One cylinder will extend.
 - Both cylinders will stay retracted.
 - Both cylinders will extend.

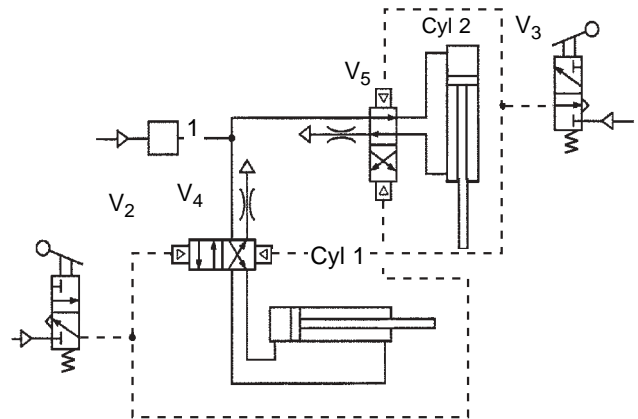

9. In the example shown, if the maximum spring return force were 25 lbs, what minimum theoretical air pressure would be required to move a 75 lb load up the conveyor ramp using a 2 inch bore cylinder?
- 12 psig
 - 20 psig
 - 32 psig
 - 40 psig
 - 45 psig

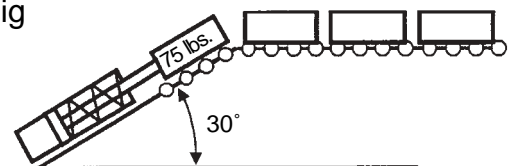

Pneumatic Specialist Certification Pre-Test - 2

10. An air compressor delivers 10 scfm. At 120 psig, how many times per minute would this cycle a single-acting air cylinder with a 2 inch bore traveling through a 4 inch stroke? Neglect the retraction time.
- 50 cpm
 - 75 cpm
 - 100 cpm
 - 125 cpm
 - 150 cpm
11. If the rotary actuator shown below operates on 100 psig. air pressure, what diameter pistons would be necessary for motor to exert a theoretical torque of 150 lb-ft?
- 1.69 in
 - 2.39 in
 - 2.88 in
 - 3.38 in
 - 4.50 in

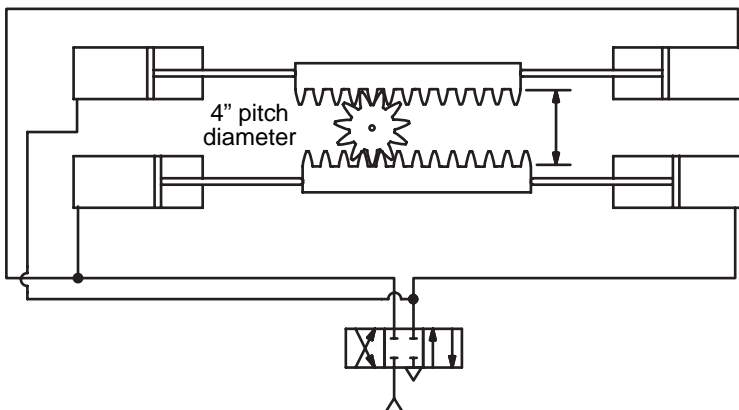

12. An air valve delivers 35 scfm at 70 °F with a supply pressure of 80 psig. If the valve has an 8 psi pressure drop, what is the C_v for the valve?
- 1.08
 - 1.29
 - 1.35
 - 1.40
 - 1.48
13. Which one of the following components removes the most water from compressed air?
- Intercooler
 - After cooler
 - Receiver
 - First stage
 - Inlet filter

14. The noise from a venturi vacuum pump is controlled by the:
- silencer
 - plumbing
 - inlet filter
 - venturi location
 - vacuum chamber
15. What happens if the emergency retract button is pressed when cylinder 1 rod is fully extended?
- The circuit stops immediately.
 - Cylinder 1 retracts, then the circuit stops.
 - The circuit completes the normal cycle.
 - Cylinder 1 stops, cylinder 2 extends, then the circuit stops.
 - Cylinder 1 retracts, cylinder 2 extends, then the circuit stops.

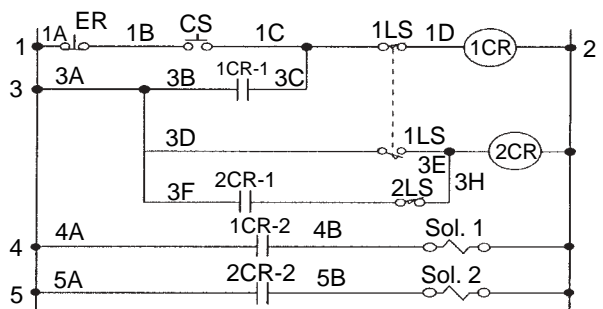
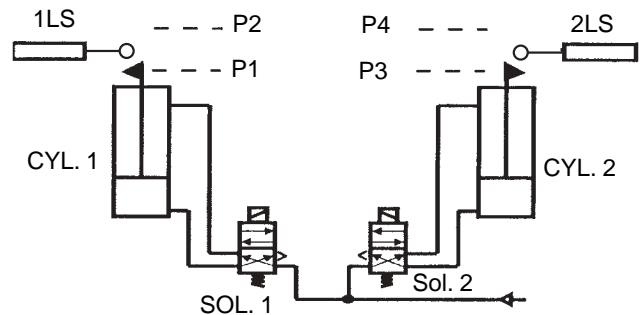

16. A 0 to 150 psig pressure transducer which produces a 4 to 20 milliamp signal is connected to a matching digital display. If the display shows 90 psig, what is the current from the transducer?
- 9.6 milliamps
 - 12.0 milliamps
 - 13.6 milliamps
 - 16.0 milliamps
 - 17.5 milliamps

Pneumatic Specialist Pre-Test - 2 Answer Sheet

| Outcome: | Load and Motion Analysis | Page | Answers |
|--|---|-------------|----------------|
| 1. | Solves formulas for torque, speed and horsepower of an air motor connected through a reduction system to a conveyor. | 11 | 1. A B C D E |
| 3. | Computes the bore diameter and pressure for a cylinder to move loads with a friction factor. | 16 | 2. A B C D E |
| 5. | Computes the sheer strength of fixture attachments to retain rodless cylinder couplings under load. | 20 | 3. A B C D E |
| System Analysis and Troubleshooting | | | |
| 8. | Converts pressure readings between inches of water and inches of mercury. | 23 | 4. A B C D E |
| 11. | Predicts the operation of a pneumatic system by tracing the path of air flowing through circuits when various commands are given. | 29 | 5. A B C D E |
| 14. | Predicts operation of a pneumatic system when special commands are given (System shutdown, Emergency Stop, Error Signal). | 33 | 6. A B C D E |
| System Design | | | |
| 17. | Selects the location of various components in a circuit to achieve a deceleration function. | 38 | 7. A B C D E |
| 20. | Selects input components to achieve a desired operation in a pneumatic circuit. | 41 | 8. A B C D E |
| Component Application | | | |
| 22. | Computes the pressure required to extend a loaded cylinder operating on an incline. | 44 | 9. A B C D E |
| 24. | Computes the cfm of air flow to power an air cylinder. | 47 | 10. A B C D E |
| 28. | Calculates the torque output from a rack and pinion gear mechanism driven by two air cylinders. | 54 | 11. A B C D E |
| 32. | Calculates the C_v for an air valve from pressure, flow and temperature conditions. | 60 | 12. A B C D E |
| Air Compression and Preparation | | | |
| 36. | Associates pneumatic components with their functions. | 66 | 13. A B C D E |
| 40. | Recognizes the operational characteristics of various types of vacuum generators. | 74 | 14. A B C D E |
| Control Components and Systems | | | |
| 44. | Identifies probable causes of pneumatic circuit failure from symptoms sequence of circuit operations, circuit drawing and electrical schematic. | 80 | 15. A B C D E |
| 48. | Computes the current output from a pressure transducer signal and transducer characteristics. | 86 | 16. A B C D E |

Pneumatic Specialist Certification Pre-Test - 3

1. What torque could be expected from an air motor that is rated at 2.5 hp at 2250 rpm?
 - a. 0.93 lb-ft
 - b. 1.07 lb-ft
 - c. 1.97 lb-ft
 - d. 5.84 lb-ft
 - e. 8.45 lb-ft

2. A 750 lb load is to be pushed up a 30° incline by an air cylinder with a 4 inch bore. If the coefficient of friction between the surface and the load is 0.35, what minimum air pressure will be required to extend the cylinder to move the load?
 - a. 24 psig
 - b. 35 psig
 - c. 48 psig
 - d. 85 psig
 - e. 109 psig

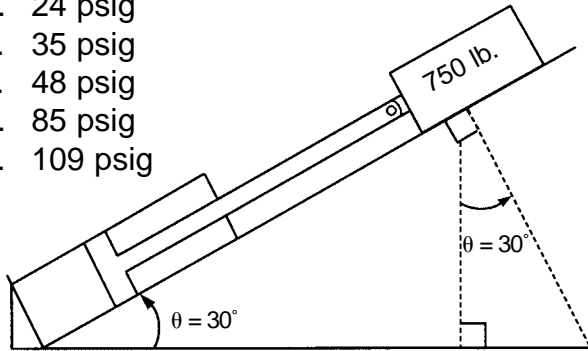

3. If in the figure below, the angle between the cylinder rod and boom is 30°, what minimum theoretical pressure would there be in a cylinder with a 3 inch bore?
 - a. 35 psig
 - b. 50 psig
 - c. 85 psig
 - d. 170 psig
 - e. 185 psig

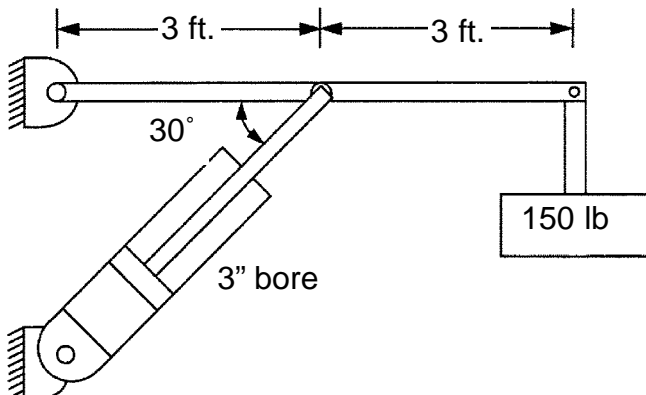

4. An 1/4 hp air motor is selected to operate at 1200 rpm. Using various calculations and the graphs below, what minimum air pressure listed would be required?
 - a. 30 psig
 - b. 40 psig
 - c. 50 psig
 - d. 60 psig
 - e. 70 psig

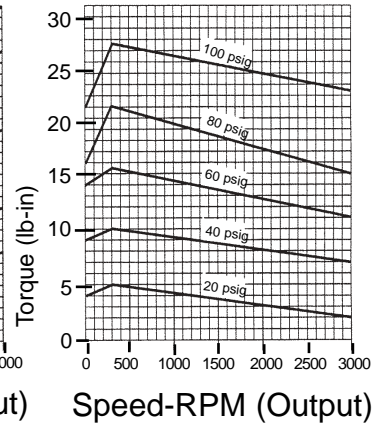
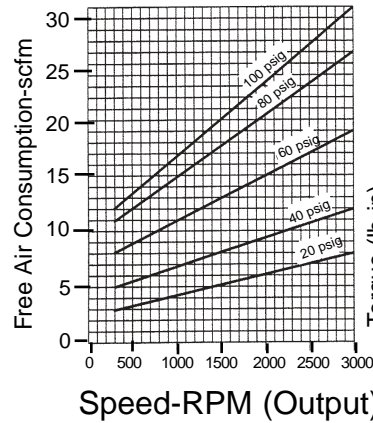

Pneumatic Specialist Certification Pre-Test - 3

5. With key lock valve 9 in the actuated position, if start valve 1 is depressed and held depressed, what would be the final position of cylinders 10, 11, and 12?
- Cylinder 10 extended, cylinder 11 extended, cylinder 12 extended.
 - Cylinder 10 retracted, cylinder 11 retracted, cylinder 12 retracted.
 - Cylinder 10 extended, cylinder 11 retracted, cylinder 12 extended.
 - Cylinder 10 retracted, cylinder 11 extended, cylinder 12 retracted.
 - Cylinder 10 extended, cylinder 11 extended, cylinder 12 retracted.

6. Referring to the figure below, which valve configuration would require the lowest pressure while the load is being lifted?
- Remove the flow control at valve B.
 - Reverse flow control check at valve A.
 - Reverse flow control check at valve B.
 - Reverse flow control checks at valves A and B.
 - Leave flow control valves A and B as they are.

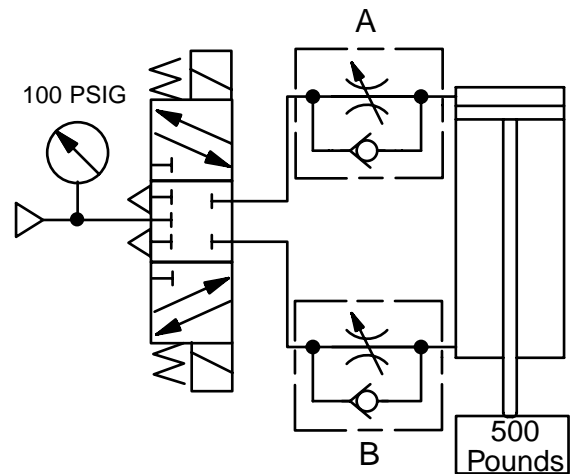
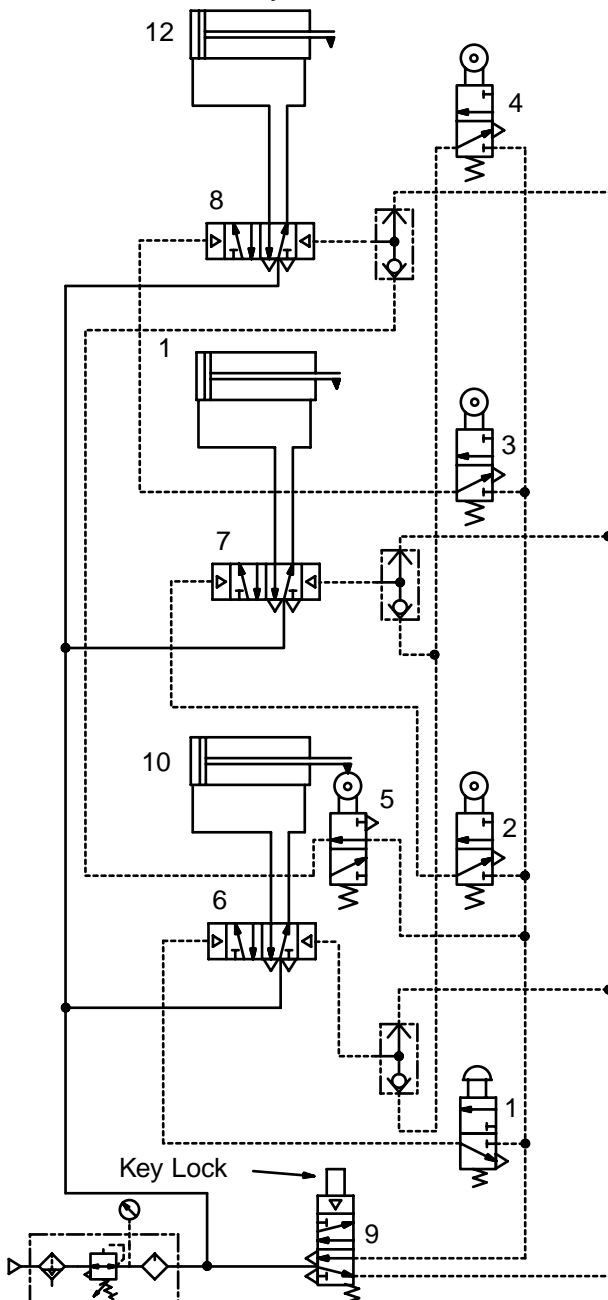

Pneumatic Specialist Certification Pre-Test - 3

7. What minimum size pipe will deliver compressed air supplied at 80 psig to an air tool rated at 11 scfm 100 ft away with a pressure drop of 10% or less?
- 1/8 in.
 - 1/4 in.
 - 3/8 in.
 - 1/2 in.
 - 3/4 in.
9. Which one of the following is an advantage of a single-acting, gravity returned, air cylinder over a double-acting air cylinder?
- Less expensive to operate.
 - Smaller bore can be used.
 - More noise during operation.
 - Less wear than double-acting.
 - Cycle rate is faster during operation.

| Applied Pressure (psig) | NORMAL STANDARD PIPE SIZE | | | | | | | | | | |
|-------------------------|---------------------------|------|------|-------|-------|-----|--------|--------|------|--------|------|
| | 1/8" | 1/4" | 3/8" | 1/2" | 3/4" | 1" | 1-1/4" | 1-1/2" | 2" | 2-1/2" | 3" |
| 5 | 0.5 | 1.2 | 2.7 | 4.9 | 6.6 | 13 | 27 | 40 | 80 | 135 | 240 |
| 10 | 0.8 | 1.7 | 3.9 | 7.7 | 11.0 | 21 | 44 | 64 | 125 | 200 | 370 |
| 20 | 1.3 | 3.0 | 6.6 | 13.0 | 18.5 | 35 | 75 | 110 | 215 | 350 | 600 |
| 40 | 2.5 | 5.5 | 12.0 | 23.0 | 34.0 | 62 | 135 | 200 | 385 | 640 | 1100 |
| 60 | 3.5 | 8.0 | 18.0 | 34.0 | 50.0 | 93 | 195 | 290 | 560 | 900 | 1600 |
| 80 | 4.7 | 10.5 | 23.0 | 44.0 | 65.0 | 120 | 255 | 380 | 720 | 1200 | 2100 |
| 100 | 5.8 | 13.0 | 29.0 | 54.0 | 80.0 | 150 | 315 | 470 | 900 | 1450 | 2600 |
| 150 | 8.6 | 20.0 | 41.0 | 80.0 | 115.0 | 220 | 460 | 680 | 1350 | 2200 | 3900 |
| 200 | 11.5 | 26.0 | 58.0 | 108.0 | 155.0 | 290 | 620 | 910 | 1750 | 2800 | 5000 |
| 250 | 14.5 | 33.0 | 73.0 | 135.0 | 200.0 | 370 | 770 | 1150 | 2200 | 3500 | 6100 |

Tabled values are flow rates in SCFM. Pressure drop per 100 ft. of pipe is based on 10% of applied pressure for 1/8 in., 1/4 in., 3/8 in., and 1/2 in.; and 5% of applied pressure for 3/4 in., 1 in., 1-1/4 in., 1-1/2 in., 2 in., 2-1/2 in., and 3 in.

8. Which one of the following components placed in Block 1 will have the least effect on operation of the air circuit shown?
- Pressure regulator.
 - Pressure gauge.
 - Lubricator.
 - Slow-start valve.
 - Two way valve
10. Ignoring friction, what theoretical air pressure would be required to hold a load of 50 lbs suspended, if the air cylinder has a 2 inch bore and 1 inch diameter rod?
- 100 psig
 - 128 psig
 - 175 psig
 - 250 psig
 - 316 psig

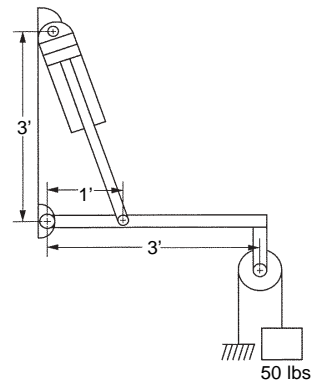
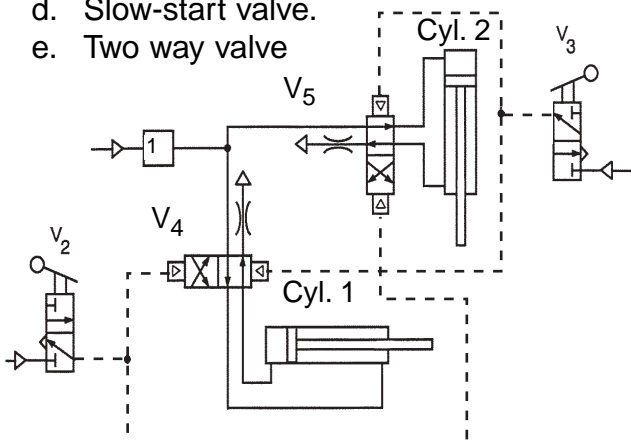

Pneumatic Specialist Certification Pre-Test - 3

11. If the crate shown weighs 40 lbs and it takes 3 seconds to slide down the 10 foot ramp onto the main conveyor, what is the kinetic energy that must be absorbed by the shock absorber? Assume the load accelerates uniformly onto the conveyor.
- 5.59 ft-lb.
 - 27.63 ft-lb.
 - 60.64 ft-lb.
 - 72.58 ft-lb.
 - 97.53 ft-lb.

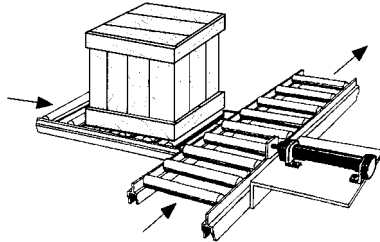

12. The upstream pressure against an orifice is 125 psig. If the flow rate is 20 scfm at 60 psig, what happens to the flow if the downstream pressure decreases to 40 psig
- is cut in half.
 - decreases linearly.
 - increases slightly.
 - increases linearly.
 - doubles.
13. If a filter element with a 40 micron rating is replaced with an element that has an 80 micron rating, the:
- downstream pressure will drop.
 - upstream pressure will increase.
 - downstream flow will drop.
 - downstream flow will increase.
 - pressure and flow will remain the same.

14. If the circuit shown in the figure has a cylinder stroke of 14 inches, and the linear transducer has a range of 0 to -12 volts, what would be the approximate position of the cylinder rod when the control voltage shows 7 volts?
- 2.5 in. retracted.
 - 6.8 in. extended.
 - 8.2 in. extended.
 - 9.4 in. extended.
 - 5.0 in. retracted.

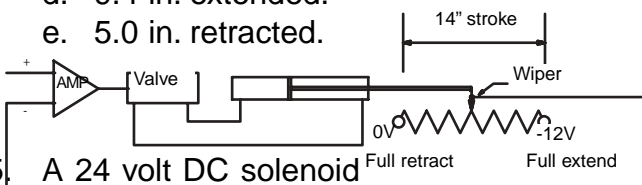

15. A 24 volt DC solenoid

- rated at 6 watts is wired in parallel with two resistance indicator lights that are wired in series with each other. One light is located at the solenoid, the other light is located at an operator's station. If each indicator light consumes 0.25 watts, calculate the total resistance for the circuit.
- 76.7 ohms
 - 88.6 ohms
 - 98.4 ohms
 - 108.5 ohms
 - 125.6 ohms

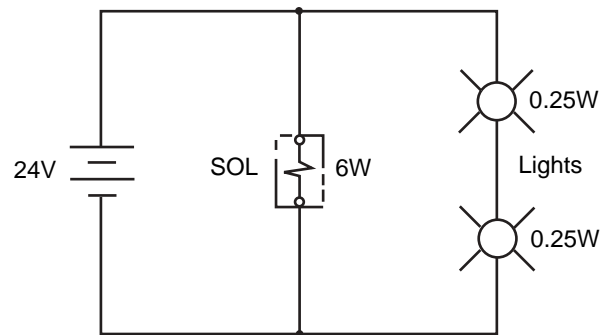

16. A 20 inch stroke cylinder is equipped with a digital linear transducer which has a 8 bit output. What is the resolution?
- 0.019 in.
 - 0.039 in.
 - 0.078 in.
 - 0.156 in.
 - 0.312 in.

Pneumatic Specialist Pre-Test - 3 Answer Sheet

Load and Motion Analysis

| Outcome: | Page | Answers |
|---|------|--------------|
| 1. Solves formulas for torque, speed and horsepower of an air motor connected through a reduction system to a conveyor. | 11 | 1. A B C D E |
| 3. Computes the bore diameter and pressure for a cylinder to move loads with a friction factor (Coefficient of Friction). | 16 | 2. A B C D E |

System Analysis and Troubleshooting

| | | |
|---|----|--------------|
| 6. Computes the air cylinder pressure required to support jib-boom loads. | 21 | 3. A B C D E |
| 9. Uses manufacturer's graphs and formulas to determine cfm requirements for an air motor. | 24 | 4. A B C D E |
| 11. Predicts the operation of a pneumatic system by tracing the path of air flowing through various circuits when various commands are given. | 29 | 5. A B C D E |

System Design

| | | |
|--|----|--------------|
| 15. Selects the appropriate solution to control air cylinder velocity. | 35 | 6. A B C D E |
| 18. Selects conductor sizes from application charts given pressure, flow delivery and line length. | 39 | 7. A B C D E |
| 20. Selects input components to achieve a desired operation in a pneumatic circuit. | 41 | 8. A B C D E |

Component Application

| | | |
|---|----|---------------|
| 23. Recognizes the advantages and disadvantages of single-acting and double-acting cylinders. | 45 | 9. A B C D E |
| 25. Computes the cylinder bore diameter for a load attached to a cylinder through a system of levers and pulleys. | 48 | 10. A B C D E |
| 29. Calculates the kinetic energy required to stop a load with a shock absorber. | 55 | 11. A B C D E |
| 33. Recognizes that the critical (sonic) velocity through an orifice is reached when the downstream pressure is 53% of the upstream pressure, and at the critical velocity, increasing the pressure drop across the orifice will not increase air flow. | 62 | 12. A B C D E |

Air Compression and Preparation

| | | |
|--|----|---------------|
| 37. Identifies characteristics of air filter elements. | 68 | 13. A B C D E |
| 41. Computes the operational characteristics of a position feedback circuit. | 76 | 14. A B C D E |

Control Components and Systems

| | | |
|---|----|---------------|
| 45. Applies Ohm's Law and Kirchoff's Law to solenoid electrical circuits. | 82 | 15. A B C D E |
| 49. Computes the resolution for digital linear transducers from the signal input characteristics. | 87 | 16. A B C D E |

Pneumatic Specialist Certification Pre-Test - 4

1. What torque could be expected from an air motor that is rated at 4 kw at 2400 rpm?
 - a. 6.62 N-m
 - b. 8.85 N-m
 - c. 11.73N-m
 - d. 11.87 N-m
 - e. 15.92 N-m

4. If an air motor operates under load at 2000 rpm develops 17 lb-in. of torque, approximately how much air in scfm will it consume?
 - a. 10 scfm
 - b. 15 scfm
 - c. 20 scfm
 - d. 25 scfm
 - e. 30 scfm

2. A 2500 lb load is to be moved down a 45° incline by extending an air cylinder. If the coefficient friction between the surface and the load is 0.28, what load will be placed on the cylinder?
 - a. - 495 lbs
 - b. - 1068 lbs
 - c. - 1278 lbs
 - d. - 1821 lbs
 - e. - 2263 lbs

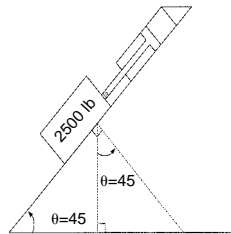

3. How much pressure drop in in-Hg. would be required to lift a car hood weighing 120 lbs using two 4 inches diameter vacuum cups? Allow a safety factor of 2.
 - a. 9.55 in-Hg pressure drop.
 - b. 14.68 in-Hg pressure drop.
 - c. 15.63 in-Hg pressure drop.
 - d. 19.44 in-Hg pressure drop.
 - e. 28.00 in-Hg pressure drop.

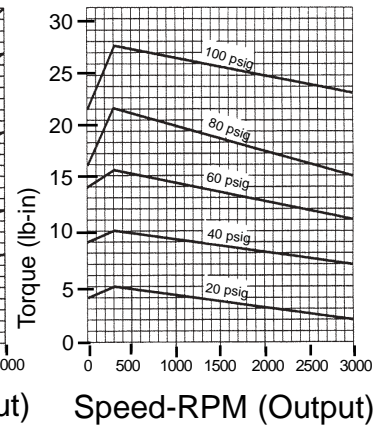
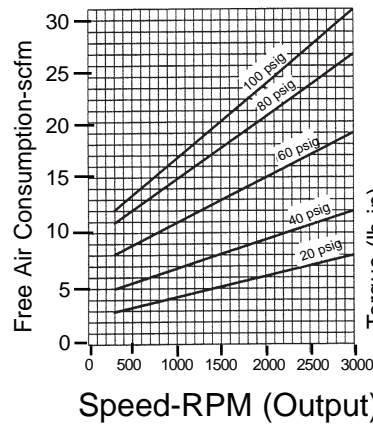

Pneumatic Specialist Certification Pre-Test - 4

5. How would the circuit shown below operate if limit valve 2 were to stick passing with key lock valve 9 in the run position, and after start valve 1 was depressed and released?
- Cylinder 10 would not retract.
 - Cylinder 11 would not retract.
 - Cylinder 12 would not retract.
 - Cylinders 11 and 12 would retract.
 - Cylinders 11 and 12 would not retract.

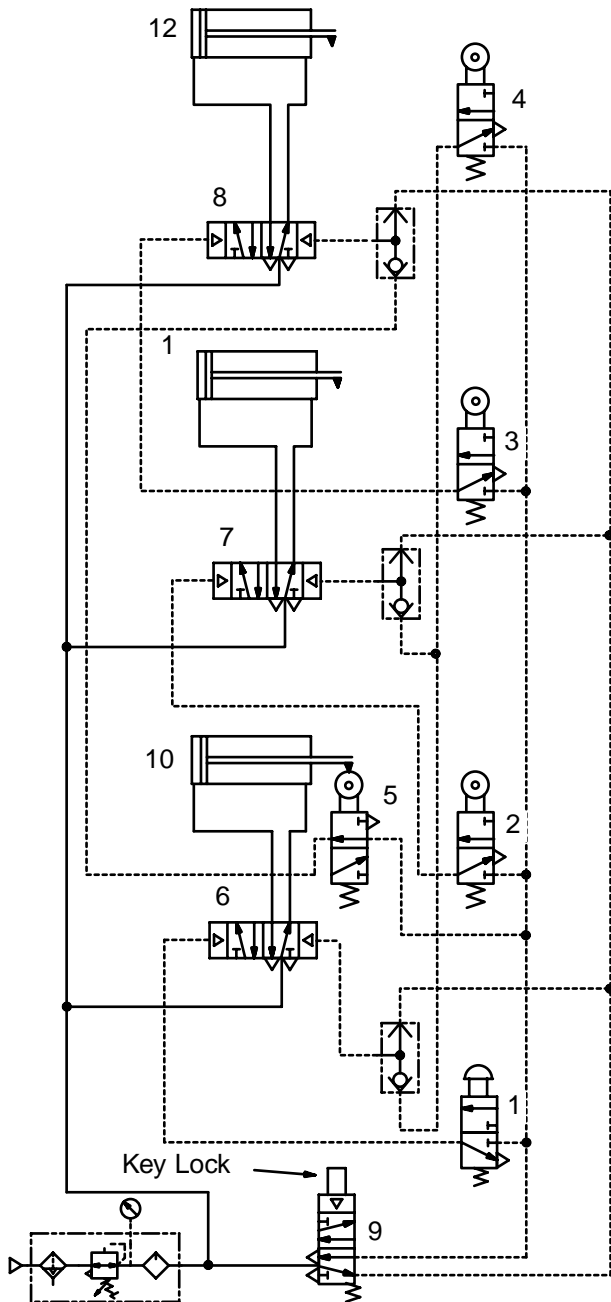

6. A single-acting piston (spring return) type air-oil intensifier with a 3 inch diameter bore and 1.5 inch stroke powers an oil piston intensifier with a 0.5 inch diameter bore. How many scfm of air would be required to deliver 1/4 gpm oil at a pressure of 4000 psig? (Ignore the pressure required to compress the return spring.)
- 8.56 scfm
 - 10.31 scfm
 - 18.22 scfm
 - 20.63 scfm
 - 24.65 scfm

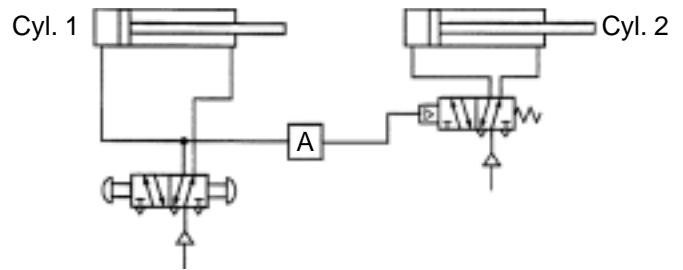

7. How many gallons capacity would a receiver have to be to supply 10 scfm of air between 160 psig and 140 psig for 3 minutes? Assume that the temperature remains constant.
- 120 gal
 - 165 gal
 - 185 gal
 - 210 gal
 - 300 gal
8. Under what conditions would the circuit fail to protect the operator from the cylinder while it is extending?
- Tying down V1 and V2.
 - Depressing V2 but not V1.
 - Tying down V1 and depressing V2.
 - Depressing V1 and V2, then releasing V2.
 - Depressing V1 and V2, then releasing V1.

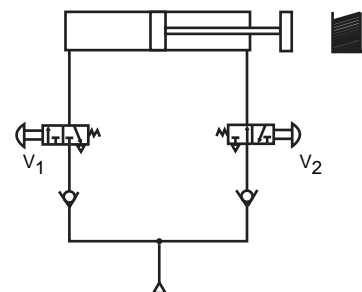

Pneumatic Specialist Certification Pre-Test - 4

9. Which one of the following is an advantage of a double-acting air cylinder over a single-acting air cylinder?
- Mid-stroke positioning.
 - Meter-in control of the load.
 - Controlable force in both directions.
 - Less expensive to manufacture.
 - Less expensive valving may be used.
10. A double-acting single rod cylinder with a 3 inch bore and 1 inch diameter rods extends through a 24 inch stroke while producing a 400 force, and retracts through the same stroke producing 600 lb force. If extension time is 2 seconds plus a 1 second dwell, and reaction time is 3 seconds plus a 4 second dwell, how many scfm are required to power the air cylinder. Friction forces are included in the values given.
- 4.4 scfm
 - 9.3 scfm
 - 15.1 scfm
 - 19.6 scfm
 - 27.1 scfm
11. Which method of reducing shock could build pressure surges in the cylinder?
- Stop tube.
 - External bumper.
 - Internal shock pad.
 - Adjustable air cushion.
 - Air-oil cylinder arrangement.
12. A directional control valve directs air to a bi-directional motor which consumes 30 scfm at 90 psig. If air is available at the valve inlet at 100 psig and 90°F, what is the required valve C_v ?
- 0.398
 - 0.492
 - 0.702
 - 0.928
 - 0.959
13. Which one of the following will provide the best solution to lack of lubrication at an air cylinder?
- Increase line pressure.
 - Locate a flow control at the cylinder port.
 - Increase tubing diameter.
 - Install a quick exhaust valve at the cylinder.
 - Increase lubrication adjustment
14. The voltmeter in the following circuit should read:
- 2 volts
 - 3.2 volts
 - 4 volts
 - 6 volts
 - 12 volts

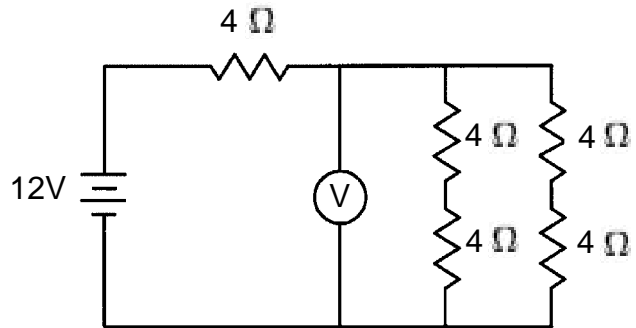

15. A pulse width modulated signal controls downstream air pressure from an upstream air source at 120 psig. If the signal begins to open the regulator at 20% ON and is wide open at 80% ON, what would be the pressure downstream of the valve when the signal is at 60%.
- 20 psig
 - 50 psig
 - 60 psig
 - 80 psig
 - 84 psig
16. If the input/output modules for a programmable logic controller (PLC) are located near the actuator, how many wires are required between the PLC and the multiplexer for a remote valve manifold that has 12 double solenoid directional control valves?
- 1
 - 2
 - 9
 - 16
 - 25

Pneumatic Specialist Certification Pre-Test - 4

| Outcome: | Load and Motion Analysis | Page | Answers |
|--|---|-------------|----------------|
| 1. | Solves formulas for torque, speed and horsepower of an air motor connected through a reduction system to a conveyor. | 11 | 1. A B C D E |
| 3. | Computes bore diameter and pressure for a cylinder to move loads with a friction factor (Coefficient of Friction). | 16 | 2. A B C D E |
| System Analysis and Troubleshooting | | | |
| 7. | Solves for the pressure and suction area to provide a required lifting force using vacuum cups. | 22 | 3. A B C D E |
| 9. | Uses manufacturer's graphs and formulas to determine cfm requirements for an air motor. | 24 | 4. A B C D E |
| 12. | Predicts the operation of a pneumatic system by tracing a malfunction to a faulty component. | 31 | 5. A B C D E |
| System Design | | | |
| 27. | Calculates the oil flow rate and pressure from a pneumatic intensifier. | 52 | 6. A B C D E |
| 19. | Uses formulas to size air receivers to perform various functions. | 40 | 7. A B C D E |
| 21. | Identifies the most and least important safety considerations in the design of an air circuit. | 42 | 8. A B C D E |
| Component Application | | | |
| 23. | Recognizes the advantages and disadvantages of single-acting and double-acting cylinders. | 45 | 9. A B C D E |
| 26. | Calculates the scfm of air flow to power a single rod cylinder with extension and retraction forces and cylinder times specified. | 51 | 10. A B C D E |
| 30. | Recognizes the characteristics of stop tubes and cushioning devices. | 57 | 11. A B C D E |
| 32. | Calculates the C_v to size a directional control (power) valve for an air motor. | 62 | 12. A B C D E |
| Air Compression and Preparation | | | |
| 38. | Recognizes the application characteristics of pneumatic components. | 70 | 13. A B C D E |
| Control Components and Systems | | | |
| 45. | Applies Ohm's Law and Kirchoff's Law to solve series-parallel circuits for voltage, current and resistance. | 82 | 14. A B C D E |
| 46. | Determines the cycle characteristics for pulse width modulated (PWM) pressure control valve. | 83 | 15. A B C D E |
| 50. | Matches appropriate wiring arrangements between PLC's and directional control valves. | 88 | 16. A B C D E |

Pneumatic Specialist Pre-Test Answer Key

Pneumatic Specialist Pre-Test Answer Key

| <u>PS-1</u> | <u>PS-2</u> | <u>PS-3</u> | <u>PS-4</u> |
|-------------|-------------|-------------|-------------|
| 1. E | 1. D | 1. D | 1. E |
| 2. D | 2. A | 2. C | 2. C |
| 3. B | 3. A | 3. C | 3. D |
| 4. D | 4. E | 4. D | 4. C |
| 5. E | 5. A | 5. A | 5. E |
| 6. D | 6. C | 6. B | 6. B |
| 7. D | 7. D | 7. C | 7. B |
| 8. B | 8. D | 8. B | 8. C |
| 9. D. | 9. B | 9. A | 9. C |
| 10. E | 10. E | 10. B | 10. C |
| 11. B | 11. B | 11. B | 11. D |
| 12. A | 12. C | 12. C | 12. E |
| 13. C | 13. B | 13. D | 13. D |
| 14. A | 14. A | 14. C | 14. D |
| 15. C | 15. C | 15. B | 15. D |
| 16. C | 16. C | 16. C | 16. B |

FLUID POWER CERTIFICATION

Setting competitive standards for Fluid Power Professionals

Fluid Power Certification ... How Can I Benefit?

Fluid Power Certification is a fast-growing educational movement in the industry today - and it's not surprising why.

Much of the traditional training from manufacturers, technical schools, and universities has been of high quality, but limited in its availability. Consequently, few of the 350,000 people working in the industry have been able to take full advantage of Fluid Power training. Many of today's fluid power professionals learned about the technology on the job and often did not receive the recognition they deserved for their educational accomplishments.

If the majority of your professional training was on-the-job or limited to short courses and workshops, then fluid power certification may be just what you need to stay competitive in today's marketplace. Fluid power certification gives you an opportunity to demonstrate your extraordinary effort to enhance your professionalism through education, training, and peer review. It may provide you with the credential you need to open the door for career advancement. For fluid power distributors, manufacturers and end-users, certification offers a multitude of benefits:

- ◆ Provides another measure with which to assess new employees.
- ◆ Establishes a minimal level of Fluid Power knowledge and skills.
- ◆ Educates your customers - so you don't have to.
- ◆ Helps satisfy requirements for employee qualifications.
- ◆ Demonstrates an individual's efforts to achieve and maintain the highest professional proficiency available in the industry.

What's Involved in Certification?

Fluid power certification consists of an optional review session, followed by a three-hour written test and recognition upon successful completion. For Mechanics' and Technicians' certification, an additional three-hour job performance test is also required.

How Many Kinds of Tests Are Offered?

The Fluid Power Certification Board currently offers nine Certification Tests at four levels:

◆ **Mechanic:** fabricates, assembles, tests, maintains and repairs systems and components, etc.

• **Master Mechanic**

- Mobile Hydraulic Mechanic
- Industrial Hydraulic Mechanic
- Pneumatic Mechanic

◆ **Technician:** troubleshoots systems, tests and modifies systems, prepares reports, etc.

• **Master Technician**

- Mobile Hydraulic Technician
- Industrial Hydraulic Technician
- Pneumatic Technician

◆ **Specialist:** analyzes and designs systems, selects components, instructs others in operations and maintenance, etc.

• **Fluid Power Specialist**

- Hydraulic Specialist
- Pneumatic Specialist

◆ **Engineer:** has a technology or engineering degree or is a current Professional Engineer, has eight years of work experience and has passed the Hydraulic & Pneumatic Specialist exams.

What Technologies are Covered by the Tests?

Fluid power and motion control technologies include questions on hydraulics, pneumatics, electronic control, and vacuum.

Who May Organize a Review Training Session?

Educational institutions, end-user companies, fluid power distributors, fluid power component manufacturers, for-profit educational organizations and the Fluid Power Society (local chapters or the national Headquarters), can organize review training sessions.

Who Administers the Tests?

Written testing is conducted under the supervision of local proctors retained by the Fluid Power Certification Board. Job performance testing may only be administered by an FPS Accredited Instructor. Tests are scheduled throughout the world in over 138 cities throughout the year.

How Will My Accomplishments be Recognized?

Certified fluid power professionals are encouraged to include their certification on their business cards and letterhead - even on work vehicle signage. Certification patches are also available for use on uniforms, as well as other promotional items. All Certified Professionals receive a certificate suitable for framing, wallet card, are recognized in the Fluid Power Journal, are listed in the annual Certification Directory, and on the Fluid Power Society's web site.

Will I Have to Renew My Certification?

Yes - Certifications are valid for five years. After that time, you must apply for re-certification based on a point system. On the re-certification form, you will be asked to list job responsibilities, additional educational courses you have taken or taught, and professional involvement in Fluid Power or allied organizations.

What Will This Cost Me?

The Fluid Power Certification Board has made every effort to keep costs low and make Certification available to as many fluid power professionals as possible. Many manufacturers and distributors subsidize or even reward this program because it provides a great return on investment. A contribution to the fluid power certification program helps upgrade the skills of those professionals committed to the industry and elevates the level of professionalism throughout the entire Fluid Power Industry.

How Can I Receive More Information?

For fee schedules, review sessions, manuals and other information, please visit our web site at www.IFPS.org, contact Headquarters at 1-800-303-8520, or write to:

Fluid Power Certification Board

3245 Freemansburg Avenue
Palmer, PA 18046-7118

Phone: 800-303-8520, 610-923-0386;

Fax: 610-923-0389 E-mail:

FPS@IFPS.org

Web: <http://www.IFPS.org>

Fluid Power Certification Board

Certification Coordinator c/o FPS, 3245 Freemansburg Ave., Palmer, PA 18045-7118. Phone: 610-923-0386. Fax: 610-923-0389

Certification Test Application

You have three years from date of application to take the test, after which fees are forfeited.

Please fully complete form.

Preferred mailing address: Home Work

Name _____

Employer _____

Home Address _____

Work Address _____

City _____ State _____ Zip _____

City _____ State _____ Zip _____

Phone _____ Fax _____

Phone _____ Fax _____

E-mail address _____

E-mail address _____

FPS Member I.D. # _____

Present Job/Title _____

Social Security Number (Serves as your Test ID Number) _____

Full Time Student

(Send proof of Full Time status with application - 12 Credits)

Education Information: (Check highest level attained)

Grade School Years _____

High School Years _____ Diploma _____

Technical Institute Years _____ Degree _____

College Years _____ Degree _____

NOTE
Payment Required
with Application
for application to be processed

Which test do you intend to take? (Check one)

- | | | |
|---|---|---|
| <input type="checkbox"/> Mobile Hydraulic Mechanic* | <input type="checkbox"/> Mobile Hydraulic Technician* | <input type="checkbox"/> Hydraulic Specialist |
| <input type="checkbox"/> Industrial Hydraulic Mechanic* | <input type="checkbox"/> Industrial Hydraulic Technician* | <input type="checkbox"/> Pneumatic Specialist |
| <input type="checkbox"/> Pneumatic Mechanic* | <input type="checkbox"/> Pneumatic Technician* | <input type="checkbox"/> Engineer (separate application required) |
| <input type="checkbox"/> Job Performance Only – Hydraulic or Pneumatic (Circle One) | | *Requires the Job Performance Test |

Test Date: _____ Test Site: _____

| Item | Amount |
|---|--------|
| Test Fee | |
| Full Time Student Test Fee | |
| Retake Fee — Written Test | |
| Retake Fee — Job Performance Test | |
| Certification Manual # | |
| Test Reschedule Fee (Refer to Policies) | |
| TOTAL DUE | |

| For Office Use Only |
|---------------------|
| Member #: |
| Prior Tests: |
| |
| |
| |
| Fee Received: |
| |
| |

Payment Required with Application for application to be processed.

Payment Type:

- Check or Money Order Enclosed (in U.S. funds only)
 Credit Card (MasterCard or Visa Only) (Required)

Type of Card: MC VISA Credit Card Number _____ Exp. Date _____

Signature _____

Revised 29 March 2000