**Hydraulic fluid power — Mounting
dimensions for single rod cylinders,
16 MPa (160 bar) series —**

**Part 1:
Medium series**

*Transmissions hydrauliques — Dimensions d'interchangeabilité des
vérins 16 MPa (160 bar) à simple tige —*

Partie 1: Série moyenne



PDF disclaimer

This PDF file may contain embedded typefaces. In accordance with Adobe's licensing policy, this file may be printed or viewed but shall not be edited unless the typefaces which are embedded are licensed to and installed on the computer performing the editing. In downloading this file, parties accept therein the responsibility of not infringing Adobe's licensing policy. The ISO Central Secretariat accepts no liability in this area.

Adobe is a trademark of Adobe Systems Incorporated.

Details of the software products used to create this PDF file can be found in the General Info relative to the file; the PDF-creation parameters were optimized for printing. Every care has been taken to ensure that the file is suitable for use by ISO member bodies. In the unlikely event that a problem relating to it is found, please inform the Central Secretariat at the address given below.



COPYRIGHT PROTECTED DOCUMENT

© ISO 2007

All rights reserved. Unless otherwise specified, no part of this publication may be reproduced or utilized in any form or by any means, electronic or mechanical, including photocopying and microfilm, without permission in writing from either ISO at the address below or ISO's member body in the country of the requester.

ISO copyright office
Case postale 56 • CH-1211 Geneva 20
Tel. + 41 22 749 01 11
Fax + 41 22 749 09 47
E-mail copyright@iso.org
Web www.iso.org

Published in Switzerland

Licensed to: Rockhill, Denise Ms
Downloaded: 2017-01-19
Single user licence only, copying and networking prohibited

Contents

Page

Foreword	iv
Introduction	v
1 Scope	1
2 Normative references	1
3 Terms and definitions	2
4 Dimensions	2
5 Bore sizes	2
6 Stroke tolerances	2
7 Mounting types	2
8 Piston rod characteristics	3
9 Identification statement (reference to this part of ISO 6020)	3
Bibliography	12

Foreword

ISO (the International Organization for Standardization) is a worldwide federation of national standards bodies (ISO member bodies). The work of preparing International Standards is normally carried out through ISO technical committees. Each member body interested in a subject for which a technical committee has been established has the right to be represented on that committee. International organizations, governmental and non-governmental, in liaison with ISO, also take part in the work. ISO collaborates closely with the International Electrotechnical Commission (IEC) on all matters of electrotechnical standardization.

International Standards are drafted in accordance with the rules given in the ISO/IEC Directives, Part 2.

The main task of technical committees is to prepare International Standards. Draft International Standards adopted by the technical committees are circulated to the member bodies for voting. Publication as an International Standard requires approval by at least 75 % of the member bodies casting a vote.

Attention is drawn to the possibility that some of the elements of this document may be the subject of patent rights. ISO shall not be held responsible for identifying any or all such patent rights.

ISO 6020-1 was prepared by Technical Committee ISO/TC 131, *Fluid power systems*, Subcommittee SC 3, *Cylinders*.

This third edition cancels and replaces the second edition (ISO 6020-1:1998) and ISO 8135:1999, which have been technically revised.

ISO 6020 consists of the following parts, under the general title *Hydraulic fluid power — Mounting dimensions for single rod cylinders, 16 MPa (160 bar) series*:

- *Part 1: Medium series*
- *Part 2: Compact series*
- *Part 3: Compact series with bores from 250 mm to 500 mm*

Introduction

In hydraulic fluid power systems, power is transmitted and controlled through a liquid under pressure within an enclosed circuit.

One component of such systems is the fluid power cylinder. This is a device that converts power into linear mechanical force and motion. It consists of a movable element, i.e. a piston and piston rod, operating within a cylindrical bore.

Hydraulic fluid power — Mounting dimensions for single rod cylinders, 16 MPa (160 bar) series —

Part 1: Medium series

1 Scope

This part of ISO 6020 establishes metric mounting dimensions for medium series cylinders, 16 MPa [160 bar ¹⁾], as required for interchangeability of commonly used hydraulic cylinders.

The medium series dimensions are applicable to round head cylinders with bores from 25 mm to 200 mm and to both round and square head cylinders with bores larger than 200 mm, thus allowing a wider range of applications.

NOTE This part of ISO 6020 allows manufacturers of hydraulic equipment flexibility in the design of 16 MPa (160 bar) cylinders and does not restrict technical development; however, it does provide basic guidelines.

2 Normative references

The following referenced documents are indispensable for the application of this document. For dated references, only the edition cited applies. For undated references, the latest edition of the referenced document (including any amendments) applies.

ISO 1179-1, *Connections for general use and fluid power — Ports and stud ends with ISO 228-1 threads with elastomeric or metal-to-metal sealing — Part 1: Threaded ports*

ISO 3320:1987, *Fluid power systems and components — Cylinder bores and pistons rod diameters — Metric series*

ISO 4395, *Fluid power systems and components — Cylinders — Piston rod thread dimensions and types*

ISO 5598, *Fluid power systems and components — Vocabulary*

ISO 6099:2001, *Fluid power systems and components — Cylinders — Identification code for mounting dimensions and mounting types*

ISO 6149-1, *Connections for hydraulic fluid power and general use — Ports and stud ends with ISO 261 metric threads and O-ring sealing — Part 1: Ports with truncated housing for O-ring seal*

ISO 6162-1, *Hydraulic fluid power — Flange connectors with split or one-piece flange clamps and metric or inch screws — Part 1: Flange connectors for use at pressures of 3,5 MPa (35 bar) to 35 MPa (350 bar), DN 13 to DN 127*

ISO 6162-2, *Hydraulic fluid power — Flange connectors with split or one-piece flange clamps and metric or inch screws — Part 2: Flange connectors for use at pressures of 35 MPa (350 bar) to 40 MPa (400 bar), DN 13 to DN 51*

1) 1 bar = 0,1 MPa = 10⁵ Pa; 1 MPa = 1 N/mm².

ISO 6164, *Hydraulic fluid power — Four-screw, one-piece square-flange connections for use at pressures of 25 MPa and 40 MPa (250 bar and 400 bar)*

ISO 8132, *Hydraulic fluid power — Single rod cylinders, 16 MPa (160 bar) medium and 25 MPa (250 bar) series — Mounting dimensions for accessories*

3 Terms and definitions

For the purposes of this document, the terms and definitions given in ISO 5598 apply.

4 Dimensions

4.1 The mounting dimensions for cylinders manufactured in accordance with this part of ISO 6020 shall be selected from Figures 1 to 6 and Tables 1 to 6 inclusive.

4.2 The dimensions for ports and flanges shall be selected from Table 7 and the relevant International Standards cited therein.

4.3 All dimensions and mounting types in this part of ISO 6020 are labelled with codes in accordance with ISO 6099.

5 Bore sizes

This part of ISO 6020 covers the following bore sizes, expressed in millimetres, in accordance with ISO 3320:1987, Table 1:

25 — 32 — 40 — 50 — 63 — 80 — 100 — 125 — 160 — 200 — 250 — 320 — 400 — 500

6 Stroke tolerances

Tolerances on stroke shall be in accordance with Table 9.

7 Mounting types

This part of ISO 6020 includes the following mounting types, identified in accordance with ISO 6099:2001, Table 2:

- a) MF 1 — Head, rectangular flange;
- b) MF 2 — Cap, rectangular flange;
- c) MF 3 — Head, circular flange;
- d) MF 4 — Cap, circular flange;
- e) MP 3 — Cap, fixed plain eye;
- f) MP 4 — Cap, detachable plain eye;
- g) MP 5 — Cap, fixed eye with spherical bearing;
- h) MP 6 — Cap, detachable eye with spherical bearing;
- i) MS 2 — Side lugs;
- j) MT 4 — Intermediate fixed or movable trunnion (male).

8 Piston rod characteristics

8.1 This part of ISO 6020 covers piston rods that have a shouldered male thread end; see Figure 1 and Table 1 for basic dimensions.

8.2 For rod end types, see ISO 4395.

8.3 Accessory mounting dimensions shall be selected in accordance with ISO 8132.

9 Identification statement (reference to this part of ISO 6020)

It is strongly recommended to manufacturers who have chosen to conform to this part of ISO 6020 that the following statement be used in test reports, catalogues and sales literature:

“Medium series hydraulic single rod cylinders for use at 16 MPa (160 bar) have been selected in accordance with ISO 6020-1:2007, *Hydraulic fluid power — Mounting dimensions for single rod cylinders, 16 MPa (160 bar) series — Part 1: Medium series.*”

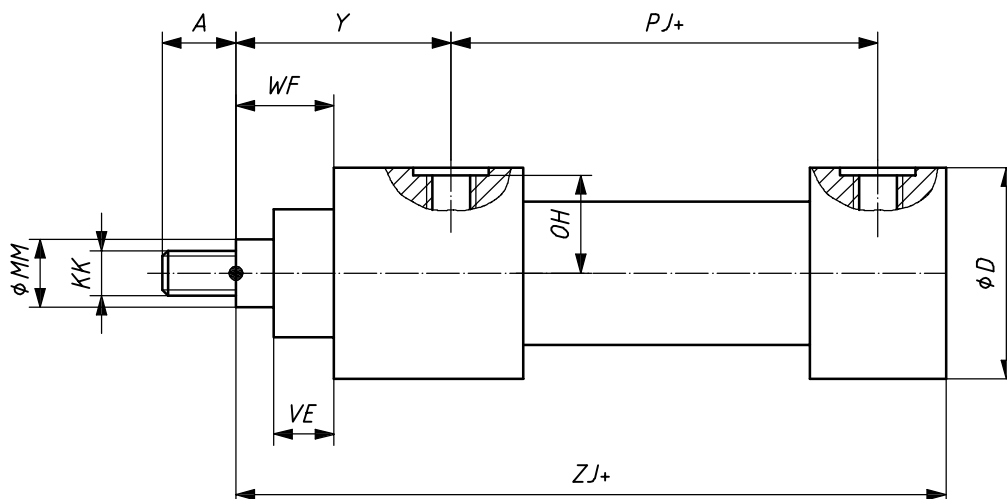

NOTE Rod end types are controlled by ISO 4395.

Figure 1 — General dimensions

Table 1 — General dimensions

Dimensions in millimetres

Bore	Rod MM	ZJ ^a	KK 6g	A max.	Y ^a	PJ ^a	D max.	OH ^b	VE max.	WF ^a
25	14	150	M12 × 1,25	16	58	77	56	25,5	15	28
	18		M12 × 1,25	16						
			M14 × 1,5	18						
32	18	170	M14 × 1,5	18	64	89	67	30	19	32
	22		M14 × 1,5	18						
			M16 × 1,5	22						
40	22	190	M16 × 1,5	22	71	97	78	35	19	32
	28		M16 × 1,5	22						
			M20 × 1,5	28						
50	28	205	M20 × 1,5	28	72	111	95	44	24	38
	36		M20 × 1,5	28						
			M27 × 2	36						
63	36	224	M27 × 2	36	82	117	116	54	29	45
	45		M27 × 2	36						
			M33 × 2	45						
80	45	250	M33 × 2	45	91	134	130	62	36	54
	56		M33 × 2	45						
			M42 × 2	56						
100	56	300	M42 × 2	56	108	162	158	75	37	57
	70		M42 × 2	56						
			M48 × 2	63						
125	70	325	M48 × 2	63	121	174	192	92	37	60
	90		M48 × 2	63						
			M64 × 3	85						
160	90	370	M64 × 3	85	143	191	238	115	41	66
	110		M64 × 3	85						
			M80 × 3	95						
200	110	450	M80 × 3	95	190	224	285	138	45	75
	140		M80 × 3	95						
			M100 × 3	112						
250	140	550	M100 × 3	112	—	—	365	—	64	96
	180		M100 × 3	112						
			M125 × 4	125						
320	180	660	M125 × 4	125	—	—	455	—	71	108
	220		M125 × 4	125						
			M160 × 4	160						
400	220	740	M160 × 4	160	—	—	565	—	90	130
	280		M160 × 4	160						
			M200 × 4	200						
500	280	890	M200 × 4	200	—	—	645	—	110	163
	360		M200 × 4	200						
			M250 × 6	250						

NOTE If other piston rod diameters or other threads are required, use those identified in ISO 3320 and ISO 4395.

^a Tolerances for dimensions ZJ, WF, Y and PJ are dependent on stroke; see Table 8.^b Dimension OH is optional and only pertains to threaded ports.

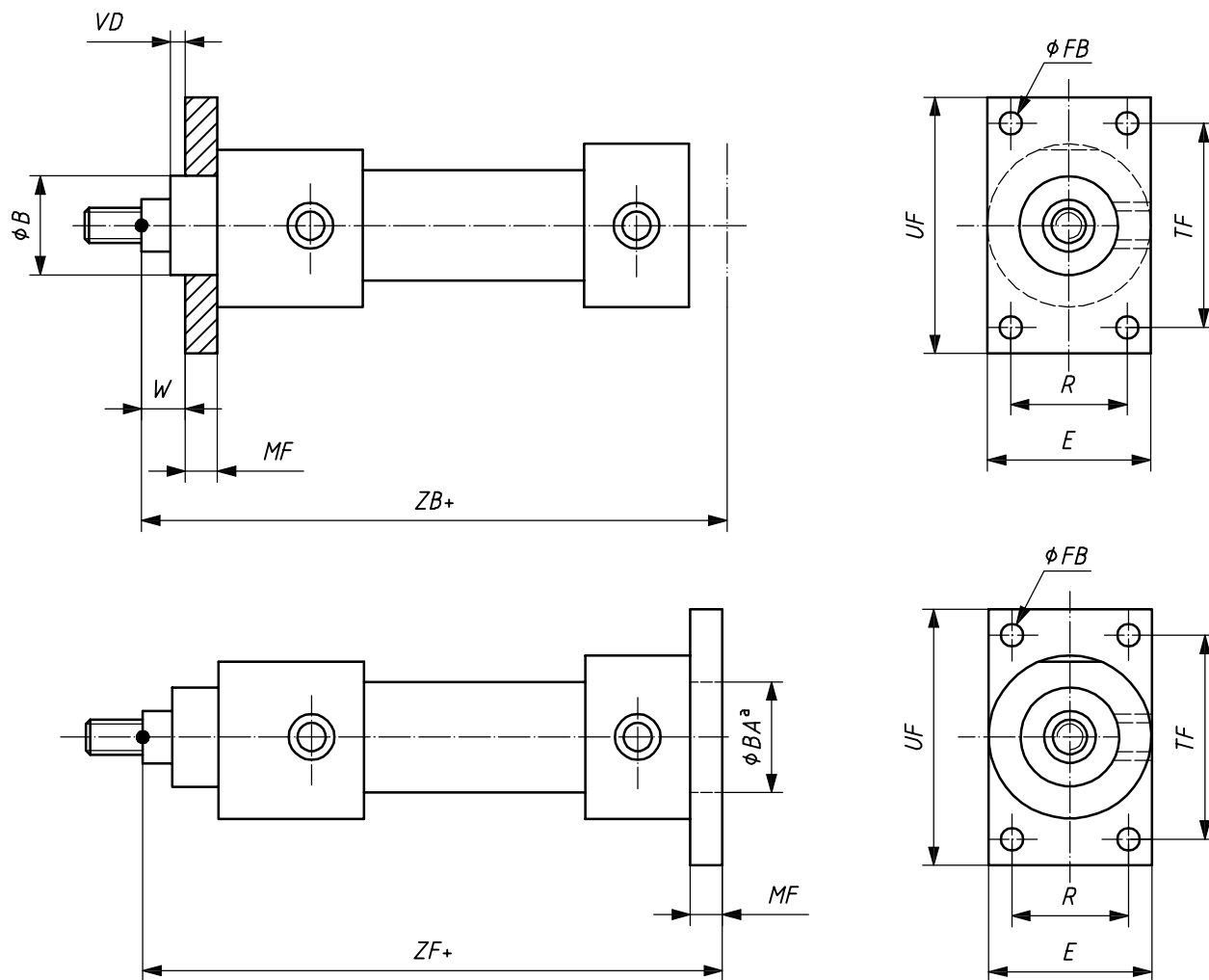

^a Optional.

Figure 2 — MF 1 — Head, rectangular flange and MF 2 — Cap, rectangular flange

Table 2 — Dimensions of rectangular flange mounting types MF 1 and MF 2

Dimensions in millimetres

Bore	<i>FB</i> H13	<i>TF</i> js13	<i>R</i> js13	<i>VD</i> min.	<i>W</i> ^a	<i>ZF</i> ^a	<i>ZB</i> max.	<i>BA, B</i> H8/f8	<i>UF</i> max.	<i>E</i> max.	<i>MF</i> js13
25	6,6	69,2	28,7	3	16	162	158	32	85	60	12
32	9	85	35,2	3	16	186	178	40	105	70	16
40	9	98	40,6	3	16	206	198	50	115	80	16
50	11	116,4	48,2	4	18	225	213	60	140	100	20
63	13,5	134	55,5	4	20	249	234	70	160	120	25
80	17,5	152,5	63,1	4	22	282	260	85	185	135	32
100	22	184,8	76,5	5	25	332	310	106	225	160	32
125	22	217,1	90,2	5	28	357	335	132	255	195	32

^a Tolerances for dimensions *W* and *ZF* are dependent on stroke; see Table 8.

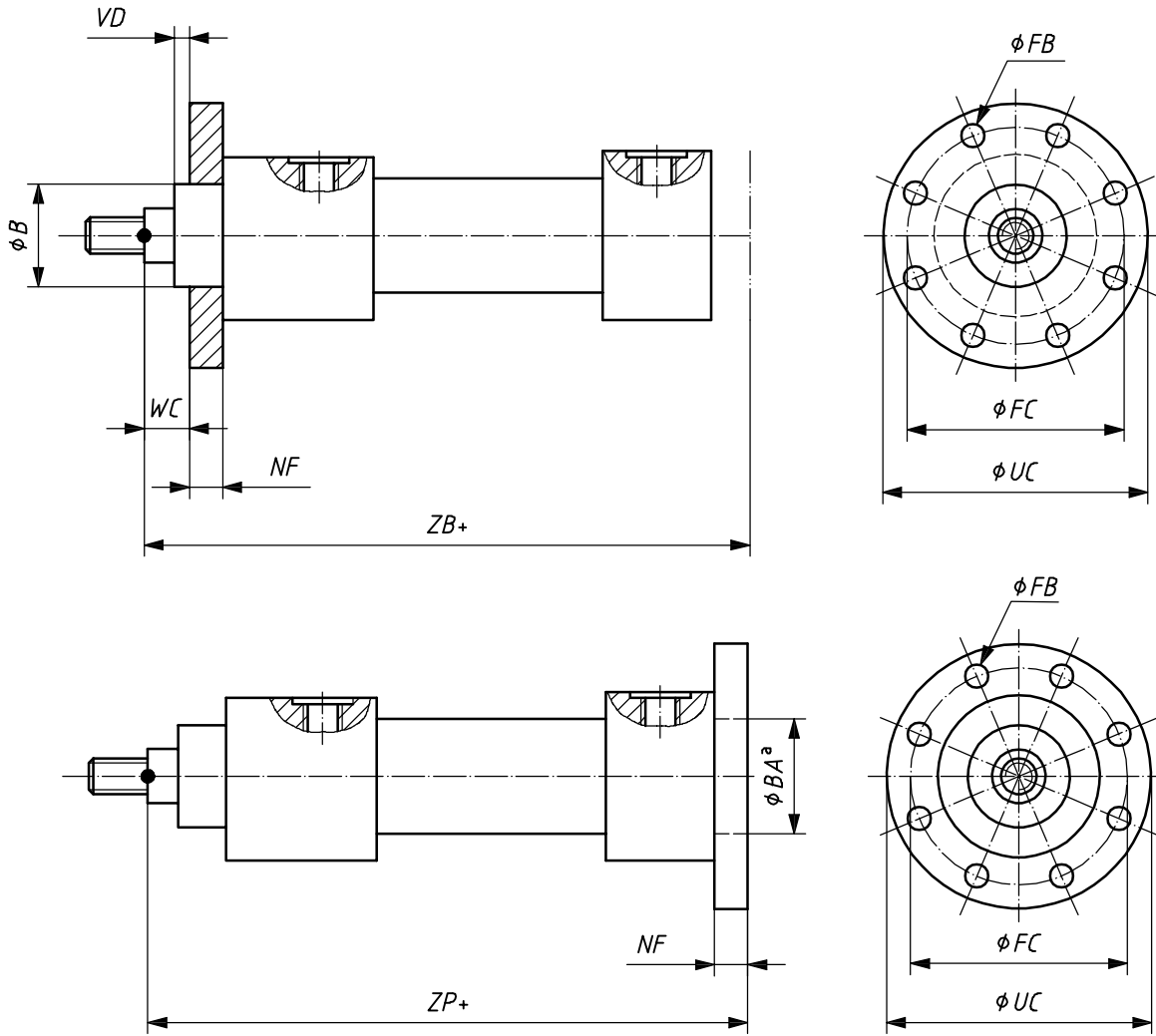

a Optional.

Figure 3 — MF 3 — Head, circular flange and MF 4 — Cap, circular flange

Table 3 — Dimensions of circular flange mounting types MF 3 and MF 4

Dimensions in millimetres

Bore	FB H13	FC js13	VD min.	WC ^a	ZP ^a	ZB max.	BA, B H8/f8	UC max.	NF js13
25	8 × Ø6,6	75	3	16	162	158	32	90	12
32	8 × Ø9	92	3	16	186	178	40	110	16
40	8 × Ø9	106	3	16	206	198	50	125	16
50	8 × Ø11	126	4	18	225	213	60	150	20
63	8 × Ø13,5	145	4	20	249	234	70	170	25
80	8 × Ø17,5	165	4	22	282	260	85	195	32
100	8 × Ø22	200	5	25	332	310	106	240	32
125	8 × Ø22	235	5	28	357	335	132	275	32
160	8 × Ø22	280	5	30	406	380	160	320	36
200	8 × Ø26	340	5	35	490	480	200	385	40
250	8 × Ø33	420	8	40	606	580	250	490	56
320	8 × Ø39	520	8	45	723	710	320	600	63
400	8 × Ø45	640	10	50	820	790	400	730	80
500	12 × Ø45	720	10	63	990	940	500	810	100

^a Tolerances for dimensions WC and ZP are dependent on stroke; see Table 8.

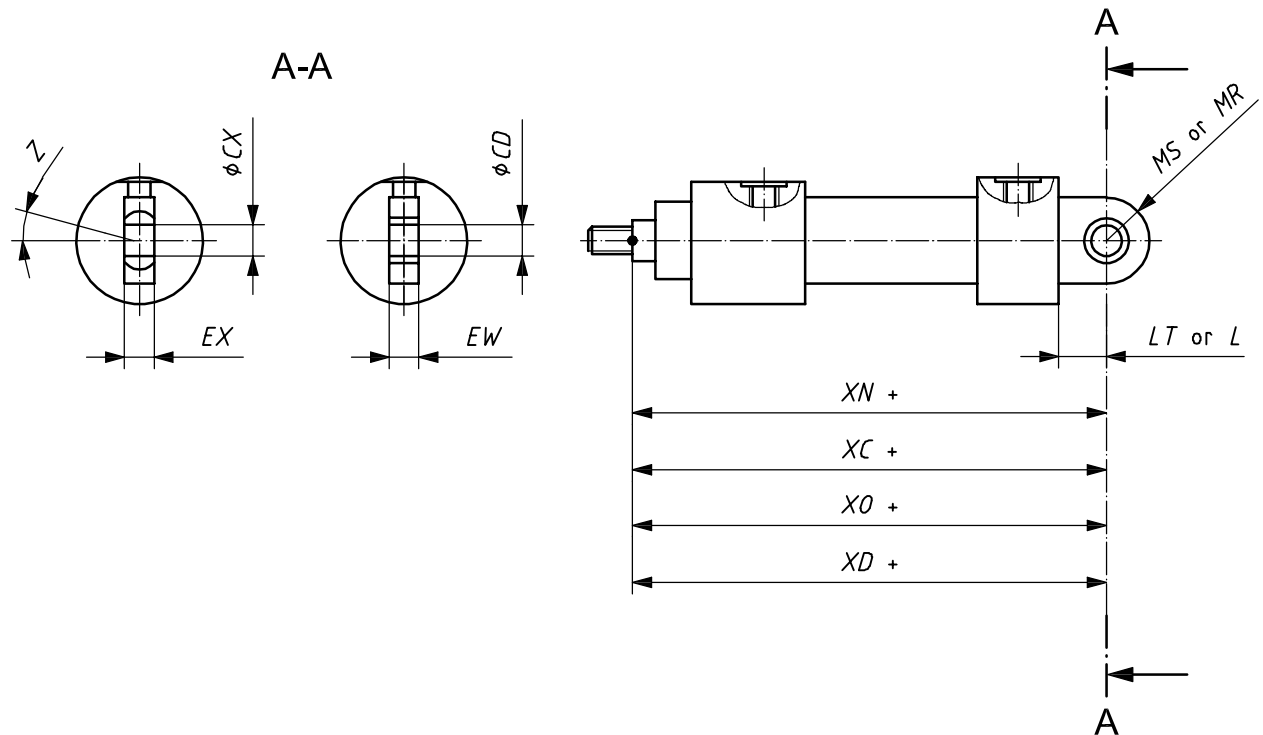

Figure 4 — MP 3 — Cap, fixed plain eye, MP 4 — Cap, detachable plain eye, MP 5 — Cap, fixed eye with spherical bearing, MP 6 — Cap, detachable eye with spherical bearing

Table 4 — Dimensions of cap eye mountings MP 3, MP 4, MP 5 and MP 6

Dimensions in millimetres

Bore	CD^b	CX^c	EW^b or EX^c	L^b or LT^c	MR^b or MS^c	XC, XD, XO or $XN^{a, d}$	Tilting angle Z min.
	H9	H7	h12	min.	max.		
25	12	12	12	16	16	178	4°
32	16	16	16	20	20	206	4°
40	20	20	20	25	25	231	4°
50	25	25	25	32	32	257	4°
63	32	32	32	40	40	289	4°
80	40	40	40	50	50	332	4°
100	50	50	50	63	63	395	4°
125	63	63	63	71	71	428	4°
160	80	80	80	90	90	505	4°
200	100	100	100	112	112	615	4°
250	125	125	125	160	160	773	4°
320	160	160	160	200	200	930	4°
400	200	200	200	250	250	990	4°
500	250	250	250	320	320	1210	4°

^a Tolerances for dimensions XC, XD, XO and XN are dependent on stroke; see Table 8.
^b The dimensions CD, EW, L and MR are valid for mounting types MP 3 and MP 4.
^c The dimensions CX, EX, LT and MS are valid for mounting types MP 5 and MP 6.
^d The dimension XC is valid for mounting type MP 3, the dimension XD is valid for mounting type MP 4, the dimension XO and XC are valid for mounting type MP 5, and the dimension XN is valid for mounting type MP 6.

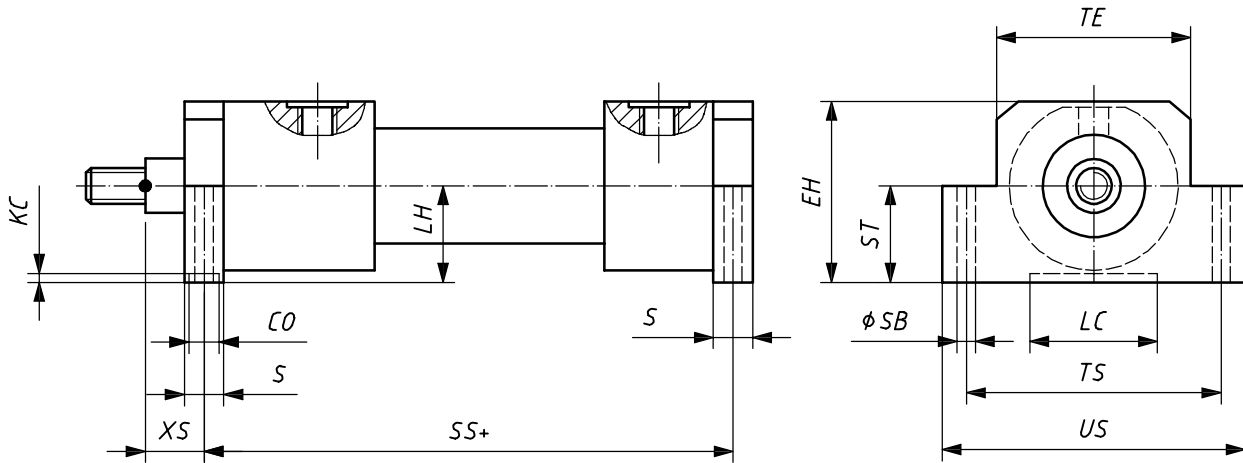

Figure 5 — MS 2 — Side lugs

Table 5 — Dimensions of side lugs mounting MS 2

Dimensions in millimetres

Bore	<i>S</i> js13	<i>XS</i> ^a	<i>SS</i> ^a	<i>TE</i> js13	<i>TS</i> js13	<i>US</i> max.	<i>SB</i> H13	<i>EH</i> max.	<i>LH</i> h10	<i>ST</i> max.	<i>KC</i> ^b min.	<i>CO</i> ^b N9	<i>LC</i> ^{b, c} min.
25	20	18	142	56	75	92	9	60	32	32	3,5	6	12
32	25	19,5	163	67	90	110	11	72	38	38	4	8	17
40	25	19,5	183	78	100	120	11	82	43	43	4	8	17
50	32	22	199	95	120	145	14	100	52	52	4,5	10	20
63	32	29	211	116	150	180	18	120	62	62	4,5	10	20
80	40	34	236	130	170	210	22	135	70	70	5	14	28
100	50	32	293	158	205	250	26	161	82	82	6	16	34
125	56	32	321	192	245	300	33	196	100	100	6	18	37
160	60	36	364	238	295	350	33	238	119	119	8	22	78
200	72	39	447	285	350	415	39	288	145	145	9	28	122

^a Tolerances for dimensions *XS* and *SS* are dependent on stroke; see Table 8.

^b Keyway is optional.

^c Minimum effective length of the keyway.

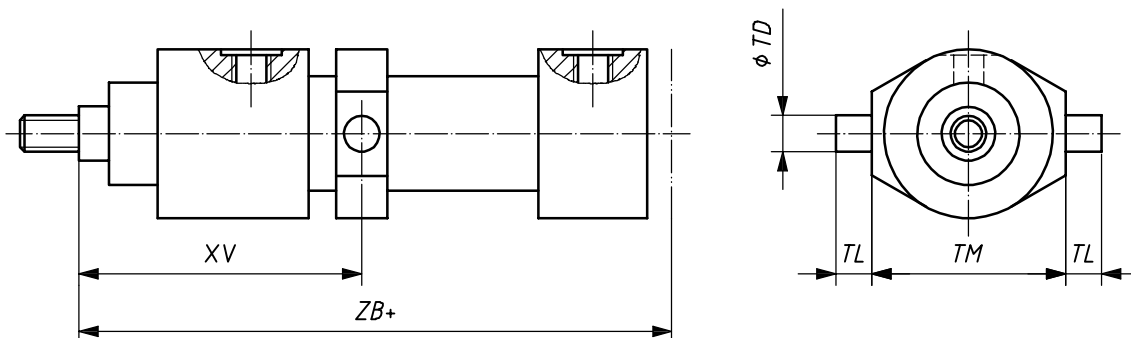

Figure 6 — MT 4 — Intermediate fixed or movable trunnion (male)

Table 6 — Dimensions of intermediate male trunnion mounting MT 4

Dimensions in millimetres

Bore	<i>TD</i> f8	<i>TL</i> js13	<i>TM</i> h12	<i>XV</i> ^a	<i>ZB</i> max.
25	12	10	63	variable; users should consult the manufacturer for minimum and maximum values	158
32	16	12	75		178
40	20	16	90		198
50	25	20	105		213
63	32	25	120		234
80	40	32	135		260
100	50	40	160		310
125	63	50	195		335
160	80	63	240		380
200	100	80	295		480
250	125	100	370		580
320	160	125	470		710
400	200	160	570		790
500	250	250	700		940

^a Tolerances for dimension *XV* are dependent on stroke; see Table 8.

Table 7 — Port and flange sizes

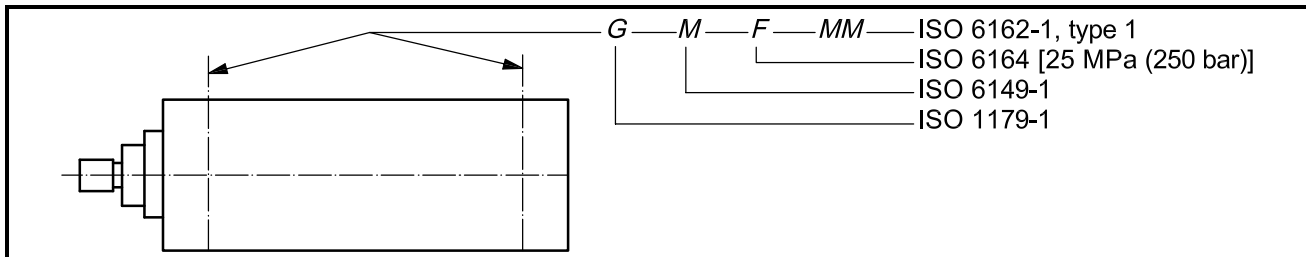

Bore	Port ISO 1179-1		Port ISO 6149-1		Square flange ISO 6164				Rectangular flange ISO 6162-1				
	G		M		F				MM				
	EE	EC	EE	EC	Nominal flange size ^b DN	FF	EA	ED	Nominal flange size ^b DN	FF	EA	EB	ED
	6g	ref. ^a	6g	ref. ^a		0 -1,5	± 0,25	6g		0 -1,5	± 0,25	± 0,25	6g
25	G 1/4	7,5	M14 × 1,5	7,5	—	—	—	—	—	—	—	—	—
32	G 3/8	9	M18 × 1,5	11	—	—	—	—	—	—	—	—	—
40 50	G 1/2	14	M22 × 1,5	14	—	—	—	—	—	—	—	—	—
63 80	G 3/4	18	M27 × 2	18	13	15	29,7	M8	13	12,7	17,5	38,1	M8
100 125	G 1	23	M33 × 2	23	19	20	35,4	M8	19	19,1	22,3	47,6	M10
160 200	G 1 1/4	30	M42 × 2	30	25	25	43,8	M10	25	25,4	26,2	52,4	M10
250 320	G 1 1/2	32	M48 × 2	36	32	32	51,6	M12	32	31,8	30,2	58,7	M10
400 500	—	—	M60 × 2	44	38	38	60,1	M16	38	38,1	35,7	69,9	M12

CAUTION — When selecting the largest diameter piston rod in a given bore size in connection with hydraulic systems where pull loads and/or pressure intensification effects can be generated, the pressure in the piston rod cavity of the cylinder can be two or more times the working pressure of the hydraulic system. In these cases, flange ports in accordance with ISO 6162-1 or ISO 6164, as shown in this table, might not have sufficient pressure ratings. When flange ports with a higher pressure rating are needed, they may be selected from the higher pressure series in ISO 6162-2 and ISO 6164.

^a For reference only. Connecting hole application can require a different size.

^b Depending on the cylinder mounting type (for example, MF 4), possible interference between the mounting flange screws and the port flange shall be checked.

Table 8 — Tolerances for mounting dimensions that are dependent on stroke

Dimensions in millimetres

Code for mounting dimension	<i>ZJ</i> ^a	<i>WF</i>	<i>WC</i>	<i>ZP</i> or <i>ZF</i> ^a	<i>XC, XD, XO</i> or <i>XN</i> ^a	<i>XV</i>	<i>ZB</i> ^a	<i>W</i>	<i>XS</i>	<i>SS</i> ^a	<i>Y</i>	<i>PJ</i> ^a
Nominal stroke	Tolerances											
≤ 1 250	± 1,5	± 2	± 2	± 1,5	± 1,5	± 2	max.	± 2	± 2	± 1,5	± 2	± 1,5
> 1 250 ≤ 3 150	± 3	± 4	± 4	± 3	± 3	± 4		± 4	± 4	± 3	± 4	± 3
> 3 150 ≤ 8 000	± 5	± 8	± 8	± 5	± 5	± 8		± 8	± 8	± 5	± 8	± 5
^a Length including stroke. Stroke tolerances from Table 9 shall not be added to the tolerances in this table.												

Table 9 — Tolerances on piston strokes

Dimensions in millimetres

Nominal stroke	Tolerance
≤ 1 250	+2 0
> 1 250 ≤ 3 150	+5 0
> 3 150 ≤ 8 000	+8 0

Bibliography

- [1] ISO 273, *Fasteners — Clearance holes for bolts and screws*
- [2] ISO 4393, *Fluid power systems and components — Cylinders — Basic series of piston strokes*

