

STUDY OF INDUSTRIAL HYDRAULIC ACCESSORIES

Q.S. Khan



TANVEER PUBLICATIONS

Hydro Electric Machinery Primises
A/12, Ram-Rahim Udyog Nagar, LBS Marg, Sonapur,
Bhandup (W), Mumbai - 400078

INDEX

Sr.No	COMPONENTS	PAGE NO.
A - ACCESSORIES FOR BETTER FUNCTIONING OF POWER PACK UNIT		
1)	Reservoir	04
2)	Oil level indicator and controller	10
3)	Suction stainer	11
4)	Return line filter	12
5)	Pressure line filter	14
6)	Filler breather assembly	15
7)	Bell housing	16
8)	Extension bracket assembly	17
9)	Coupling	18
10)	Pressure gauge	19
11)	Pressure gauge isolator	21
12)	Pressure gauge dampner	22
13)	Heat exchanger	23
14)	Water-cooler	24
15)	Chiller	25
16)	Cooling Tower	26
17)	Heater	27
18)	Fluid level indicator and controller	28
19)	Flow meter and indicator	29
20)	Temperature indicator and controller	31
21)	Magnetic seperator	32
22)	Pipe clamp	33
23)	Diagnostic couplers	34
24)	Diffusars	35
25)	Hydraulic fuse	36
26)	Flexible Separator	37
B - ACCESSORIES FOR BETTER FUNCTIONING OF HYDRAULIC MACHINE		
27)	Oil cleaning unit	39
28)	Hose breack valve	41
29)	Quick connection coupling	42
30)	Rotary Joints	44
31)	Anti-vibration unit	45
32)	Anchor bolt	46
33)	Cable drag chain	47
34)	Hand pump	48
35)	Lubrication system	49
36)	Rod end bearing	51
37)	Flow divider (Tendum gear pump type)	52
C - ELECTRICAL ACCESSORIES		
38)	Pressure switch	54
39)	Photo-electric switches	55
40)	Limit switches	56
41)	Pendent switch	57
42)	Proximity switch	58
43)	Foot operated switches	69
44)	Pressure Transducer and transmitter	60
45)	DRO	62
46)	LVDT	63
47)	Potentio-meter	64
48)	Load cell	66
49)	PLC	67
50)	NC / CNC	69
51)	Thermo Switches	70

Section-A
ACCESSORIES
FOR BETTER
FUNCTIONING OF
POWER PACK UNIT

5.1 Reservoir

Reservoir or hydraulic fluid tank or oil tank is used to store the working fluid. The quality and condition of working fluid is most important for satisfactory operation of system. Hence reservoir is designed, made and assembled with all necessary accessories to keep working fluid in best operating condition.

A reservoir serves following functions: -

- 1) To store sufficient quantity of working fluid.
- 2) To dissipate heat of fluid.
- 3) With the help of accessories it keeps fluid in best operating condition.

5.1.1 Design criteria of Reservoir: -

- a) The reservoir is generally made rectangular in shape as it has more surface area to dissipate heat than cylindrical reservoir.
- b) When cylinder takes forward stroke, more oil is pumped out in hydraulic cylinder as compared to what reservoir receives from the return port of the cylinder. And when cylinder takes return stroke, then reservoir receives more oil as compared to it pumps oil in cylinder. This is due to difference in cross-sectional area of cylinder in two sides of piston. Hence oil level in reservoir always varies. A reservoir should have sufficient extra space to accommodate excess fluid being collected from system, while in operation as well as at the time of maintenance.

The size and volume of reservoir is designed in such a way that there is always sufficient oil above suction filter, otherwise it will create (vortex) whirlpool near suction line of pump, which will cause suction of air and cause cavitations.

- c) A 5 square ft. area of reservoir dissipates heat equivalent to 0.25HP. Hence if oil cooler is not being used, then surface area of reservoir should be sufficient enough to dissipate heat equivalent to 20% of HP of electric motor used in system. (Assuming 80% efficiency of system, and 20% energy getting converted into heat).
- d) Due to wear and tear metallic particles of valve, pump, cylinder, and elastomeric particle of seal, guide-ring etc. return to reservoir. If they do not get time for settlement and air-bubble do not get time for aeration in tank, then they may again get sucked in pump and increase the wear and tear of system. Hence volume of fluid in reservoir should be such that these particles should get at least two to three minute times for settlement. Hence reservoir capacity should be more than 3 times the pump discharge capacity. More the capacity of reservoir, fluid will get more time for heat dissipation, aeration and settlement of particles of contamination.
- e) Reservoir should avoid contamination of working fluid from air-dust, mixing of water and oil from outside sources. Reservoir should have facility to fill oil with proper filter, drain out oil for cleaning and maintenance, and should have means to see oil level all the time.

5.1.2 To fulfill above mentioned requirement reservoir is fitted with following accessories: -

- a) "Filler-breather assembly." It provides oil-filling opening with oil filter, and filter for air, which is sucked in tank and exhausted.
- b) Return line filter, to filter oil returning in tank from system.
- c) Suction filter, to filter oil sucked by pump.
- d) Oil level indicator to indicate oil level in tank.

- e) Temperature indicator, to indicate temperature of oil in reservoir.
- f) Drain plug to drain out oil when required.
- g) Hooks for lifting of whole reservoir with its accessories.
- h) If reservoir is of pressurized type then accommodating air-relief valve, vacuum valve etc. to regulate air pressure in tank.
- i) Inlet oil port for filling oil from external oil filtering cum filling machine.
- j) Inspection and cleaning windows are provided to check, clean and do servicing of component mounted in-side tank.
- k) Baffles to control the direction of flow of oil inside tank.
- l) Diffuser to reduce the flow velocity of oil returning to tank.

The accessories mentioned above and many more will be discussed in this chapter.

5.1.3 Types of reservoir: -

There are two types of reservoir.

- 1) **Integral reservoir.**
- 2) **Separate reservoir**

Integral type of reservoir are those reservoirs which are build inside the machine-body. For example base of machine, or bottom or top platen of hydraulic press could be made fluid tight and hydraulic oil could be stored in it. This type of design requires minimum space, good esthetic looks, but some time servicing and maintenance of system become difficult. Oil heating also produces thermal stress and distortion in machine body. Hence this type of design is rarely used.

Separate type of reservoir is most commonly used in industry. Generally they are rectangular in shape and designed in many ways for convenience.

Dual purpose reservoir is also a type of reservoir in which reservoir is used for more than one purpose. For example in tractor, Transmission case is used for storing hydraulic oil, along with housing Transmission gear assembling. But there are only few examples of such reservoir in industry..

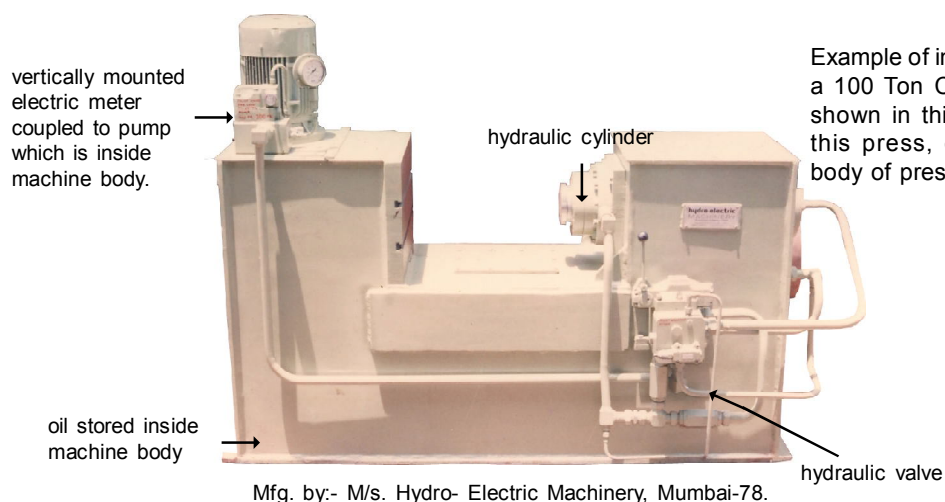

Types of Separate Reservoir:-

Separate types of reservoirs are constructed in three ways.

a) Tank top Assembly type Reservoir: -

This is a rectangular tank. Width of tank is almost equal to height of tank, and length is approximately double the width. Special feature of this type is, motor, pump, manifold block and most of the hydraulic valves and accessories are mounted on top cover of reservoir.

Main advantage of this type of reservoir is its compactness. Disadvantage of this type is that when oil immersed type of pump is used with bell-housing and vertical motor, than for any servicing of pump, oil of tank is to be drained out. And if tank is of large capacity such as 500 to 1000 liters then storing such large amount of oil in another container is very difficult. One of the way by which this problem is solved, is by making top cover from thick steel plate, and for any servicing complete top cover is lifted along with motor, pump assembly mounted on it by over-head crane, and after completing servicing and maintenance, tank top cover is again placed on it's original position.

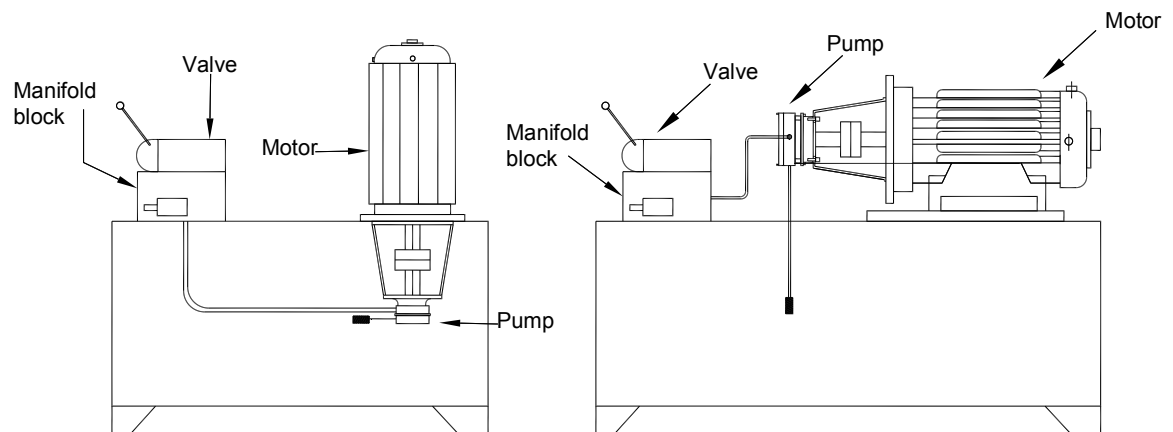

Tank top assembly type reservoir

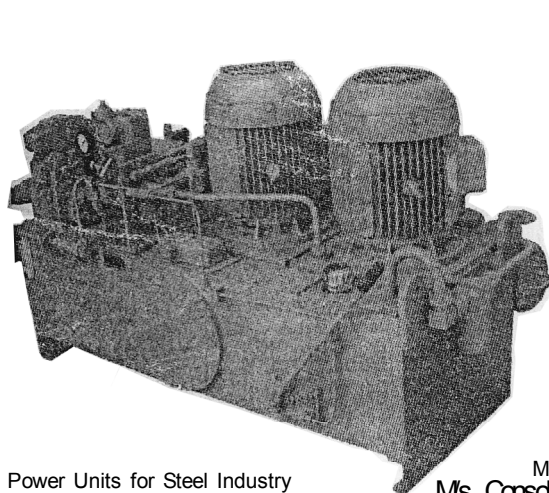

Power Units for Steel Industry

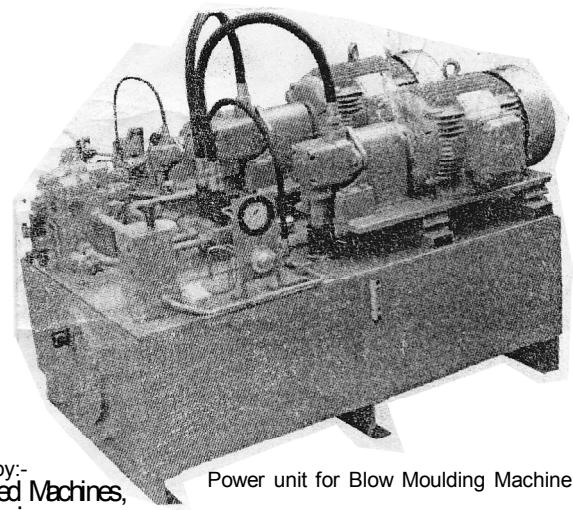

Power unit for Blow Moulding Machine

Mfg. by:-
Ms. Consolidated Machines,
Mumbai.

b) L-shape reservoir: -

This type of construction consists of a large base frame. On some part of base frame reservoir is mounted and on remaining part of base frame motor, pump manifold and other assemblies are mounted.

Advantage of this type is that pump will always get supply of fluid, as fluid level will be above pump height. Disadvantage of this type is that it occupies more space

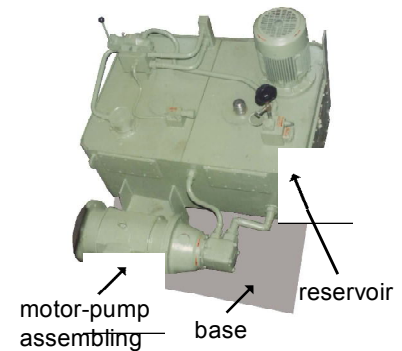
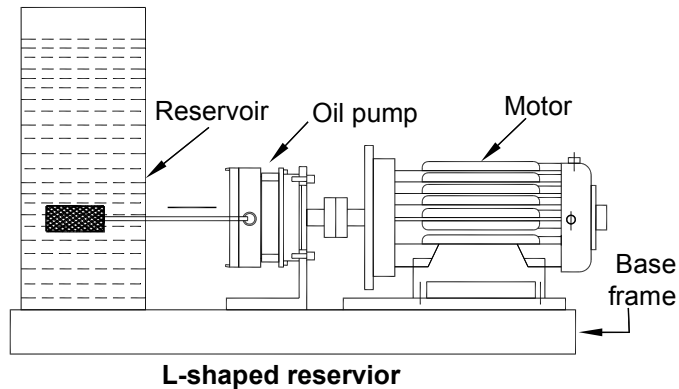
**Top view of L-shaped Reservoir**

Mfg. by:-
M/s. Hydro Electric Machineries,
Mumbai.

(c) Over-head reservoir: -

In this type of construction reservoir is mounted on a frame structure, and below reservoir motor, pump, manifold, valve, etc. are mounted.

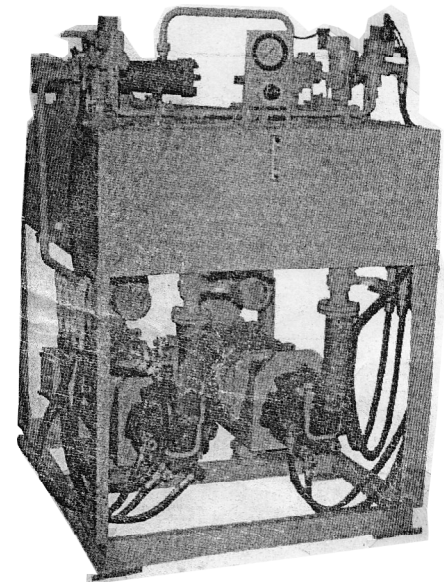
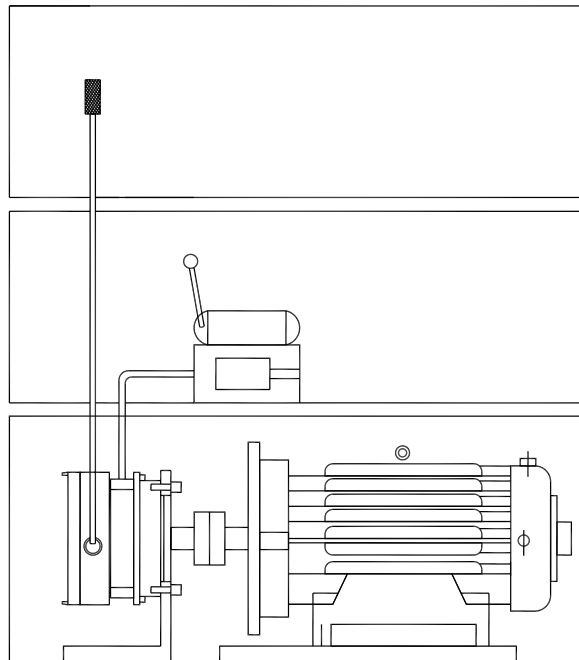

Over-head reservoir type of power unit

Mfg. by:-
M/s. Consolidated Machines, Mumbai.

5.1.4 Construction of reservoir: -

- 1) Reservoir is made from 3 to 10mm steel plate depending upon its capacity to store working fluid. It is also made from other material depending upon its use, such as aluminum reservoir is use in aircraft, S.S. reservoir is use in chemical industries etc.
- 2) As discussed earlier capacity is generally kept more than 3 to 5 times the pump discharge capacity. And if oil cooler is not to be use then surface area of reservoir should be able to dissipate all the heat generated.

3) Reservoir is also made larger than calculated volume, so that there should be at least 100mm air space above oil level, that is between tank-top cover and maximum fluid level. (In small tank, space could be 10% of total volume of tank).

This space is required for de-aeration of air, which will be released from oil. To compensate the increase in volume due to heating of oil. As well as to accommodate all the oil of the system, if they drained out from cylinder and other component and collected in reservoir.

4) Exhaust oil coming from cylinder and system brings metal, rubber particle, and air-bubbles. If they get sucked in pump immediately, then it will damage system due to metallic particle, and performance of system will be spongy and sluggish due to air-bubbles. Proper screen and baffles should be provided to avoid this. Following types of baffles are provided for better result.

a) **Wave-stream baffle configuration: -**

In wave-stream configuration, the heavy particle get settled in bottom, and light foam and particle float on surface, but both can not pass the baffle, and pump get some what clean fluid. But maximum travel of fluid is equal to length of reservoir. In case of circuit-stream baffle configuration, fluid travel doubles the length of reservoir. Hence fluid gets more surfaces for heat dissipation.

b) **Circuit –Stream Baffle Configuration: -**

5) Fluid returning to the system should be discharged below the surface of fluid. Preferably about 50 to 100mm. above the bottom of tank. Pipeline sucking the fluid from reservoir also should be much below the surface level of fluid. So that even in lowest fluid level condition sufficient fluid should be above suction point to avoid vortex or whirlpool which causes suction of air in pump. Both suction and exhaust pipe should be tapered at the end.

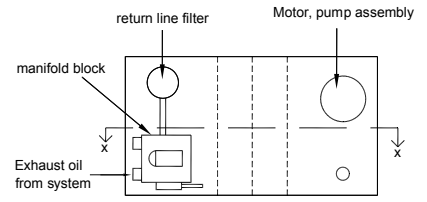

Top view of power unit with wave-system baffle configuration

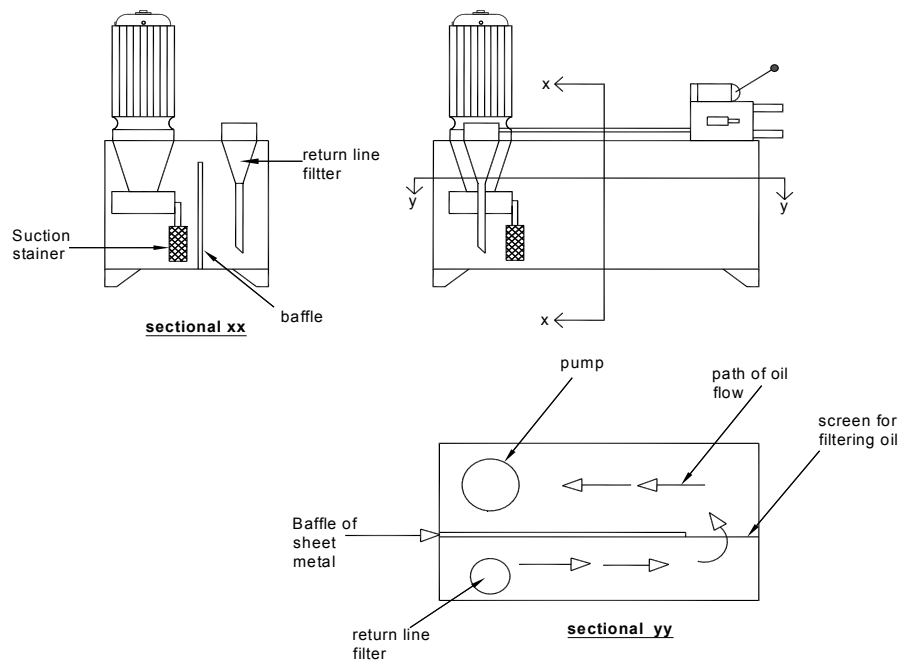
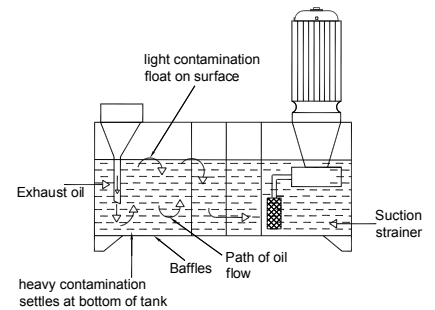

- 6) Top cover is bolted to reservoir; Motor, pump, manifold etc. are mounted on it. Care should be taken that through no joint either water or air can get into the reservoir. It should be absolutely sealed by using gasket and washer etc. Otherwise if air directly gets sucked-in, then dust will enter in reservoir. Or if any liquid or water leak in reservoir through top cover, then water and contaminated oil will get mixed with working fluid and will contaminate it. Hence care should be taken to seal reservoir completely.
- 7) Reservoir is fabricated from mild steel sheet metal. A deep corrosion may weaken the walls of reservoir. Hence special precaution should be taken to avoid rusting. Reservoir should be raised about 100 to 150mm, above ground. This avoid rusting of bottom of reservoir against wet ground, as well as help in cooling of oil due to free flow of air bellow tank. Outside surface of reservoir should be properly clean and painted with oil paint etc.
If mineral oil is used as working fluid, then it avoids rusting of inside surface of reservoir. But in case if reservoir is to be kept without using it for long time, then inside surface may start rusting due to moisture. In such case inside surface also should be cleaned, and applied with “mineral oil resistant paint” such as epoxy paint etc.
- 8) For changing fluid or for any-other purpose if fluid is to be removed from reservoir, then either it is to be pumped-out by external source, or drained-out from drain plug provided at bottom of reservoir. Fluid will drain-out completely along with all sedimentation of dust and contamination only if bottom of reservoir is made correctly. Botom of tank should be slightly tapered and drain plug should be provided at lower most position, so that all contamination gets removed along with fluid.

Access Cover:-

Access covers are provided at both ends of reservoir for convenience in servicing and maintenance of pump, filter and other components mounted inside tank. Access covers are of two type. Dished access cover and flat access cover.

Dished access cover is in form of a dish, fixed to reservoir with a single bolt mounted at centre, as explained in following diagram. While flat access cover is flat in shape, and fixed to reservoir with many bolts to avoid oil leakage.

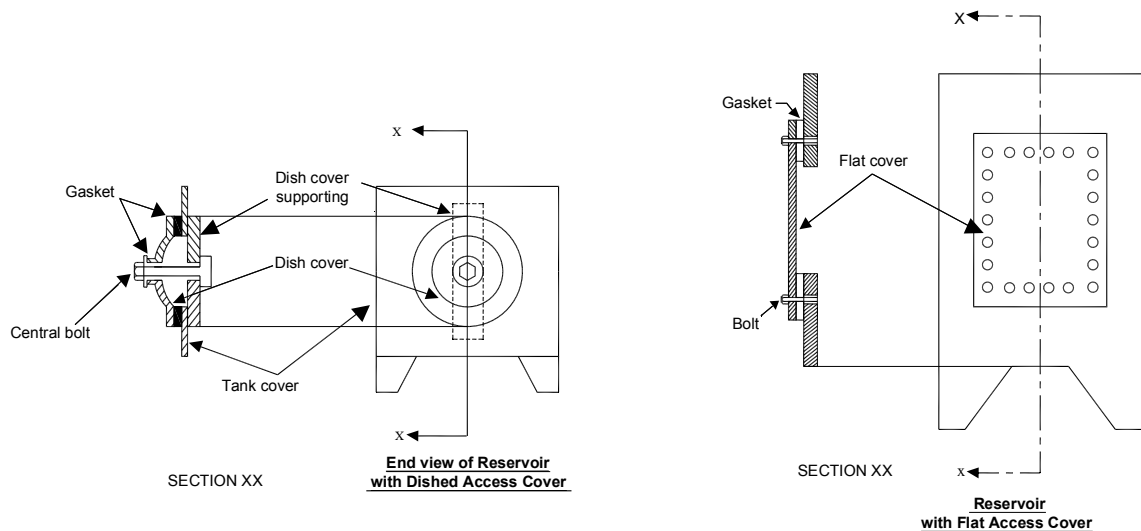

Websites of Manufacturers:

- www.consolidatedmachines.net
- www.hydraulicpresses.in

5.2 Oil Level Indicator

It is important to maintain the level of fluid in reservoir within minimum and maximum permissible limit. Because if level falls below permissible minimum level, then fluid may get heated up as it is small in quantity. Air will get less time to get released, contamination will get less time to get settled, and in worst case pump may get damaged due to dry running.

And when oil level rises above the maximum permissible level, then fluid may overflow from the tank when all fluid returns to reservoir. Nowadays vertical motor are used on tank top with bell housing and oil immersed pump. The coupling of motor pump should not be immersed in oil. High oil level cause continuous churning of oil, energy loss and heating. High fluid level also hampers the release of air from fluid, as there is no space between oil level and tank cover.

5.2.1 Type of Indicator: -

There are four types of level indicator, and they are used in industrial hydraulic power pack, as per the requirement of equipment.

- Tube type oil level indicator.
- Button type or window type oil level indicator.
- Dip stick.
- Electronic read-out.

Tube type has advantage that all the level within its range could be check, while window type can indicate very limited change in fluid level. Hence if window type is used then two such indicators should be used. One for minimum and other for maximum level. In industry tube type indicator available in many sizes, out of which 3inch and 5inch distance between mounting bolts are widely used. Window sizes are available in many sizes. As window types are mounted with BSP thread, hence they are available from 1/4, to 1 1/4" BSP thread sizes.

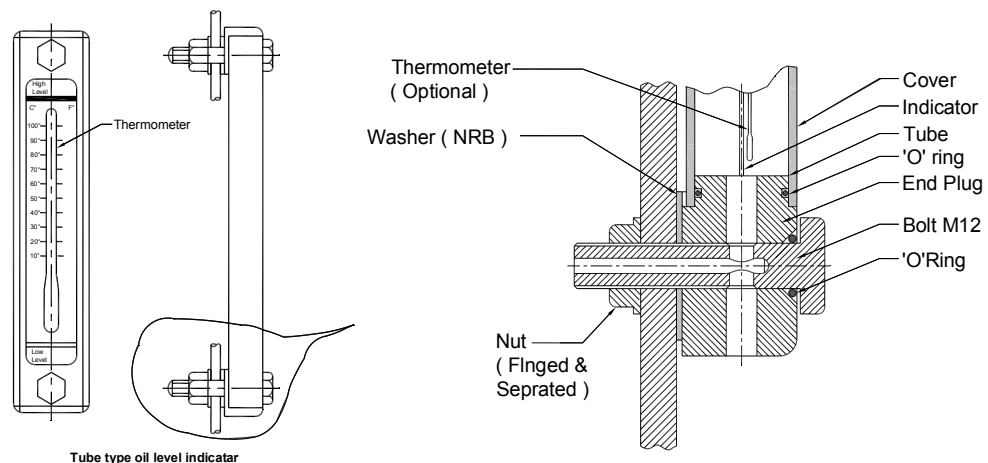
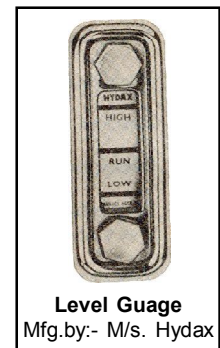

Some time a thermometer is also fixed in tube type oil-level indicator to check the temperature of fluid. As in no condition temperature of fluid should exceed 70° C.

Tube type oil level indicator consist of two bolts with hole at centre, a tube, a housing, and oil sealing arrangement. When oil level indicator bolted to reservoir, the oil enters in

Websites of Manufacturers:

- 1) www.hydaXindia.com
- 2) www.hydroline.com

5.3 Suction Strainer

There are always possibility of small as well as large contamination in fluid. Hence a filter always should be provided on suction side of a pump. A coarse filter, which is provided at suction side of pump is called suction stainer.

In industry a range of suction strainer are available from 5LPM to 450LPM capacity. Generally they are connected by threading, and available from ½ to 2" BSP threads sizes.

Suction stainers are usually made of bronze, steel or stainless steel screening of 30 to 150 mesh size. They are pleated to increase surface area and wrapped around a perforated steel cylinder, as explained in following diagram.

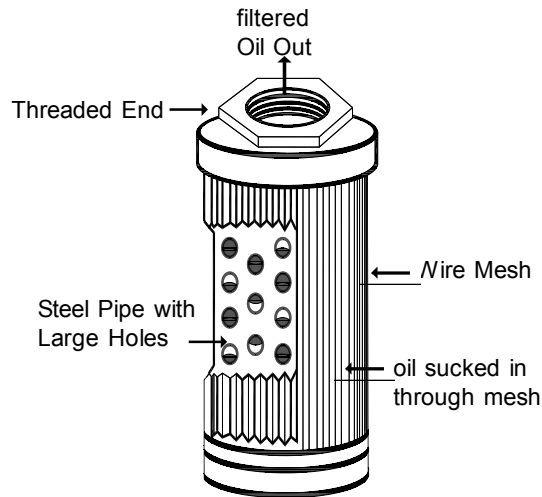

IN-TANK SUCTION STAINER

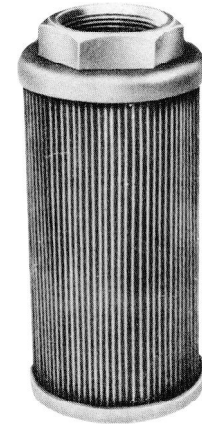

IN -TANK SUCTION STAINER
Mfg. by:- M/s. Hydax

Inlet line filter:-

Suction filters are also available which could be mounted outside tank. Such filter also could be fitted with visual indicator, which indicate the choking or clogging of the filter.

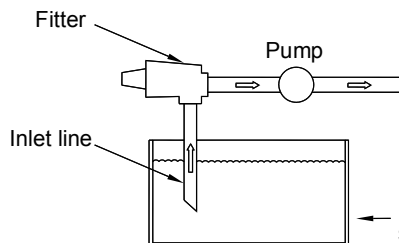
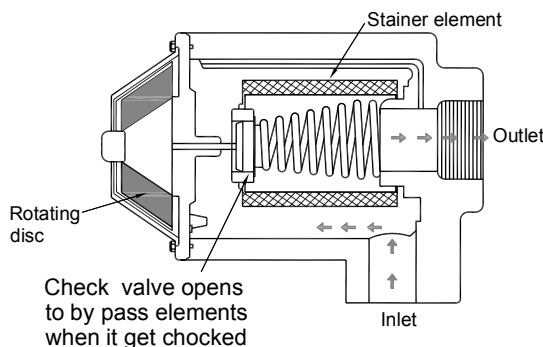

Inlet line filter connected before pump outside tank. (A 100 mesh size strainer can protect pump from particals upto 150 micron size)

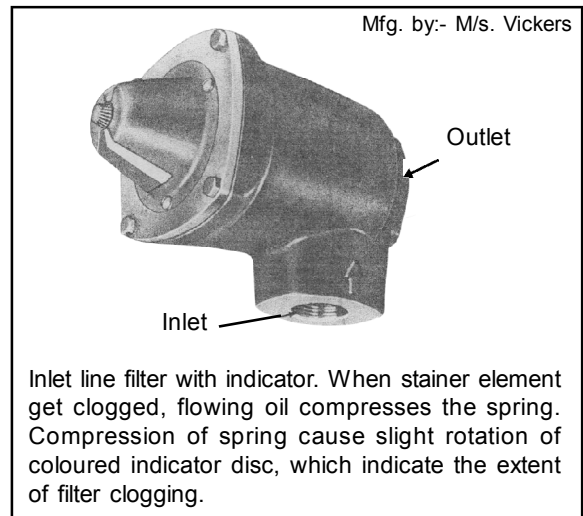

Inlet line filter with indicator. When stainer element get clogged, flowing oil compresses the spring. Compression of spring cause slight rotation of coloured indicator disc, which indicate the extent of filter clogging.

Websites of manufacturers:

- www.hydaxindia.com
- www.hydroline.com
- www.hydraulic-supply.com
- www.eaton.com/EatonCom/ProductsServices/Vickers

5.4 Return Line Filter

If on suction side of pump, a filter with too fine mesh size is used, then pump may not be able to suck oil through fine mesh and cavitations may occur. Hence either immediately after pump, or at exhaust line, filter with fine mesh sizes are used to clean oil.

A return line filter consist of a paper filter cartridge, and a by-pass valve, assembled together in a aluminium body. The construction of paper filter cartridge is similar to deisel or oil filter used in automobile engine. Check valve or by-pass valve, by-passes oil to system, when paper filter get chocked. By doing so, it saves the aluminium body of filter against permanent damage. It may also have a pressure gauge type of indicator. As paper filter element start chocking, it increases back pressure. This back pressure is indicated by pressure gauge. The amount of back pressure indicates the extent of filter chocking.

Filters at exhaust line are more common, and economical. Filter with 10 micron and 25 micron filtrations are more commonly available in industry.

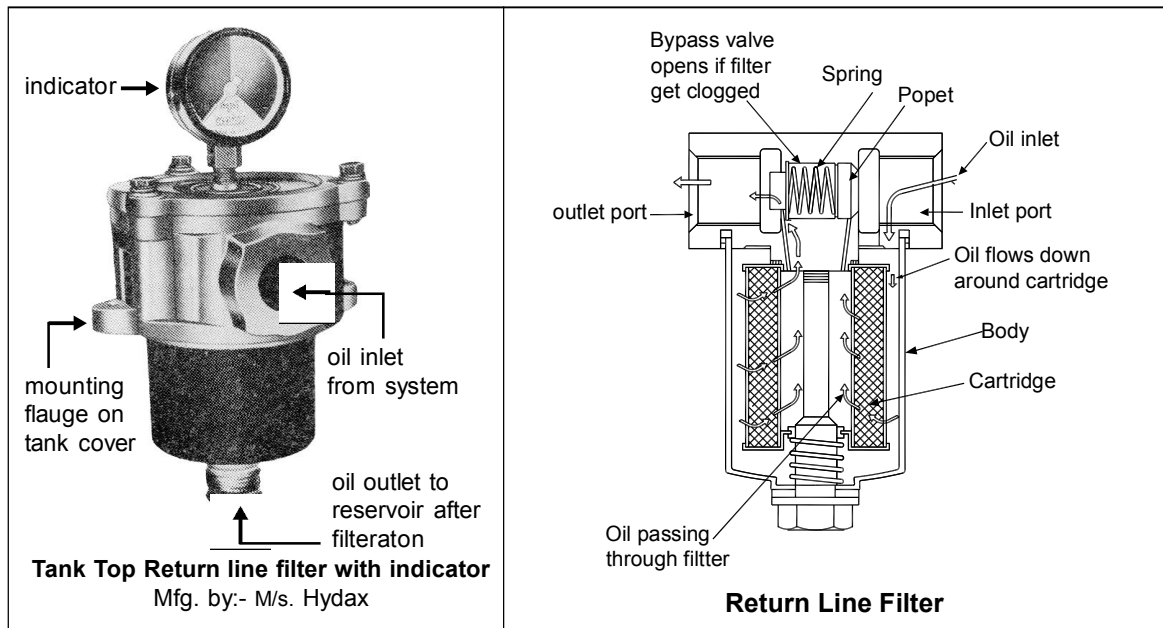
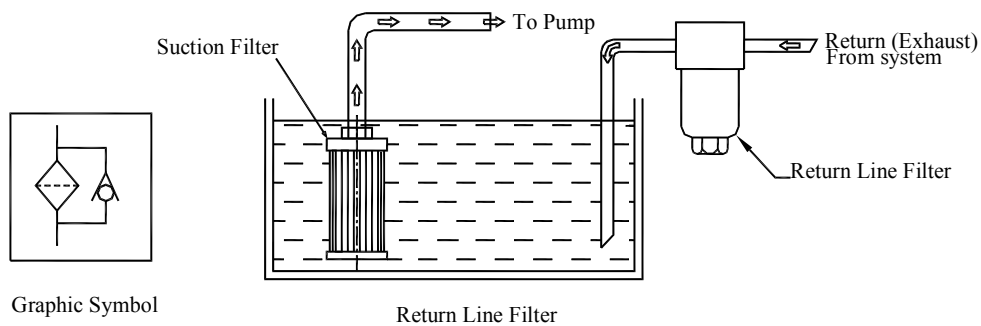

Return line filter is used at point where oil returns to tank. Depending on requirement of industry it is modified in two following ways:

First type we studied, in which said filter consist of a aluminium body, a paper cartridge and by-pass valve. In this type when filter get clogged, then only cartridge replaced.

In second type, the main aluminium body is made in two parts. First part of body is fixed to pipe line, tank top cover or manifold block, and second part of body consist of a aluminium housing fitted with cartridge and by-pass valve, and fitted to first part by threading. when filter get clogged then complete second part is replaced. This type is called spin on type return line filter.

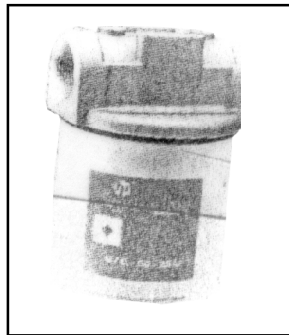

In line spin
on Return line filter
Mfg. by:- M/s. Hydroline

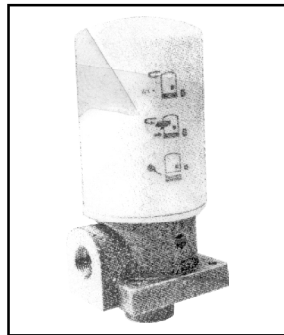

Tank top spin
on Return line filter
Mfg. by:- M/s. Hydroline



Sub-plate mounted
spin on return line filter
Mfg. by:- M/s. Polyhydron

Details about Filters and Stainers :-

1) National fluid power association gives definition of filters and stainers as follow:

- *Stainer is a coarse filter.*
- *Filter is a device whose primary function is retention of contamination from fluid by some porous medium.*
- As stainer is mainly made by wire net or screen, the filtering capacity of stainer is designated by mesh number or standard sieve number. Higher the mesh or sieve number, the finer the screen. A 150 mesh size can filter particles up to 100 micron size.
- Size of contaminating particle are measured in microns. Hence filters are designated by size of particle they can prevent from passing through them. If a filter is said to be nominal 10 micron size, that mean mostly it will trap particle of 10 micron size or above.

If a filter is said to be a absolute 15 micron size, that means, this is the maximum size of contamination, which can pass through filter. Above this size filter will never allow any particle to pass through it. A filter has both nominal and absolute rating, and nominal rating is smaller than absolute rating.

Websites of Manufacturers:

- www.hydaxindia.com
 - www.hydroline.com
 - www.polyhydron.com
 - www.dunham.thomasnet.com/catagory/equip-hydraulic-hose-fitting-eaton-vickers-filters
 - <http://dunham.thomasnet.com>
-

5.5 Pressure Line Filter

Some of the hydraulic valves such as servo-valves, proportional valves etc. are made too precisely. They are very costly and too sensitive to contamination.

To avoid any possibility of dust particle damaging the valves, less than 10-micron filters are used. Because of fine mesh size, some pressure is required to pass fluid through such fine filters. If they are used at suction line, then cavitation may occur. If they are used at exhaust line, then a constant backpressure will be created in system. Hence to avoid these two problems, these fine filters are fitted just after the pump, and before valves. Pressure line filter withstand the full working pressure of system.

The pressure line filter assembly after certain use start clogging or choking due to accumulation of contamination on the surface of filtering element. As choking increases, the pressure required to pass fluid through these filters also increases. Hence all the filters such as in line suction filters, return line filters, and pressure line filters have some means to indicate the extent of choking. It may be a rotating colour disc or a pressure gauge like indicator. And all the filters also have a simple type of relief valve. After choking, if filter elements are not cleaned or replaced, then instead of building-up pressure, fluid start by-passing filter through these relief valves. This saves the permanent damage to the filter body, but contaminated fluid start circulating in system without filtration, which may damage the whole system.

In filters, filtering elements are made from wire mesh, pipes, and sintered powder material. Wire mesh or win cloth filters are manufactured with a filtration capacity of 15 micron absolute, and for pressure differential as high as 300 kg/cm^2 . (suitable backups are provided to withstand high pressure and flow). Wire mesh filter could be cleaned and revised and are suitable for a very wide temperature range.

Paper elements filters are available up to 3 um absolute filtrations capacity, and a temperature range of 0 to 125°C . Paper filter elements are of throwaway type.

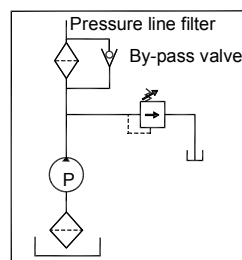

HYDRAULIC CIRCUIT DIAGRAM USING PRESSURE LINE FILTER

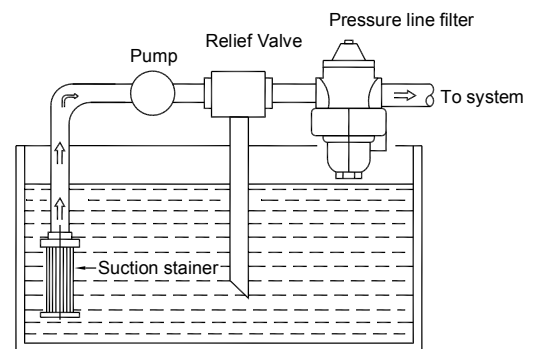

SYSTEM USING PRESSURE LINE FILTER

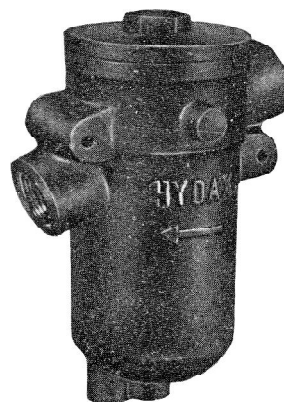

Pressure Line Filter
Mfg. by:- M/s. Hydax

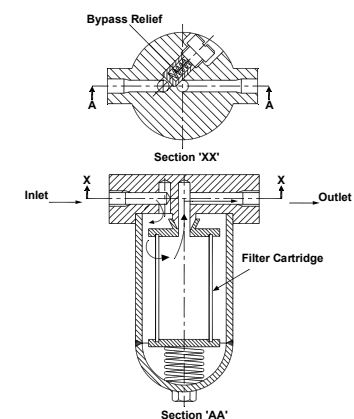

Cross section of pressure line filter

Websites of manufacturers:

- www.dunham.thomasnet.com/catagory/equip-hydraulic-hose-fitting-eaton-vickers-filters
- www.techno-filt.com/hydroaualicfilter.htm
- www.hydaxindia.com
- www.hydroline.com

5.6 Filler Breather Assembly

Filler breather assembly is combination of two units, that is filler and breather, and it is used to fill fluid in tank, and to filter air which is sucked in tank, when oil level drops in tank.

Filler could be an independent assembly or combined with breather assembly. Filler is basically a coarse filter, which only avoids large pieces of cloths or other particle entering in tank while filling the fluid. But it is not tool-proof system of complete filtering of fluid. Fluid should be separately filtered by filtering unit, and then pump in reservoir. Filler is only an opening with some precaution. Independent filler when not combined with breather, and when not in use, is plugged completely. It does not allow any liquid to pass in reservoir.

Breather is also a coarse filter with approximately 40 micron mesh size filtering. It filters air, which is sucked in tank. When it is combined with filler, we get compact filler breather assembly. Breather is also available separately. Following sketch will explain the construction of filler breather assembly.

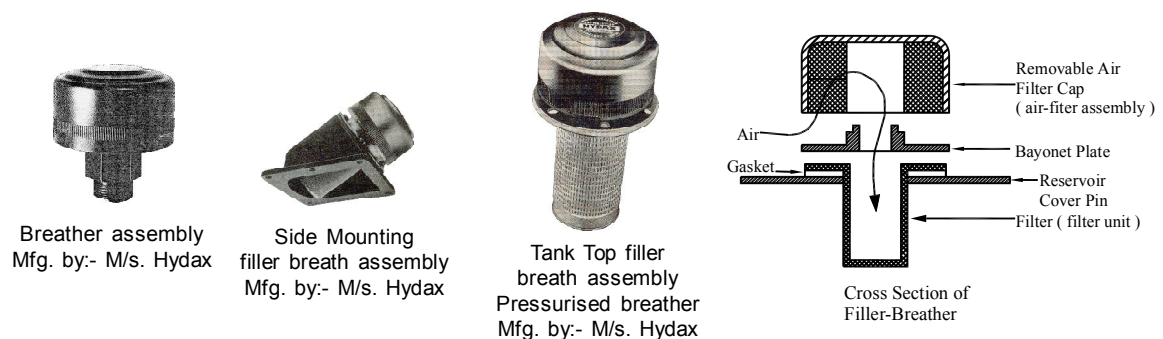

Pressurised Breather Assembly:-

Air is a major source of contamination. Hence constant breathing of air, that is suction and exhaust of air from

reservoir is not advisable in critical equipment. In such application pressurized breather is used. This device is similar to a conventional breather, but it incorporates a relief valve set at 0.5 or .075 bar, and a vacuum breaker. When oil level falls for first time, air enters the reservoir through the vacuum

breaker and filter. When the level rises, air above the oil level is compressed rather than expelled. Hence only the volume and pressure of air inside tank change, instead of breathing to atmosphere. This unit is also called check valve Breather filter.

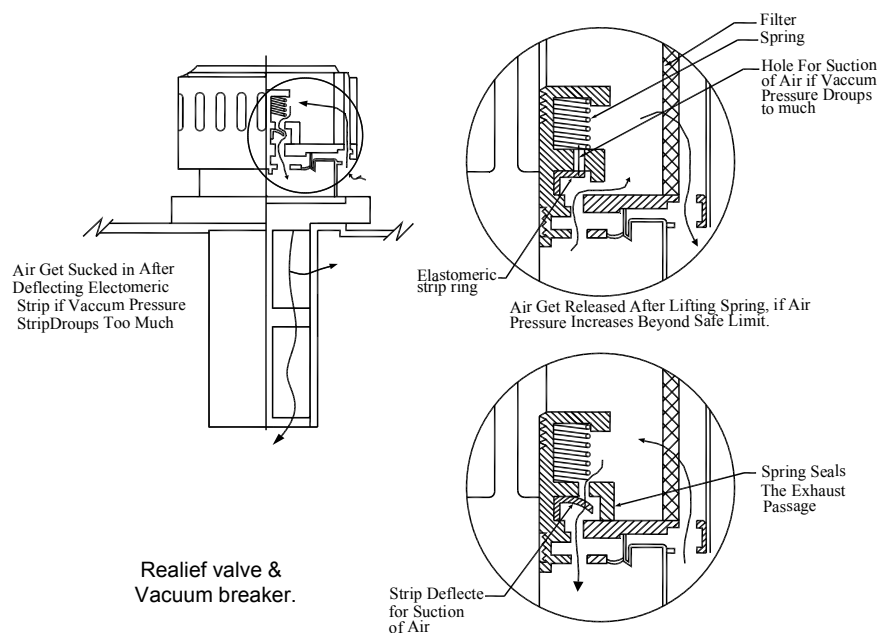

Websites of manufacturers:

- www.hyduxindia.com
- www.hydroline.com
- <http://www.purolator-facet.com/breather.htm>

5.7 Bell-Housing

There are two ways of fixing a pump to a motor. First by mounting motor and pump on a common flat base plate. Motor has its built-in feet, if pump is of foot mounted type then it is adjusted to the center line of motor and bolted to base plate. Or if pump do not have built-in foot but flange mounted, then a bracket is made, and then pump is mounted on bracket and coupled to motor, as shown in following diagram.

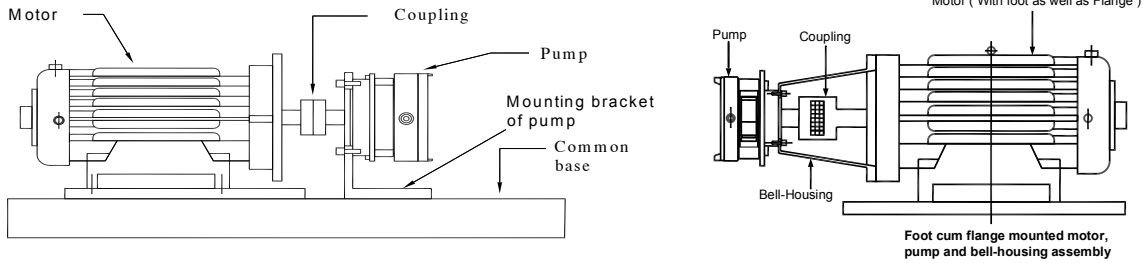

This arrangement requires large floor area, and it is too difficult to align the centre line of pump with centerline of motor. Misalignment results in damage of bearing of both motor and pump and fast wear and tear of coupling.

Second and most widely used alternative of fixing pump with motor is by means of bell housing as shown in following sketch.

Bell housing is casted or fabricated structure, and accurately machined. Motor mounted on one side and pump on other side. As it is accurately machined, hence it ensures perfect alignment of motor and pump assembly.

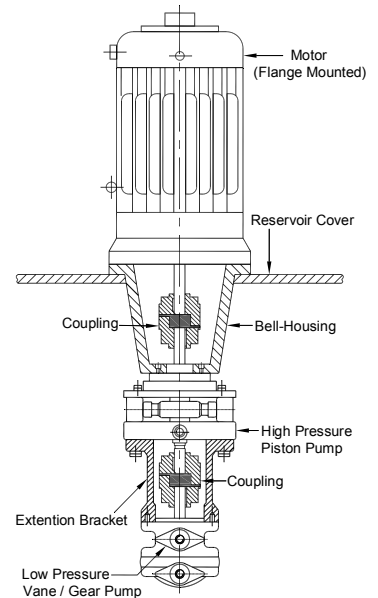

Assembly of Motor , Bell - Housing , Piston pump , Extension Bracket And Low Pressure Pump

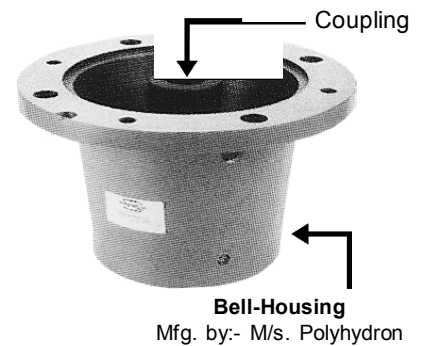
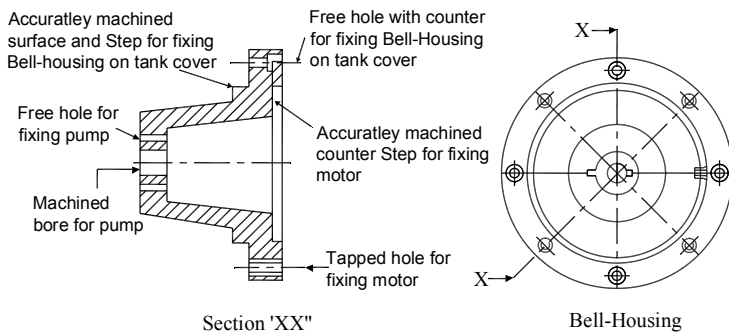

5.8 Extension Bracket Assembly

If two pumps are to be connected to a motor, then one alternative is to use motor of foot mounted type with shaft at it's both ends, and connect one pump at each end.

Second alternative is to select a high pressure piston pump with shaft extending to it's both sides. One side is coupled to vertical flange mounted motor, and second side is connected to low pressure gear or vane pump as per sketch No.5.8

The component which is used to hold low pressure pump firmly with piston pump is called extensive bracket assembly.

The Extension brackets are designed for coupling Low pressure hydraulic pumps having flanges as per ISO standards to Polyhydron make high pressure pumps (1R, 2R, 11R and 12R series). These Extension brackets are precisely machined to reduce misalignment of coupled shafts. The correct alignment of the shafts along with the cushioned power transmission through a resilient spider increases the life of the bearings of the Hi-Low pressure pump coupled. The construction also reduces the noise generation considerably.

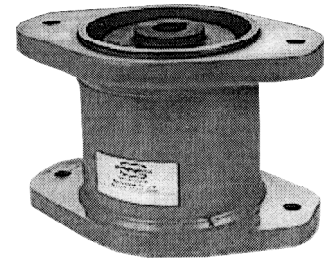

Extension bracket assembly
Mfg. by M/s. Polyhydron
sketch No.5.8

5.9 Coupling

Couplings are used to couple motor and pump or one pump with another pump. There are many types of couplings but two types of coupling more commonly used in hydraulic power pack units are:

1. Flexible Coupling or Gear type Coupling.
2. Spider Coupling.

5.9.1 Flexible Coupling: -

Flexible coupling consist of two hubs made from steel or casting and have external gear type teethes. Sleeves have internal gear and made from nylon or PTFE. (Polytera-flourotheylene). These types of coupling can accommodate slight mis-alignment and comparatively less damages to the bearing of pump and motor due to mis-alignment. Bell-housing is close from all the sides, and coupling could not be viewed and adjusted while engaging with pump and motor at the time of assembly. Flexible coupling could be used without any problem of assembly in such situation, hence this type of coupling is most widely used in hydraulic power pack and in industry.

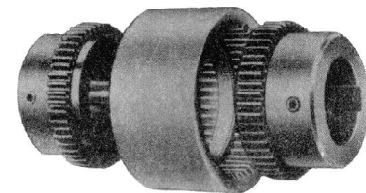
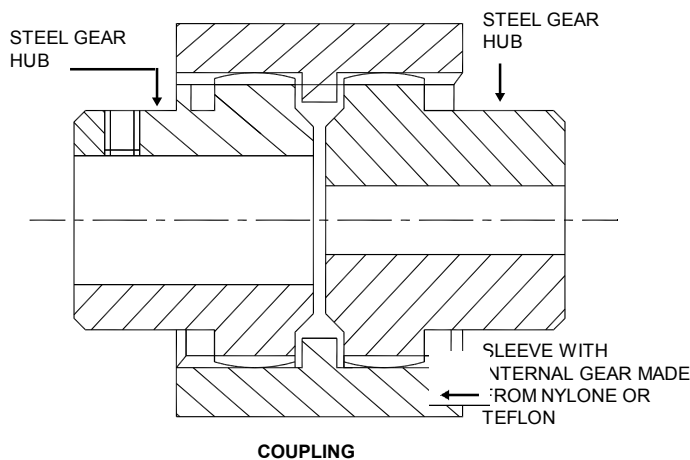

Coupling.
Mfg. by:- M/s. Hydax

5.9.2 Spider Coupling: -

Spider types of coupling are very common and used in industry since long time. It also has two hubs made from steel or casting, and synthetic rubber spider. Two hubs engage with each other and the synthetic rubber spider acts as cushion between them.

This type of coupling requires good alignment between pump and motor.

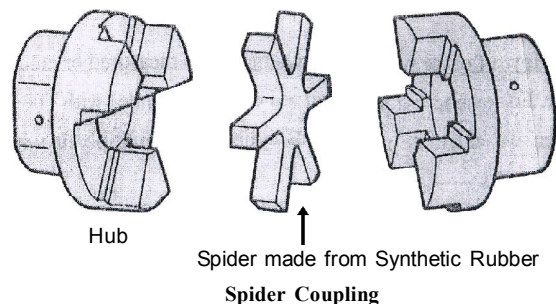

5.10 Pressure Gauge

Pressure gauge is used to read the pressure of hydraulic system. A faulty gauge may misguide while setting machine, and excessive pressure setting may damage the system. Hence a good quality pressure gauge is too important in hydraulic system. Following facts should be remembered while using pressure gauge.

- ◆ Pressure gauge should be very near to pump. As when oil passes through valves pressure drops. If oil passes through more numbers of valves, pressure drop may be excessive (say 15 to 20 kg/cm²). Hence if pressure observed at the actuator end, and then setting of pressure relief valve adjusted to get the required pressure, then pump has to develop 15 to 20 kg/cm² more pressure than the relief valve setting, to compensate for pressure drop.
- ◆ Pressure gauge commercially used in industry, uses “bourdon tube principle”. Bourdon tube is a curved pipe which when pressurized tries to straighten. One end of this curved pipe is fixed, and connected to pressure line, other end which is blind, is free to move as pressure applied. This movement, through ratchet and gear arrangement converted into rotary motion of pointer.

Bourdon tube is made from elastic material, hence after release of pressure it returns to its original position. But when it is over pressurized beyond its elastic limit, then it undergoes plastic deformation, and do not return to its initial position. Hence pointer also does not returns to zero or initial position.

All manufacturers claim that their pressure gauges can work up to maximum indicating capacity of their pressure gauge. But most of the time pressure gauge pointer does not return to zero position, after taking pressure up to its maximum capacity. Hence always use pressure gauge of double the more capacity than working pressure. That means, for 200kg/cm² working pressure use pressure gauge of 400 kg/cm² capacity.

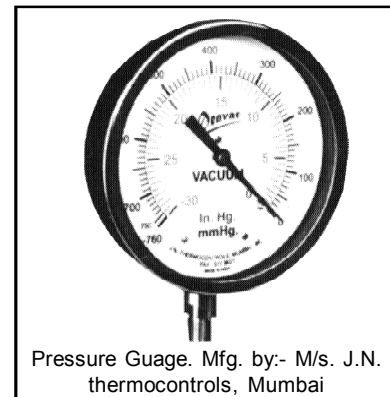
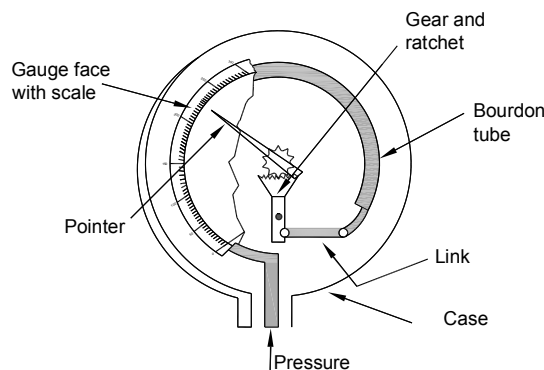

- ◆ **Pressure gauge with Diaphragm seal:-**

Pressure gauges are also used for measuring pressure of raw material under process. These raw materials may be corrosive in nature, such as acid etc., or may get crystallised or solidified in process, resulting in damaging the pressure gauge. Hence for such application a Diaphragm is used to seal (protect) pressure gauge from raw material fluid. Such Pressure gauges are filled with temperature stable fluid up to the diaphragm for sensing pressure of raw material across the diaphragm.

- ◆ **Pressure gauge with electrical contact:-**

Some-time based on value or intensity of pressure, some other electrical device may be activated or deactivated in a hydraulic system. In such cases, pressure gauge is also modified and equipped with electrical contact which either get engaged or disengaged on reaching set pressure and economical.

This is an additional feature of pressure gauge, other wise pressure switch is specially designed for sensing pressure and making and breaking electrical contacts.

Electronic pressure gauges:-

Electronic pressure gauges are very accurate and can measure very high pressure (as high as 14000 Bar), with dynamic response to over 1.5 MHz.

Electronic pressure gauge uses pressure transducer for sensing pressure. Most pressure transducers consist of some form of deflectable or deformable element that serves as the primary this element is measured by a secondary transducer, and the measurement is translated electronically in to a pressure reading.

Secondary Transducers may be a strain gauge, linear variable differential transformer (LVDTs), and inductive or capacitive strain transducers.

Some types of electronic pressure gauges and their feature are as follow:

- 1) **Portable Pressure Indicator :-** This is battery operated and portable pressure indicator with built-in sensor and LCD display. It is connected to the system by small diagnostic (quick connection) coupling.
- 2) **Digital Pressure Indicator :-** This unit is permanently connected to hydraulic system for sensing pressure, and electrically connected to control panel to draw current for it's won functioning and display. It indicates pressure in LCD display, it can also give 0.5 DC volt for analog recording.
- 3) **Digital Pressure Controller :-** This unit can indicate, as well as control the pressure of system. The setting of pressure inside controller is made by using potentiometer, and it can set one or two set-points.
- 4) **Microprocessor based Pressure Data logger :-** This unit records pressure over a period of time. The software used in it, enable us to set individual control, and alarm level for each channel. It can indicate pressure control, it sence the fault and correct it, and record correction over a period of time.

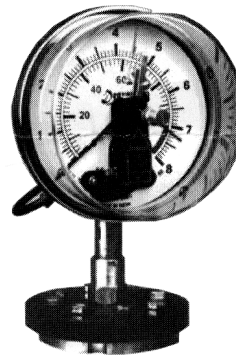

Pressure Gauge with Electrical Contact.
Mfg. by:- M/s. J.N. thermocontrols, Mumbai

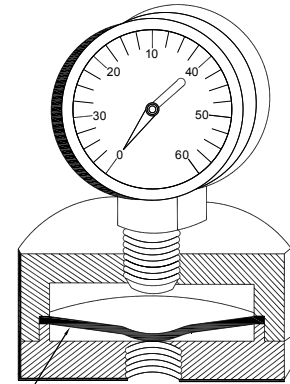

Diaphragm
Diaphragm protected gauge

transducers. Deflection of the measurement is translated

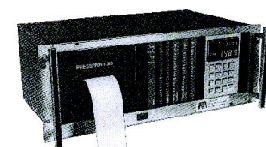
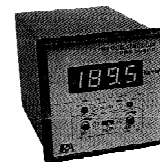

Mfg. by:-
M/s. Instrument Research Association Pvt. Ltd, New Delhi.

Websites of manufacturers:

- www.hydaxindia.com
- www.hydroline.com
- www.waaree.com
- www.hindustanhydraulics.com
- www.irainstrumentation.com
- www.jnthermocontrols.com

5.11 Pressure Gauge Isolator

- 1) Pressure gauge isolator is fitted in a hydraulic system to isolate pressure gauge when pressure reading not required.
- 2) In a production cycle of hydraulic machine, pressure in fluid varies minimum to maximum. And there are fluctuation and pulsation also. This causes constant movement of pointer of pressure gauge, because of which, it fails in a very short period of time. Once machine is set by adjusting pressure relief valve, then it is not required constantly to indicate and observe the pressure in system. Hence to increase the life of pressure gauge we isolate it from system, and connect to it whenever required. This connection and isolation of the pressure gauge from the system is done through the valve called pressure gauge isolator.

A needle valve could be used as pressure gauge isolator, but in this case pressure gauge should be isolated when there is no pressure in the system, otherwise pressure will be locked in the pressure gauge and the gauge will show the same reading even when there is no pressure in the system.

- 3) Pressure gauge isolator consists of a valve body, a sliding spool, a spring, and a knob. Basically it is similar to a two way direction control valve. When knob pressed against spring, spool shift to one side, and connect pressure gauge with system pressure to measure pressure. And when knob released spring forces spool back to its original position, and in this position it connects pressure gauge to tank. Hence pressure gauge do not remain under pressure for long time. This increases life of pressure gauge.

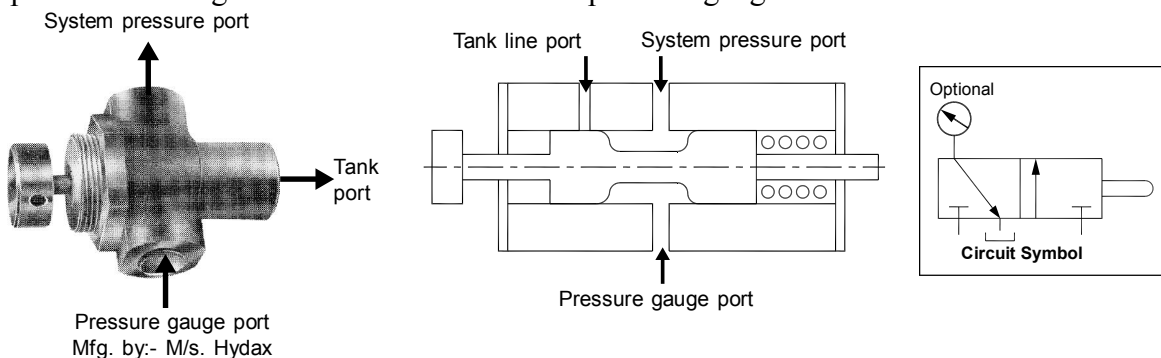

4. When a system need to read pressure at various points in multi pressure hydraulic system. Then for convenience, multi-station pressure gauge isolators are used. It replaces number of pressure gauge and single-station isolator needed to read pressure at various points.

In multi-station pressure gauge isolator, pressure could be viewed one by one, by using single pressure gauge and by indexing the knob

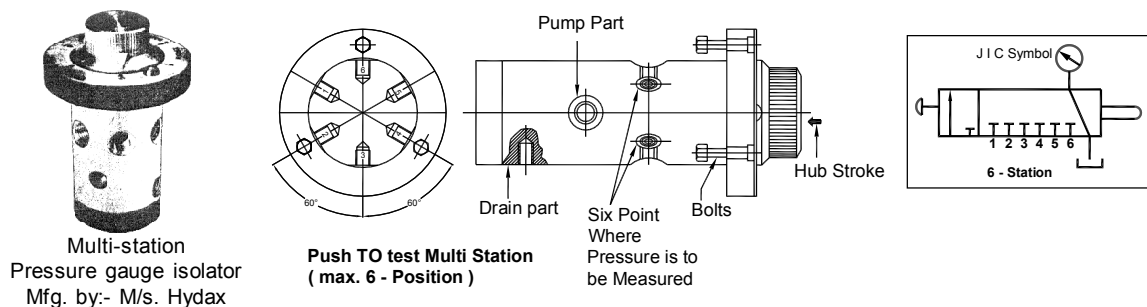

Websites of manufacturers:

- www.hydaxindia.com
- <http://www.process-controls.com>

5.12 Pressure Gauge Dampner

All pumps generate pulsation. For example if a piston pump has five pistons. Then in one revolution of shaft of piston pump, pump will deliver oil five times. Hence five pulses will be generated. Similarly vane pump and gear pump generate pulses according to number of their vane or number of teeth. Because of these pulses in pressure line pointer of pressure gauge vibrates. This vibration reduces the life of pressure gauge, and makes it difficult to read the pressure reading. Hence a pulsation dampener is used before pressure gauge to dampen by vibration of pointer. Glycerin is inert and a viscous material, it also dampens the vibration of pressure gauge component, So many times glycerin is also filled in pressure gauge to reduce vibration pointer.

To dampen the pulsation we basically restrict the path of oil, leading to pressure gauge. This is achieved by various method, few of them are as follows:-

- 1) By using porous element in path of oil.
- 2) By restricting passage of oil, either by pin hole or by screws arrangement.
- 3) By using thin and coiled capillary tube.

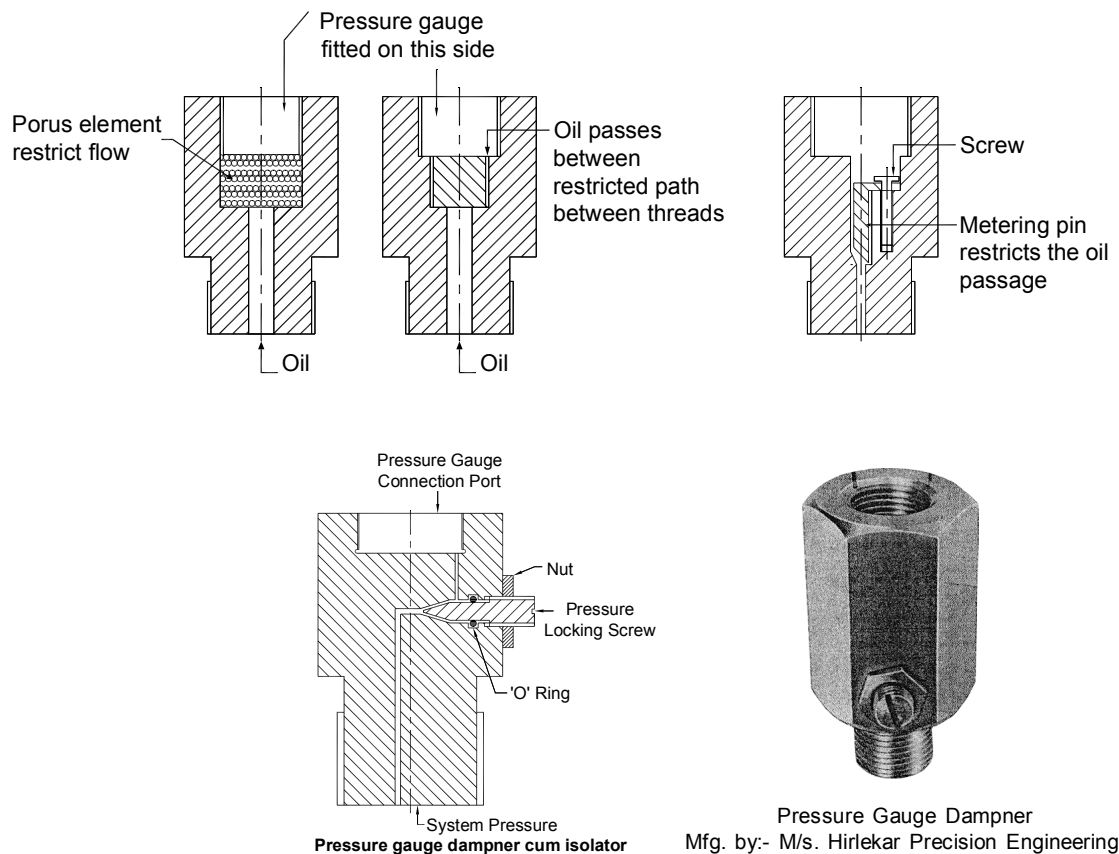

Some pulsation dampners also have features to isolate pressure gauge, similar to pressure gauge isolator. But they can not drain pressure gauge to tank. Hence while using this unit, pressure gauge should be isolated when there is no pressure in system.

Websites of Manufacturer:

- www.hirlekarprecision.com
- www.adarshpressuregauge.com

5.13 Heat Exchangers

Hydraulic systems are not 100% efficient. They do have power losses. If we assume efficiency as 80%, then the energy loss of 20% gets converted into heat. This heat gets absorbed by working fluid and their temperature starts rising. Above 50°C life of hydraulic fluid drastically reduces, viscosity gets decreased, which increases internal leakage and loss of power, and further increases the temperature. Hence to avoid this regular removal of heat from hydraulic fluid is necessary.

This is done in four ways: -

- 1) Heat radiation from surface of oil tank.
- 2) Oil cooling by air-cooled-heat exchanger.
- 3) Oil cooling by water-cooled heat exchanger.
- 4) Oil cooling using refrigerator or chiller unit.

Heat Radiation:-

As a thumb rule about 5 sq. ft surface area of oil tank dissipates approximately 0.25 hp of heat. Hence by providing large oil tank, heat generated in small quantity could be dissipated by radiation and oil temperature could be kept within safe limits.

Air cooler:-

When heat generated is slightly more than what could be dissipated by surface of reservoir, then an air-heat exchanger is used. These are similar to radiators used in cars. But construction of radiator used for oil cooling is more stronger than car radiator to withstand back pressure of hydraulic system. Air is passed over fins by an additional electric motor.

There are few models in which a fan is fixed to the coupling between the prime mover (motor) and pump, and finned tubes throughout with oil is circulated surround the coupling and fan.

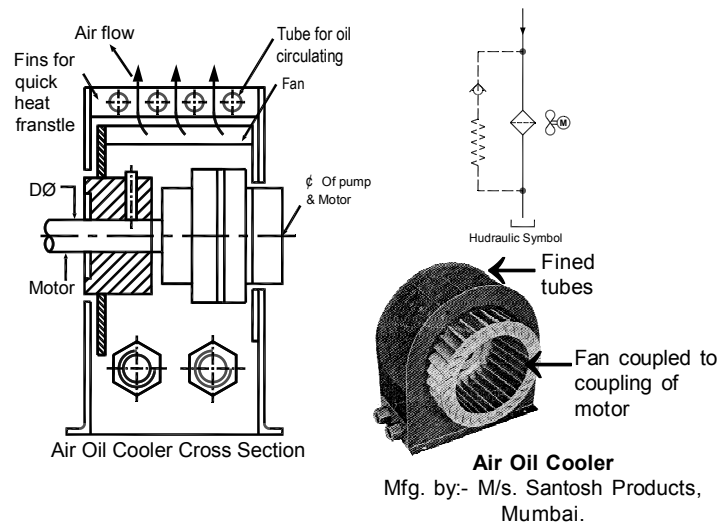

It is circular in form. This type of air-cooler is compact, but used for small systems only.

Drawback of air cooler is that they can not cool below ambient temperature, and generally oil temperature remains 5°C above ambient temperature, and initial cost is high as compared to water cooler.

When oil is forcefully passed over fins of radiator by fan, then such Air-Coolers are called Air-Blast oil coolers.

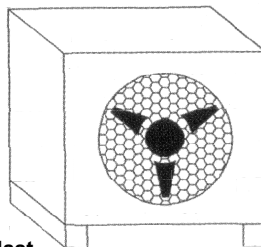

Air Blast

Mfg. by:- M/s. Maruthi Cooling System

When air is sucked over fins of radiator by exhaust fan, then such coolers are called Air-oil Coolers.

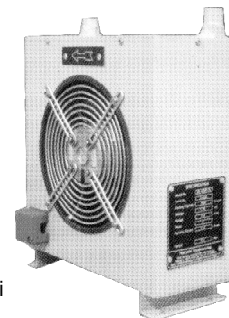

Air-oil Cooler.

Mfg. by:- M/s. Maruthi Cooling System

Addresses or websites of manufacturers:

- www.swep.net
- www.maruthicoolingsystems.com
- Santosh Products : 8, Sardar Pratap Singh Industrial Estate No.1, LBS. Marg, (W) Mumbai-400078

5.14 Water Cooler

In case of those machines, in which heat generation is too high, or in summer season when ambient temperature in most of the part of India crosses 40°C then air-cooler could not dissipate sufficient heat. In such condition, cold water is used as cooling medium, and oil is cooled by using water cooled heat exchanger. For example injection molding machine which are operated 24 hours, for such machine air cooler is not sufficient. There are two types of water cooled heat exchanger.

1) Shell and Tube Type Heat Exchanger –

In shell and tube type water cooled heat exchanger, hot oil is passed over copper tubes, and cold water passed through the copper tubes, to extract heat from oil. Cross section of said heat exchanger is as follow.

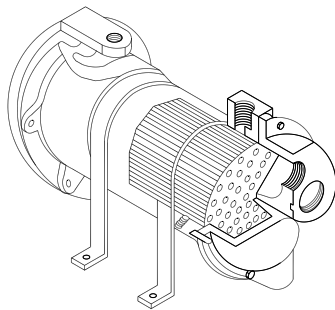

Liquid - to - Air Heat Exchanger

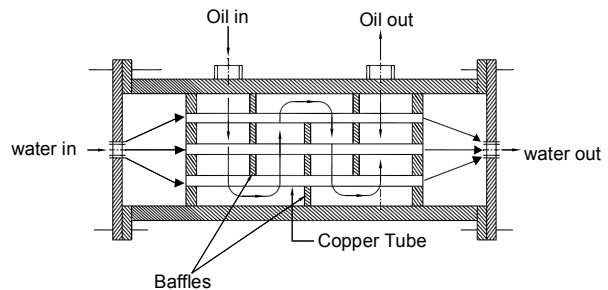

2) Plate – Type Heat Exchanger –

These are compact and flexible heat exchanger. A plate heat exchanger consists of a number of corrugated plates with gaskets placed in grooves along the edges. The adjacent plate comes into contact with each other where the rider meet. During assembly the channel plate are pressed together in a frame to form a tight and efficient heat exchanger.

M/s. Ind. Swep Energy System Pvt. Ltd manufactures this type of heat exchangers in India. Visit their web site. www.swep.com, to study more details.

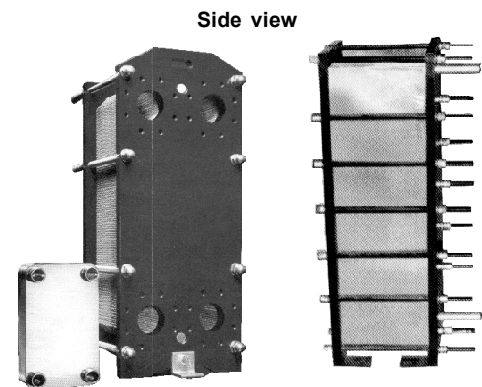

Plate type Heat Exchanger
Mfg. by:- M/s. Ind Swep Energy Systems,
Pune

Websites of Manufacturers:

- www.swep.net
- www.maruthicoolingsystems.com
- www.nationalcoolingtowers.com

5.15 Oil Cooling by Chillers

Chiller is like window air – conditioner, but instead of room air, it cools oil. Chillers are of two types. In first type the refrigerant is cooled by air, similar to the window air conditioner. While in second type, where too much heat is to be removed from oil and ambient temperature are high, then refrigerant used in chiller is cooled by water cooled heat exchanger and cooling tower.

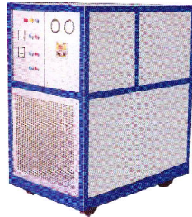

Air-cooled chiller

Mfg. by:- M/s. National Engineering

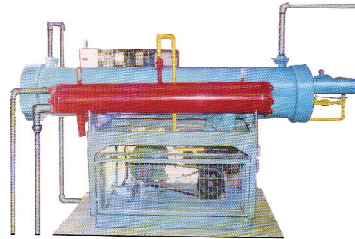

Water-cooled chiller

Mfg. by:- M/s.National Engineering

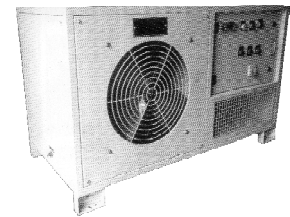

Air-cooled chiller

Mfg. by:- M/s. Maruthi

Websites of manufacturers:

- www.swep.net
- www.maruthicoolingsystems.com
- www.nationalcoolingtowers.com

5.16 Cooling Tower

Some time ambient temperature becomes to high or too much heat is to be extracted from oil, in such situation cooling water circulated through water cooled heat exchanger also become hot, and it is required to first cool the circulating water before circulating through heat exchanger. In such case cooling tower is used to cool the water. A cross section of cooling tower is as follow:

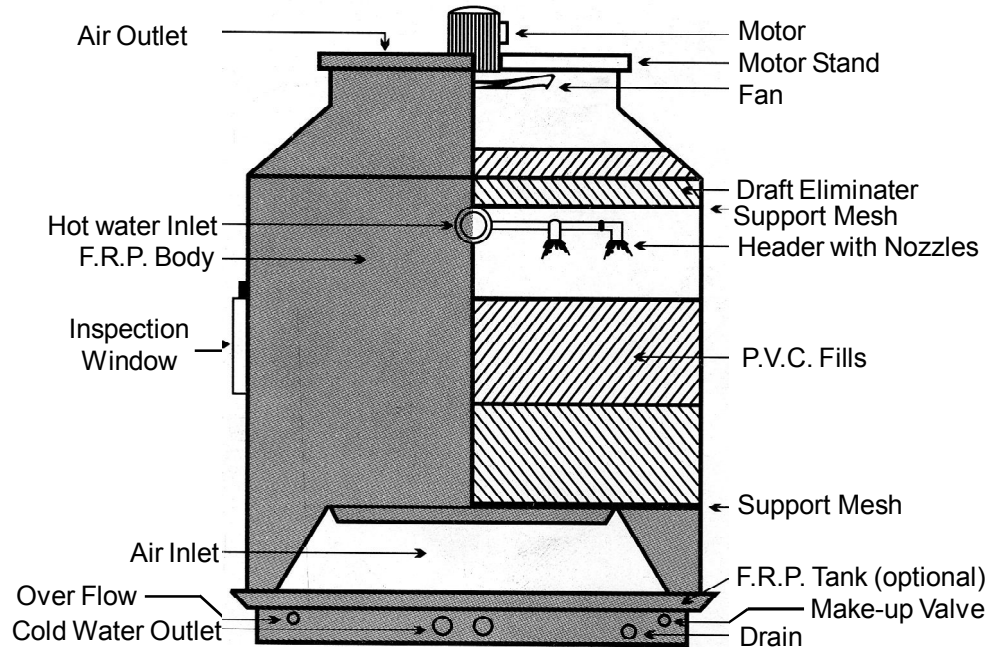

F.R.P. COOLING TOWER
Mfg. by M/s.National Engineering

Cooling tower is also used to cool the circulating water, which is used for cooling of condenser of oil cooling chiller.

5.17 Heater

Generally hydraulic systems are designed for hydraulic oil with viscosity between 32 to 68 cSt. If viscosity falls below 32 cSt, oil becomes too thin and internal leakage between components of valve and pump increases, and if viscosity increases beyond 68 cSt, the oil becomes too thick and pump could not suck it through suction filter. This causes cavitation in pump casing, which damages the pump.

When ambient temperature becomes too low, then oil is heated to maintain its viscosity. Heating could be achieved by circulating hot water in shell and tube type oil cooler, or it could be heated by electric heater.

For electrically heating oil, heater with low-heat-density design (10 watt, per square inch) is used, so that oil should not start burning.

Heater is placed very near to pump suction and thermostatically controlled.

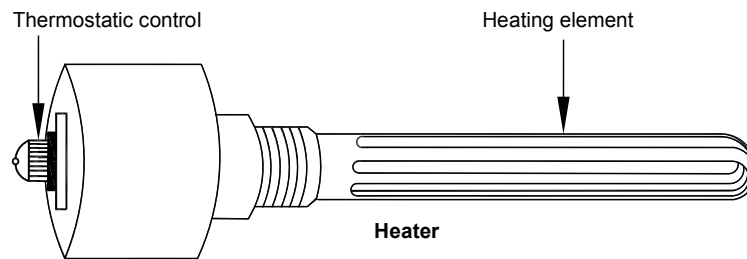

Websites of manufacturers:

• www.warrenelectriccorp.com/applications/hydraulic-oil-heaters/default.asp

5.18 Fluid Level Indicator and Controller

If hydraulic pump runs dry (without oil) even for few minutes, then because of friction internal components of pump get over heated, get sieged, and gets permanently damaged. Hence by mistake also system should not run dry. Oil level falls bellow suction level of pump due to leakage in pipeline, actuating very large size of cylinder for the first time, and natural evaporation of oil etc. Such fall of oil level happen even without the knowledge of operator. Hence to safe guard pump against any human error, and against running dry, fluid level controller is used.

Fluid level controller is a simple electric switch, which get actuated when fluid level fall bellow particular level. The actuation and sensing of level may be by mechanical or by electromagnetic means. Various manufacturers makes different types of fluid level controller. Visit their Website, to study more details about fluid level controller.

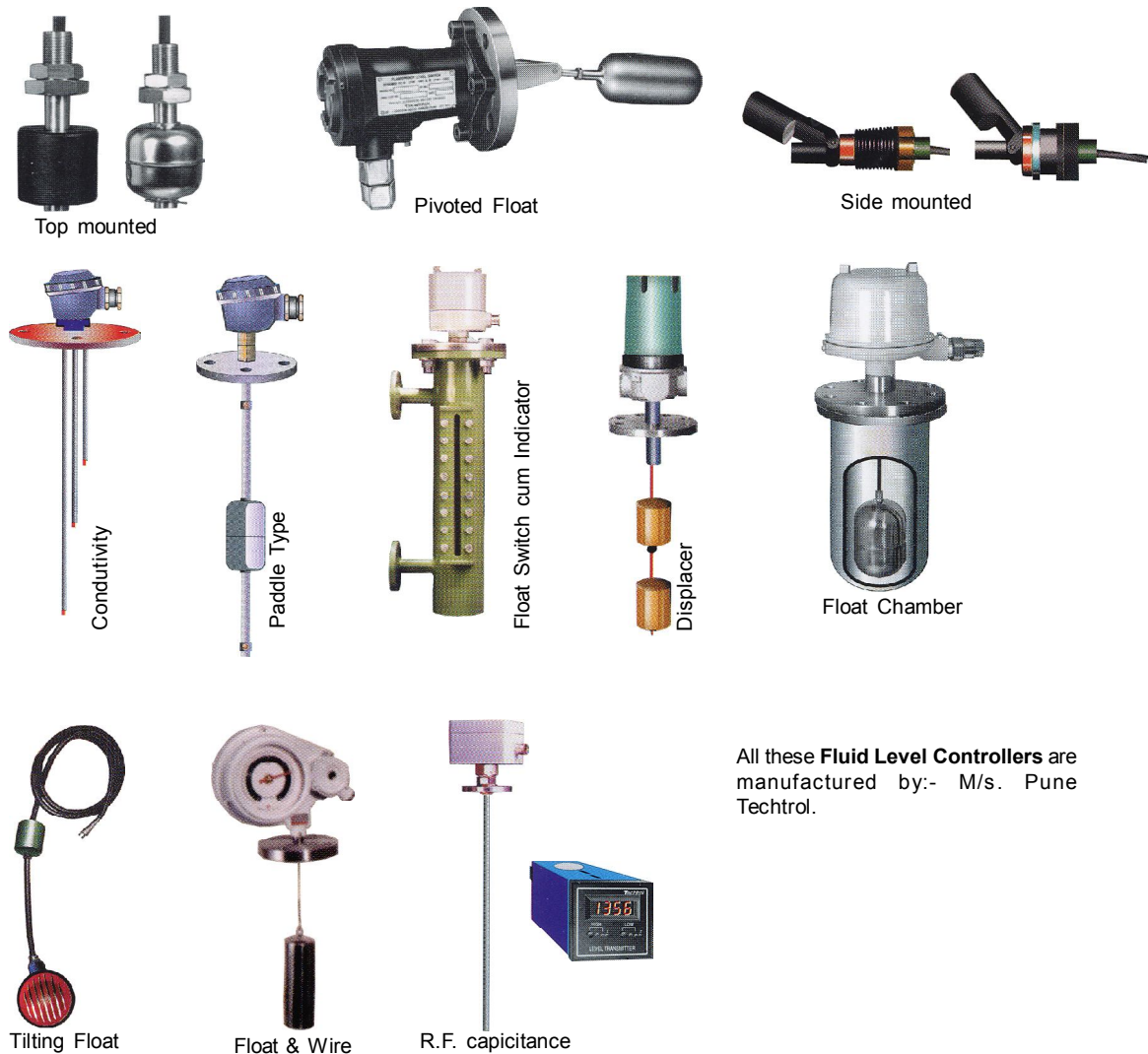

All these **Fluid Level Controllers** are manufactured by:- M/s. Pune Techtrol.

Websites of manufacturers:

- www.punetechtrol.com
- www.waaree.com
- www.kobold.com

5.19 Flow Meter

1) Turbine Meter:

It consists of a turbine, or vane, or a propeller fixed to the centre of a flow path. When fluid flows it rotates the turbine, and rotation is proportional to the flow. Hence to calculate flow, rotation of turbine is measured. To measure the rotation either shaft of turbine is geared directly to the meter or magnetic element are used.

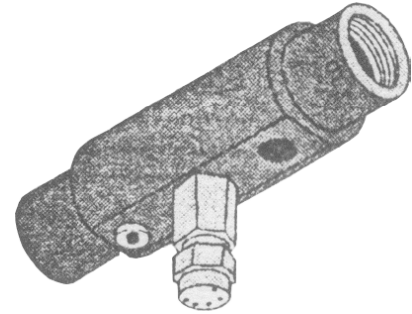
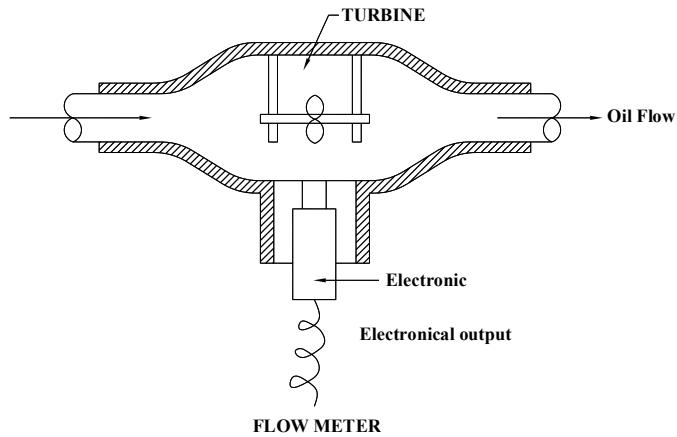

Turbine Meter
Mfg. by:- webster-instruments

2) Positive Displacement Meter:

It is similar to the hydraulic motor. When oil passes through this unit, the shaft rotates. This rotation is indicated on a read-out scale to indicate the flow rate.

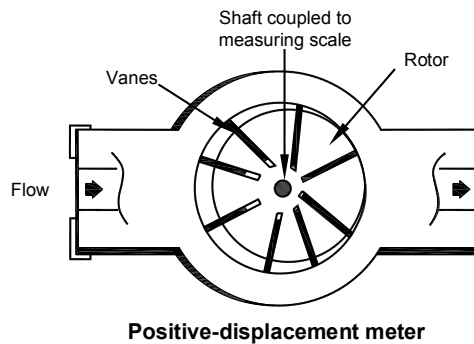

Rotating Vane Flowmeter
Mfg. by:- KOBOLD Messring GmbH

3) Orifice type of Flow Meter:

In this type arrangement a sharp edge orifice and a tapping spring-loaded piston is used for flow measurement. Piston is attached to a magnet, and out side pipe line, and within it's magnetic field a pointer is also attached to magnet. When oil flows, it pushes piston back. This shifting of piston also changes magnetic field, and proportionally magnet attached to pointer, also rotates to get aligned with magnetic field. This rotation is measured and indicated on a scale to measure flow of oil through orifice.

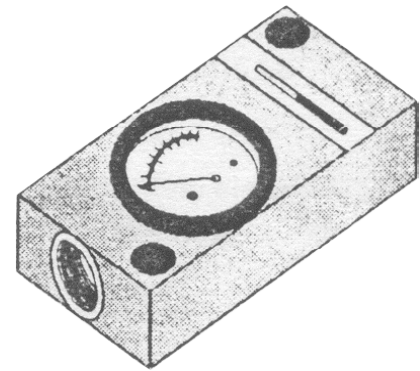
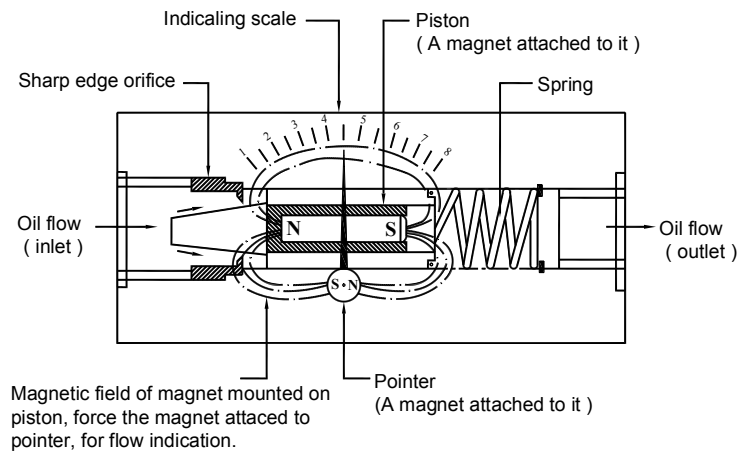

Orifice type of Flow Meter
Mfg. by:- webster-instruments

4) There are many types of flow meters which function on various principles, some of them are as follows:

- 1) Vertex meter
- 2) Fluid oscillator meter.
- 3) Pilot tube type flow meter.
- 4) Venturi and flow nozzle type flow meter.
- 5) Jet deflection meters.
- 6) Turbine flow meter.

For more details about working principle and measurement techniques, kindly refer to a book of measurement systems. Few of them are as follows.

- 1) MEASUREMENT SYSTEMS, APPLICATIONS AND DESIGNS
By: Ernest O. Doebelin
Publisher: McGraw Publishing Company, New Delhi.
- 2) A COURSE IN MECHANICAL MEASUREMENT AND INSTRUMENTATION
By: A.K. Sawhney and Puneet Sawhney
Publisher: Dhanpat Rai & Co. (P) Ltd. Delhi - 6

Websites of manufacturers:

- www.waaree.com
- www.kobold.com
- www.webster-instruments.com

5.20 Temperature Indicator and Controller

Optimum temperature range of hydraulic fluid is 40°C to 50°C. Above this range life of oil reduces. Hence temperature indicators are used to check the oil temperature regularly. There are three types of temperature indicators. First is simple thermometer, which is fixed in oil level indicator, hence oil level as well as temperature could be viewed any-time.

Second type is dial type indicator. This unit has a probe or sensor, which is immersed in fluid, and dial indicators are similar to pressure gauge, and temperature is indicated through a pointer.

The third and most widely used type is Electronic Temperature indicator cum controller. This unit has a thermocouple type sensor which is immersed in oil, and electrically connected to an electronic controlling unit with LCD display. This unit indicates as well as controls the temperature by either switching off the main motor, or by actuating a cooling device.

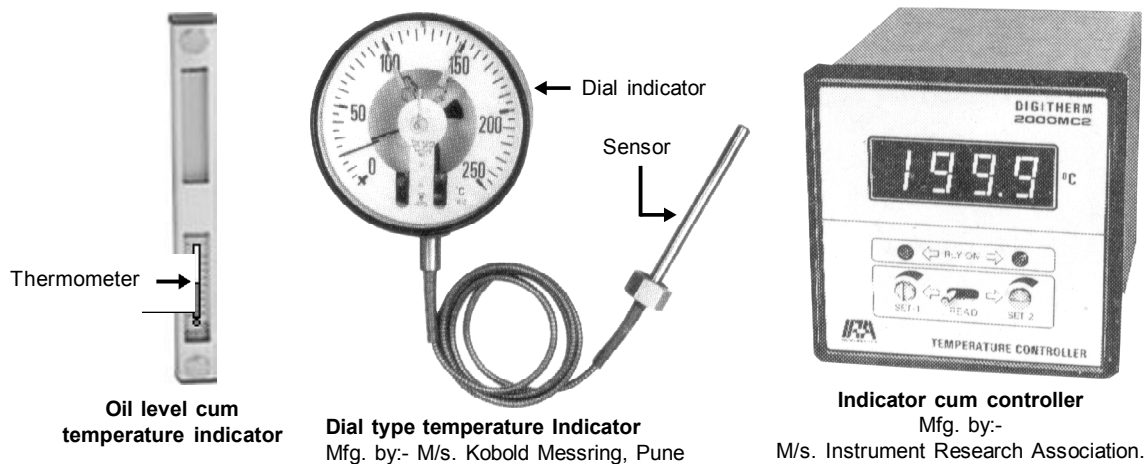

Websites of manufacturers:-

- www.kobold.com
- www.irainstrumentation.com
- www.nutronicsindia.com
- www.scientificcontrols.com
- www.precimeasure.com

5.21 Magnetic Separators

Magnetics separators are dipped in oil so that the ferrous particles get attached to it, and are separated from oil. This reduces the load on the filter .



Magnetic Tank Cleaner :-

It is efficient in picking ferrous particles. It consist of large ceramics magnets- and sturdy in construction.
(Mfg. by:- M/s. Hydroline)

Websites of manufacturers:

- www.hydroline.com

5.22 Pipe Clamp

Hydraulic pipes and tubing and hoses are required to be fasten rigidly due to following reason.

- 1) Hydraulic pipes, tubing and hoses are subjected to very high and fluctuating pressure. Under pressure every curved pipe try to straighten like a burden tube of pressure gauge.
- 2) Hydraulic pipe tubing and hoses are subjected to vibration, and because of vibration the end fitting start loosing
- 3) Because of any reason when hydraulic pipe and hoses snaps-out from it's end fitting under pressure, then it swings in air with great force and speed, which can cause a fatal accident

Because of these reasons the hydraulic pipe, tubing and hoses are fasten very rigidly, so that no undue straightening force transferred to the end fitting. End fitting does not get loosen due to vibration, and if due to any reason, pipe and hoses snaps-out from end fitting, it does not cause a fatal accident.

Pipe clamps are simple metallic clamp, designs to hold hydraulic pipes and hoses in position rigidly. Glavanised to avoid corrosion, and fitted with oil resistant rubber lining to absorb vibration of pipe, and protect outer rubber coating of hose pipe.

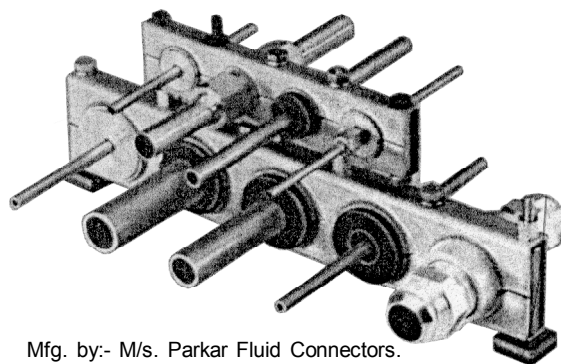
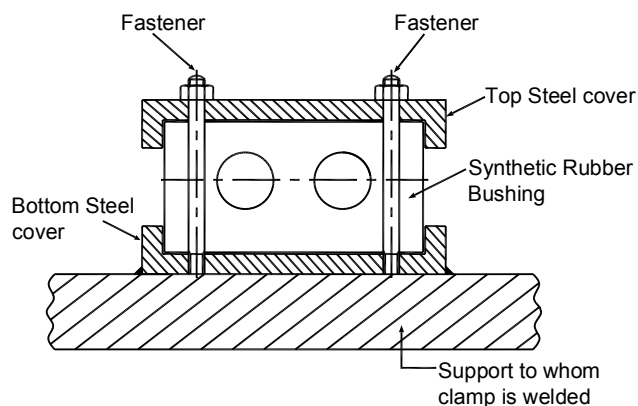

Mfg. by:- M/s. Parker Fluid Connectors.

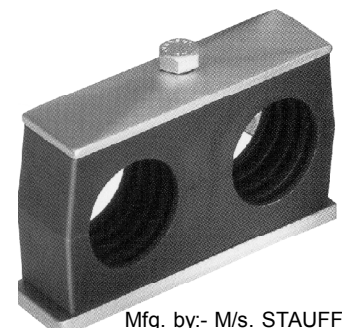
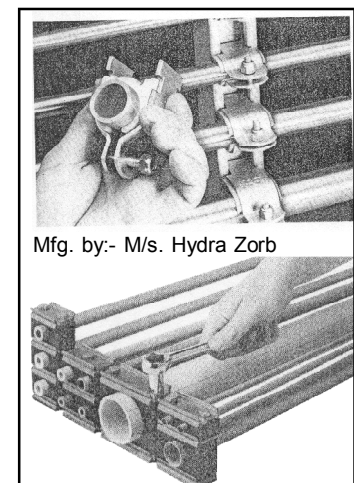

Mfg. by:- M/s. STAUFF

Addresses of manufacturers:-

- www.parker.com
- www.hydra-zorb.com
- www.stauff.com

5.23 Diagnostic Couplers

These are small size of quick connection coupling, and specially designed to diagnose hydraulic system. Male part of quick connection coupling is fitted at various places in a hydraulic system, where we have to measure pressure to solve hydraulic problems, and malfunctioning. And whenever such maintenance problems arises, female part of quick connection coupling is attached to a pressure gauge, and then engaged male coupling to measure pressure at various points. By doing so, in very short time, without wasting oil, pressure could be checked at critical points, and problem could be diagnosed easily and quickly. Diagnostic couplings are also modified to measure temperature of oil, by inserting sensor deep in pipe line.

These small diagnostic couplings are sold with trade or commercial name. M/s. Hydrotechnik (Germany) sales diagnostic coupling with trade name of Minimesh test point.

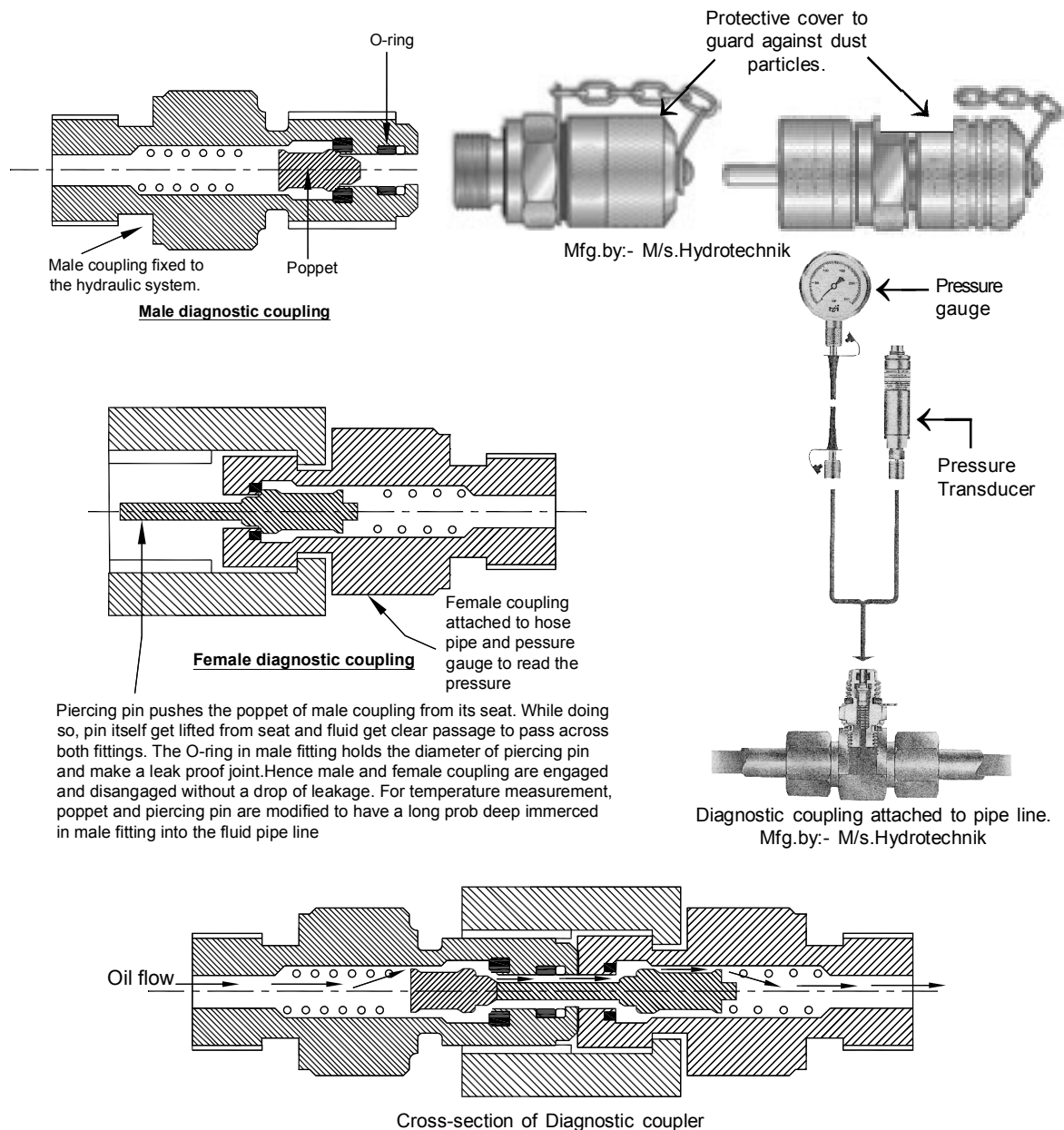

Websites of manufacturers:
• www.hydrotechnik.com

5.24 Diffuser

When suddenly pressure from large size of cylinders get released, a surge of oil returns to tank. At exhaust the velocity of oil becomes to high and it causes a splash in oil tank, which causes turbulence, aeration, foaming and noise. To avoid this we fix a diffuser at exhaust line inside tank. It consists of two concentric cylinders with holes on its surface. These holes direct the flow of oil in opposite direction. The multiple changes in flow direction reduces the oil velocity.

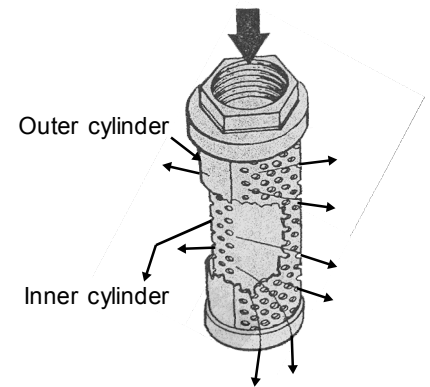

Websites of manufacturers:-

- www.lenzinc.com
- www.chemical-injection-pumps.com
- www.hydroline.com

5.25 Hydraulic Fuse

Hydraulic fuse functions similar to electric fuse. Hydraulic fuse is basically a disc which ruptures or blows out a preset pressure level.

Hydraulic fuses are used in system, where there are possibility of very high rate of pressure rise. (for example 10,000 bar per sec.) If conventional relief valve fails to release high pressure with in fraction of second then hydraulic fuse blows out and by-passes oil back to reservoir.

Hydraulic fuse can not be re-set, it has to be replaced. And system remains inoperative until the fuse is replaced.

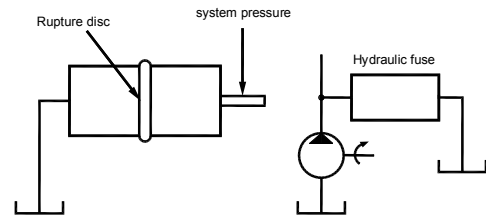

5.26 Flexible Separators

• Air breather is fitted on tank top. So that whatever air sucked and exhaust from tank are filtered. But in long run these filter gets chocked and nobody replaces them due to negligence. Hence nowadays top surface of oil inside reservoir is also covered with a flexible rubber sheet. This sheet prevents air particles mixing with oil, hence keeps oil clean for very long period of time. And as it is flexible, hence it deflects along with level of oil without creating pressure or vacuum in oil.

M/s. FCH Olaer Group manufactures such type of Air-oil separator.

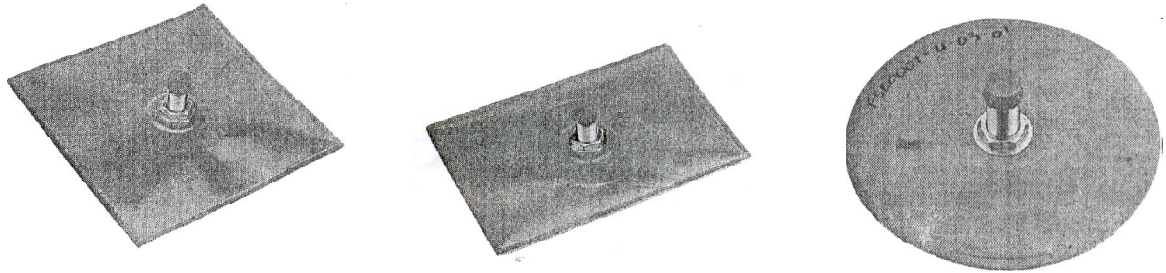
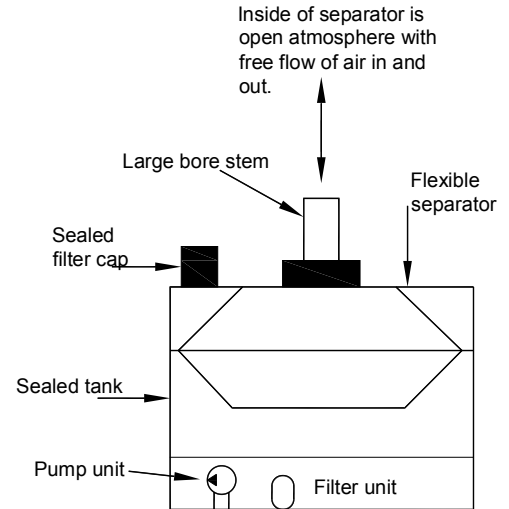

Flexible Separators Mfg. by M/s. FCH Olaer Group

Section-B
ACCESSORIES FOR BETTER
FUNCTIONING OF
HYDRAULIC MACHINES

5.27 Oil Cleaning Unit

These units are specially designed and manufactured to clean and filter oil of hydraulic power unit. Every hydraulic power pack do have suction filter, filler cum air breather, return line filter etc. But some time either they get choked or damaged, or we by-pass them, while maintaining and servicing system, or filling oil. Or some time addition of contamination is so high that they are not removed by regular filtering, and thus keep on accumulating in oil. In such case, oil has to be cleaned by using external oil cleaner to increase life of hydraulic system.

Oil cleaners are of two types.

Conventional Oil Cleaner :-

This unit is also called **Portable Filter**. This unit consists of a suction filter, a pump, a motor, a return-line filter and a by-pass valve. It sucks oil, through suction filter, and returns oil to system through a return line filter with 25 to 10 micron filtration capacity. Hence by constant circulating oil through these filters, oil gets cleaned. These units are also widely used for filling new oil in hydraulic reservoir.

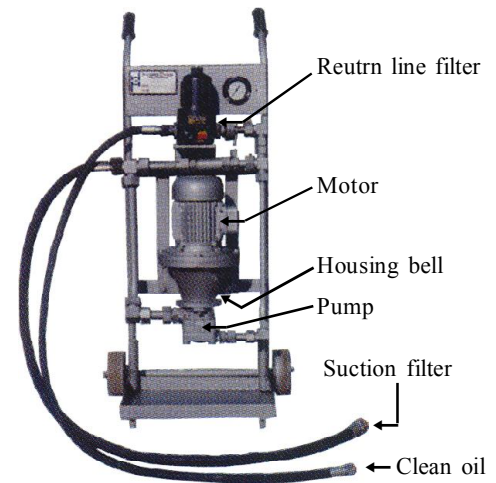
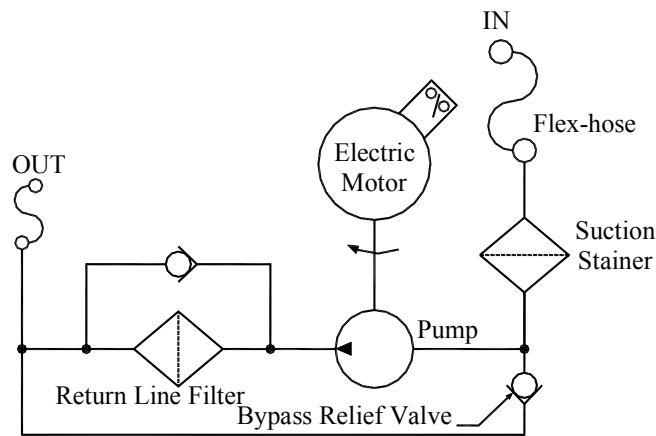

Mfg. by:- M/s. Hydro Dyne Industries. exhausted to tank

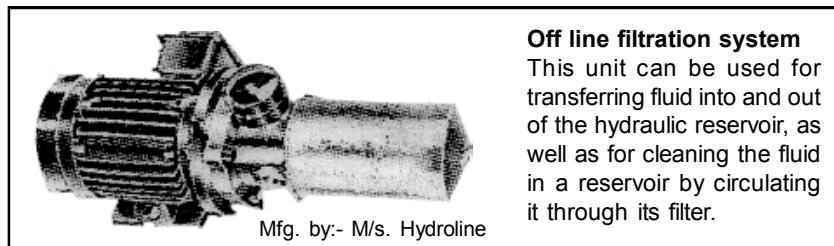

Off line filtration system

This unit can be used for transferring fluid into and out of the hydraulic reservoir, as well as for cleaning the fluid in a reservoir by circulating it through its filter.

Mfg. by:- M/s. Hydroline

Electrostatic Liquid Cleaning (ETC):-

1) Majority of Contamination particles in oil are either positively or negatively charged, due to contact potential difference with oil. When such contaminated oil passes through an electric field, the positively charged particles get attached to negative pole and negatively charged particles get attached to positive pole.

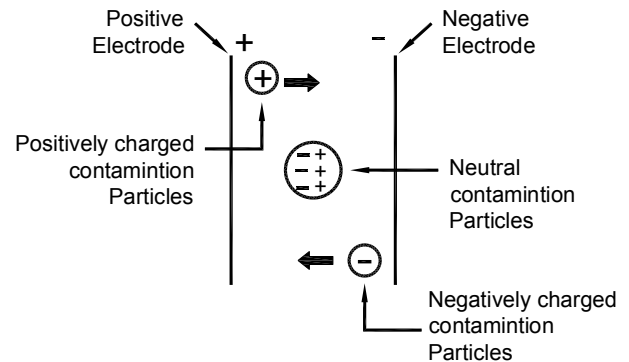

when corrugated dielectric media (collectors or filter paper) are inserted between electrodes, the electric field between these two electrodes gets deformed, and dielectric polarization occurs at the tips of the corrugation. The electric field is strongest at the tips, and the particles are drawn and deposited on opposite electric poles and removed from oil along with dielectric media (filter paper or collector).

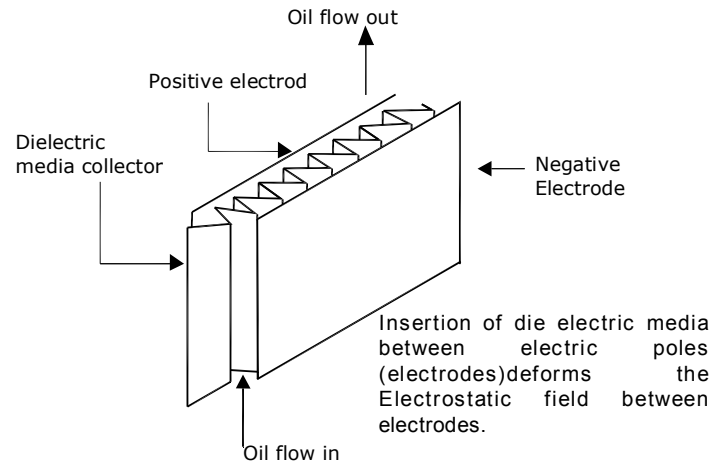

The neutral contaminations are also drawn and deposited by gradient force to the edge of the dielectric media, where the intensity of the deformed electric field is the highest.

Deformed electric field is strongest at the Edge of dielectric media hence maximum, Contamination get deposited at the, Pleated edge of collector (Dielectric media or filter paper)

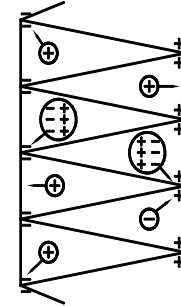

Mfg. by:- M/s. Ferrocare Machines.

Electrostatic liquid cleaner can remove all particles suspended in oil, which may be magnetic, non-magnetic, organic, inorganic, resinous matter or sludge, including virus and bacteria. Particles upto 0.01 micron can be removed. Cleaning ELC does not change viscosity, does not remove additives, and keeps the oil in running condition for very long time.

Websites of manufacturers:

- www.ferrocare.com
- www.hydrodyneindustries.com
- www.hydroline.com

5.28 Hose Break Valve

Hoses are widely used as fluid conductor in hydraulic machines. They are also used for very high pressure, and in critical machine such as Elevating platform, Forklift, Bridge-crane etc.

All the hoses have a limited life. They should be replaced after certain period. Other-wise they may fail in actual operation. If a hose breaks in machine like forklift, crane etc. it may cause severe accident and lose of property and life

To safe guard against such accidents, which occurs due to sudden break of fluid-line, a unit called “Hose-Break valve” is used. It allows oil flow for which it is calibrated, and as soon as flow rate increases, it stops the flow. For example, If valve is calibrated for maximum 50LPM flow rate and if flow exceeds 50LPM, than this valve will completely close the flow path of fluid and locks the actuator, cylinder or motor.

Construction: -

Hose-Break valve consist of a valve body with in-build valve seat, a closing element (poppet) and a spring as shown in sketch.

Valve body has threads on its outside diameter, so that it can be fitted directly into the oil port of cylinder.

Operation: -

1. Whenever oil flows through the valve, it offers some resistance to flow. Forces developed due to resistance to flow, acts on closing element and try to close it, while spring acts against it and try to force up the closing-element and keeps valve open.

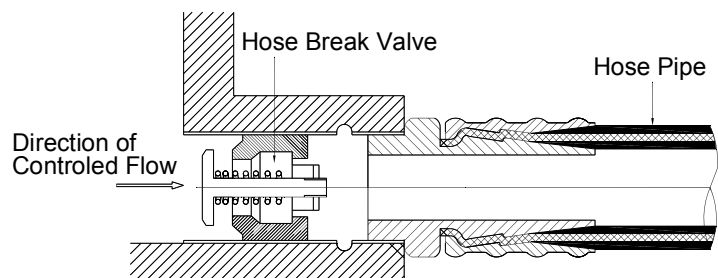
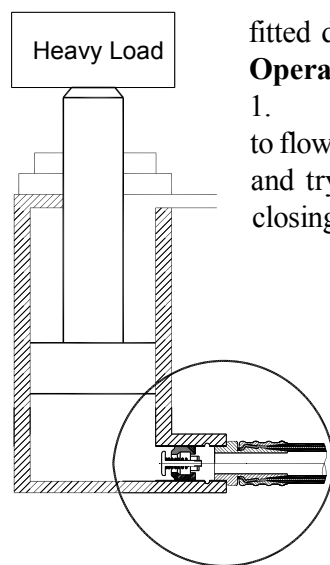
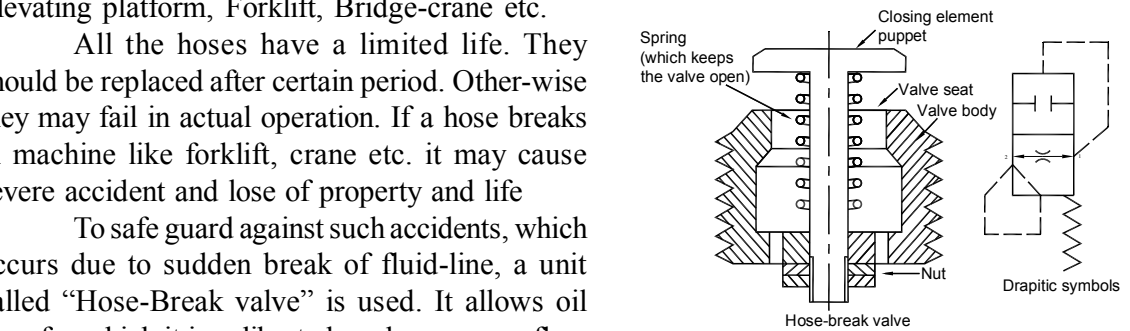

As flow increases the force developed due to resistance to flow also increases and when it overcomes spring force, it forces “closing-element” on valve seat and stop flow through the valve completely.

- To open the valve again pressure is applied in reverse direction, to lift the closing element.
- Valve is calibrated for 20% more flow, as small amount of flow fluctuation is common whenever the direction control valve is actuated. Also as temperature of oil drops, its velocity increases. More viscous oil exerts more closing force on valve, with same flow rate.
- This valve should not be used as switching valve for repeated closing action. It is also recommended that in case of hose failure, this valve should also be replaced along with the new hose.

Websites of manufacturers:

- www.hydacusa.com
- www.expoemirates.com
- www.fluidpress.it

5.29 Quick Connection Coupling

Some time hydraulic pipe lines have to be disconnected frequently. In such cases as soon as pipe lines are opened, hydraulic oil in pipe line drain out, as well as there are more chances of contamination entering in pipe line from open joint.

Opening of pipe line also takes time and physical effort. To solve this entire problem a special unit developed, which is called quick connection coupling. It can be opened in few seconds. It can seal both the ends of pipe joint as soon as it opens, and it is quick and effortless.

Cross-section of said Quick connection coupling is follow.

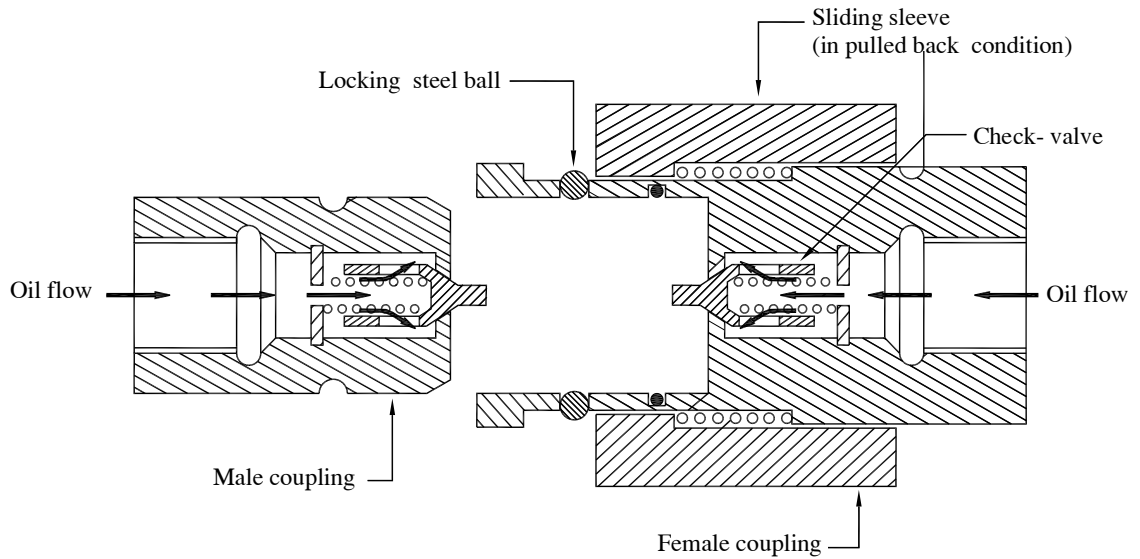

Quick-connection coupling

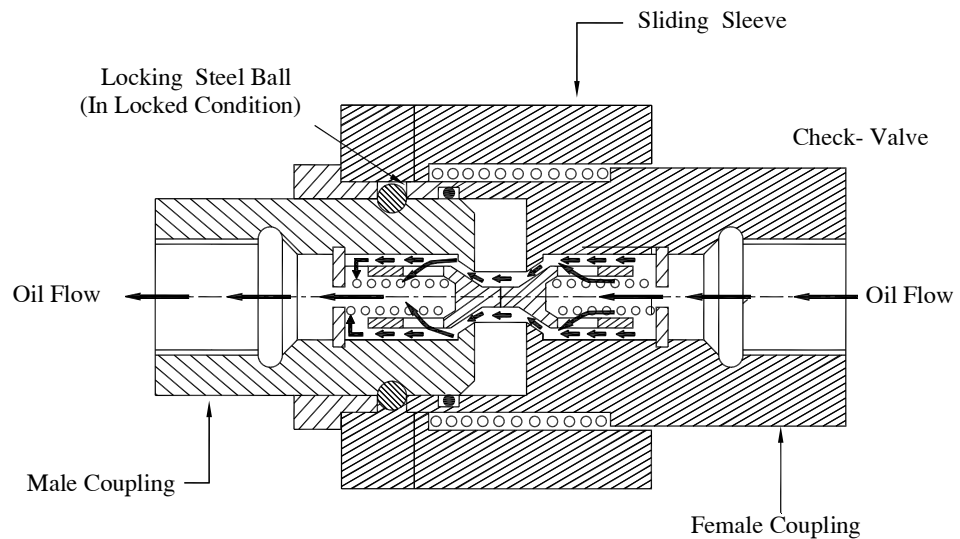

Quick - Connection Coupling

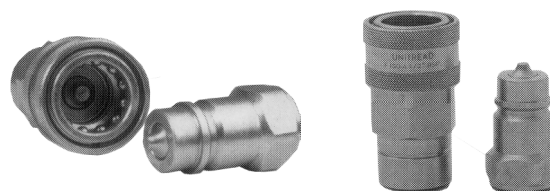

Mfg. by:- M/s. Unitread Hydraulics

Construction of Quick connection coupling:-

Quick connection coupling consist of two check valves. The poppet of check valve is of special shape with projected front portion. When male and female coupling are press against each other, the projected part of poppet of both male and female coupling presses back each other, and lift the poppet from it's seat, and make path for oil to flow.

To lock both the coupling in engaged condition, a spring loaded sliding sleeve and locking steel ball is used. Before engaging and disengaging the couplings, sleeve is pulled back, this allows steel ball to move in groove or out of groove. Once both couplings get engaged. The spring of sleeve force sleeve to slide forward and overlap steel ball, which locks the steel ball in groove , and both coupling remain engaged, For disengagement again sleeve is pulled back, and both coupling pulled apart.

5.30 Rotary Joints

Hydraulic system work at very high pressure. At this pressure even when complete Hydraulic system as well as actuators are stationary, then also stopping leakage from hydraulic fitting and joint is a big problem. When there is vibration or relative movement than this problem becomes more sever. By using hose pipe some defection is possible, but if continuous rotation is required then special rotary joint becomes necessary.

Rotary joints is a special accessory, which allow complete relative rotation between pipeline and actuator at high pressure. Such joints are specially required in application like hydraulic rotary chucks, in which it has to hydraulically hold the job, as well as rotates for machining operation.

Rotary joints thrust bearing and rotary seal between its various rotating parts to avoid leakage, as explained in following sketch.

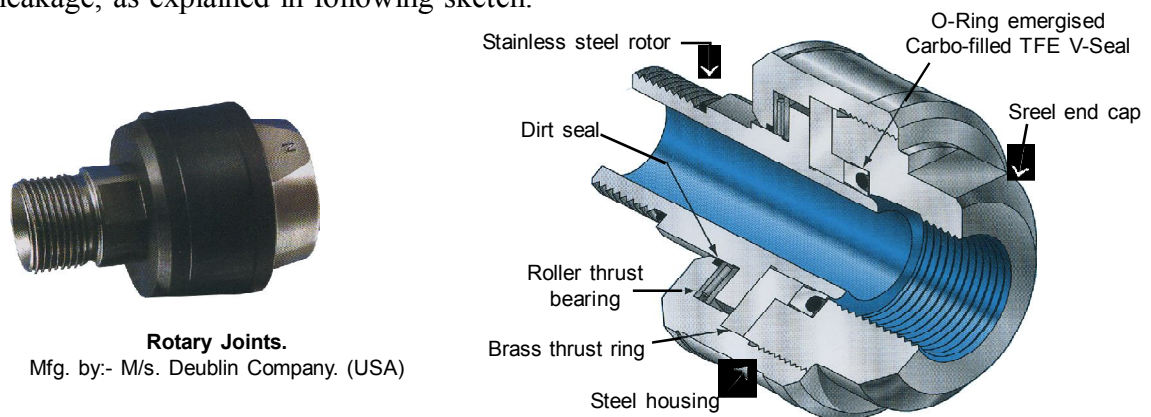

Rotary Joints.
Mfg. by:- M/s. Deublin Company. (USA)

Rotary Joints.
Mfg. by:- M/s. Deublin Company. (USA)

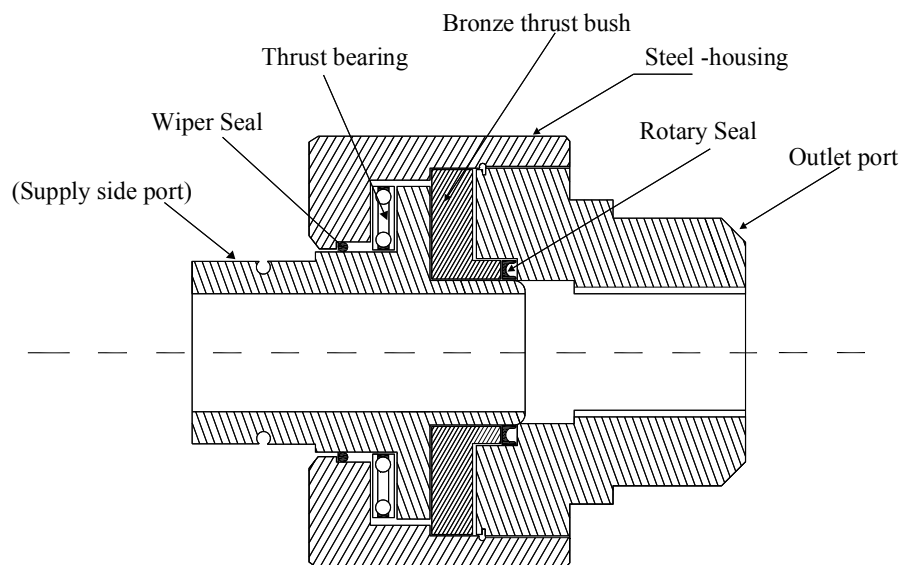

Under pressure rotary make the joint because leak proof. Because of oil pressure outlet side port and rotor end port will try to push each other a port. It is steel honing which holds than together. To outlet port side the unit by means stationery threading. And to Rotor end side it hold the unit in place through the thrust a bearing. With stand separation face acting on both units, as well as allows relative rotational motion.

Addresses or websites of manufacturers:

- www.deublin.com
- www.aiplen.com
- www.rotherm.com

5.31 Vibration Control Unit

Shearing presses, forging presses, and number of other hydraulic machines requires good foundation, because operation of these presses produces impact shock and vibrations. If special type of vibration control units are used, then foundation size could be reduced, leveling of machine could be done easily, and crack in building structure, and damage to near by sophisticated machines could be avoid.

These vibration units are designed and made specially for different application, using rubber, spring and hydraulic shock absorbed.

Some of the vibration control units are as follow:

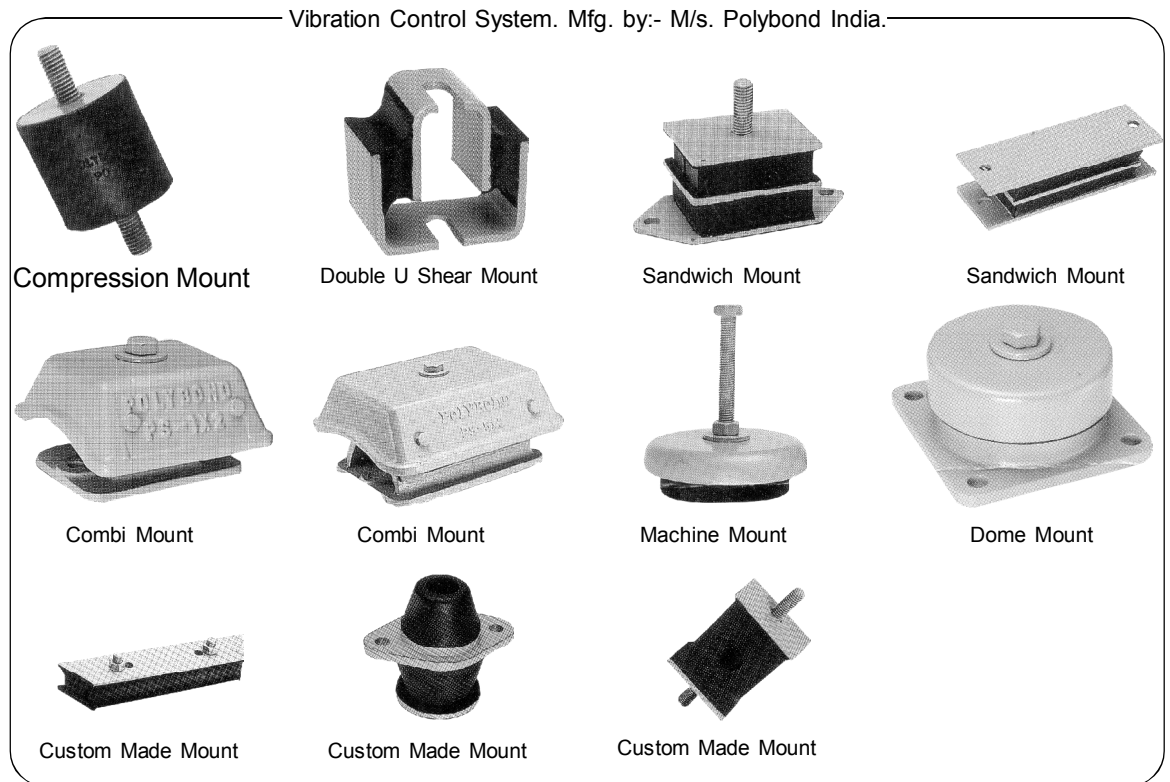
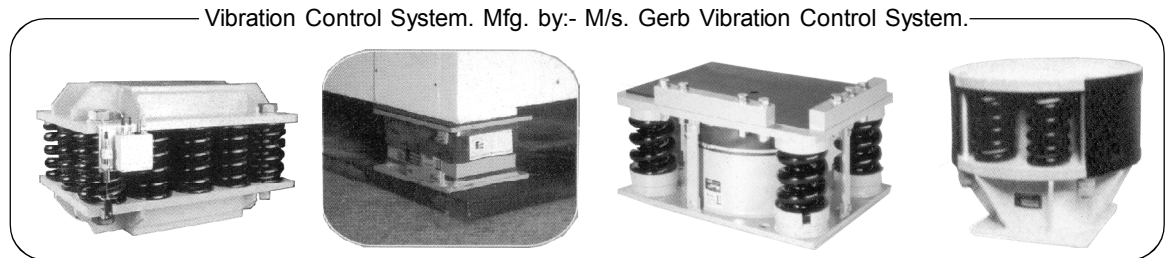
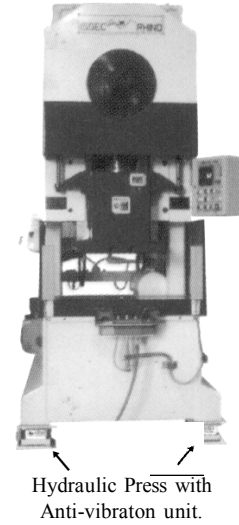

Website of manufacturers:

- www.gerb.com
- www.polybondindia.com

5.32 Anchor Bolt

Anchor bolts are used to fix hydraulic presses and power pack unit to the thick concrete flooring. Such bolt can not be used for forging presses and impact making machine. But for non-vibrating and smoothly running machines, these bolts saves lots of labour and time for fixing machine by conventional method of fixing machine on concret flooring, which requires making hole in ground, fixing foundation eye bolt in concrete as per centre distance of foundation bolt, concreting them, and waiting for seven days for curing of cement.

For fixing by anchor bolt, we drill hole in thick concrete flooring , we insert anchor bolts in hole, hammer centre pin to expand inserted end of anchor bolt in flooring. We fasten foundation plate of machine to anchor bolt by tightening nut. Hence within few hours, press could be held firmly on ground. Anchor bolt simplify fixing of hydraulic machine on foundation , hence are included it in list of accessories for hydraulic press.

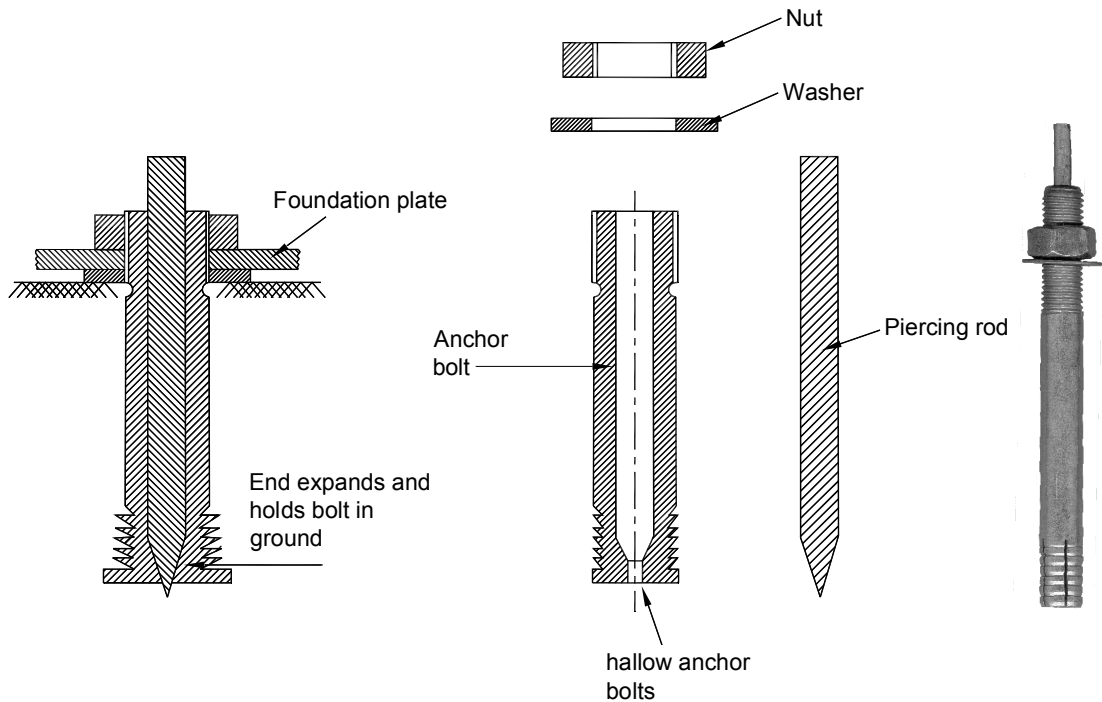

5.33 Cable Drag Chain

In case of material feeding systems which are hydraulically operated, long hoses, and cable has to move along with feeding attachment for long distance. For example feeding of rolled section in automatic shearing machine, for cutting at various length. As length of rolled section are approximately six meters, so material feeding arrangement has to clamp the rolled section, and keep on moving toward machine for six meters. Without any support or system, if hydraulic hoses and electrical cables are dragged for six meters, then they will get entangled, their protective coating will wear out, and after some period of time the complete system may collapse. Hence for neat, clean and systematic fixing of cable and hoses, and to protect them while dragging them to long distance, conveyers are used, which are generally called cable drag chain.

There are hundreds of types of cable drag chain, manufactured by various manufacturers for various operations. To have right conveyer chain, we should be clear about our requirements. Some of the data which a manufacturer ask us before supply of cable drag chain are as follow.

1) Inside dimension to accommodate hoses and cable.

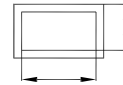

2) Out side dimension of conveyer to accommodate in machine system.

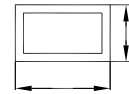

3) Minimum bend radius

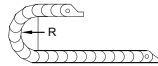

4) Unsupported length of conveyer .

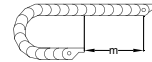

5) Weight on unsupported length.

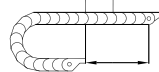

6) Distance to travelled.

7) Number of cables and hoses to be supported in side cable drag chain.



8) Fixing arrangement of hoses and cable with conveyer.

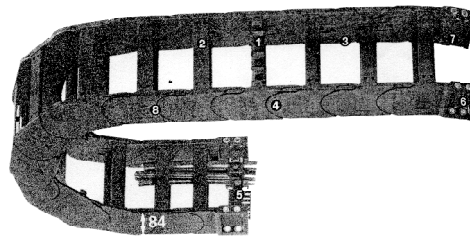

Horizontal Cable Drag Chain
Mfg. by:- M/s. Kumbhojkar Plastic Moulders

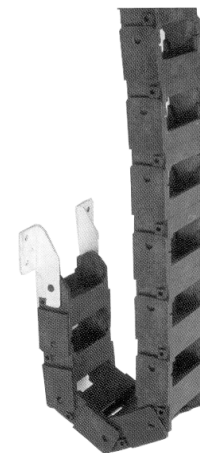

Vertical Cable Drag Chain
Mfg. by:- M/s. Kumbhojkar Plastic Moulders

Addresses or websites of manufacturers:

- www.plamoulds.com
- www.ignus.in
- www.kabelschlepp.de
- www.bharattextile.com/listings/sahmi-metal-industries.html

5.34 Hand-Pump

Hand pump is the first hydraulic unit developed centuries ago, and still it is one of the most important hydraulic unit used in industry. It is simplest and easiest equipment by which a high pressure fluid could be supplied. It basically consist of two check valves, a small cylinder and piston arrangement, and a lever with linkages to reciprocate the piston in cylinder.

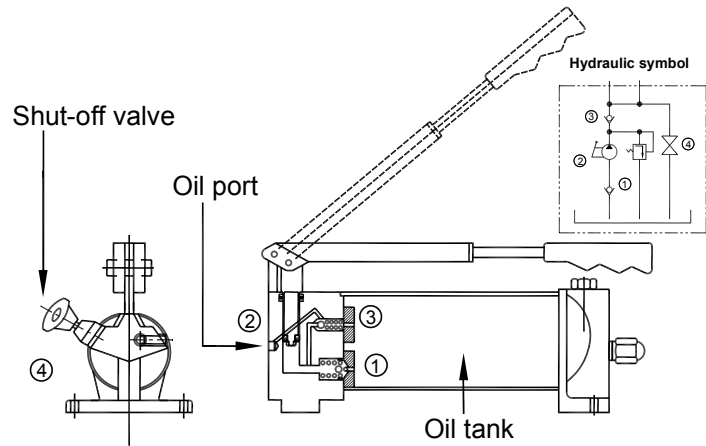

Dual discharge hand-pumps are manufactured for convenience in operation and to save production time. In dual discharge hand-pump, approximately 50 cc oil is delivered in one stroke, up to the working pressure of 30 bar. And when 30 bar pressure reaches, pump automatically changes over to smaller discharge per stroke. It may be 5 cc per stroke for pressure up to 350 bar and 2.5 cc per stroke for pressure up to 700 bar. This data is for hand-pump made by m/s. Polyhydron. Pressure and discharge per stroke may vary for other manufacturers.

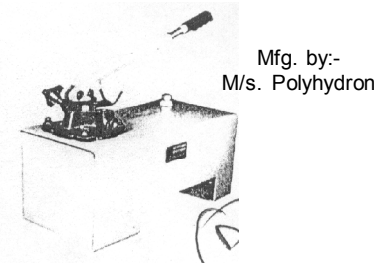
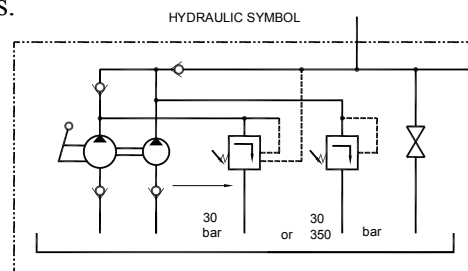

As technology progressed, hand pump also innovated and modified as per the requirement of industry. Few examples of use of hand pump are as follow:

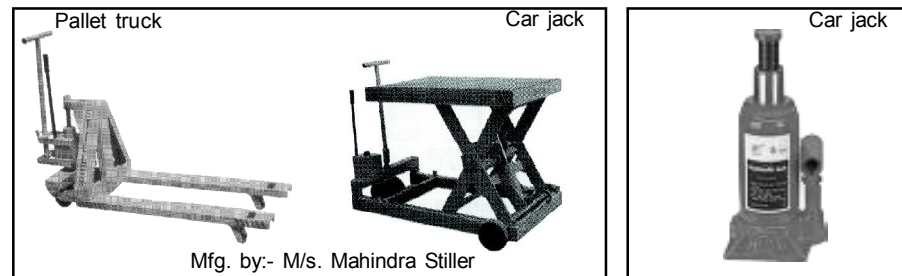

Websites of manufacturers:

- www.mahindrastiller.com
- www.americasprideonline.com
- www.polyhydron.com

5.35 Lubrication System

Piston and piston rod has sliding contact with cylinder and guide-bush, but they don't require external lubricant. Because hydraulic oil itself has lubrication properties. But except hydraulic cylinder, every sliding contacts in hydraulic machine should have good lubrication to have maintenance free long working life.

Some of the lubrication system available in industry are as follow:

1) Grease Gun:- This is simplest unit available for lubricating various joints. Basically it consist of a hand pump, which forces grease in sliding joints through a special small non-return valve type unit called Grease Nipple.

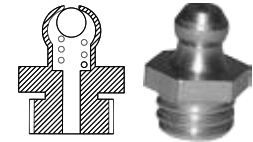

Grease Nipple Mfg. by:- www.rbrhw.com

High pressure lubricating pump:-

This unit is similar to grease gun, but grease gun is carried to various joints with grease nipple and grease is pumped in. While higher pressure lubricating pump is usually fixed to machine body, and grease is supplied to various joints through distribution block and pipe line. This unit develops pressure up to 300 bar.

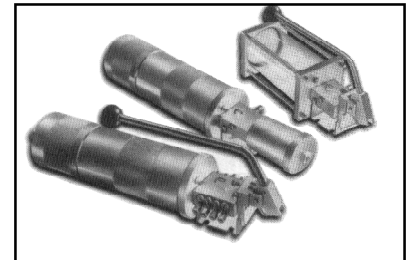

Motorised oil lubrication system:-

This unit is similar to a small power pack. These units are used for centralised lubrication system. These units works intermittently controlled by timer and discharges oil in joint through metering cartridge. Metering cartridge injects small quantity of oil in system.

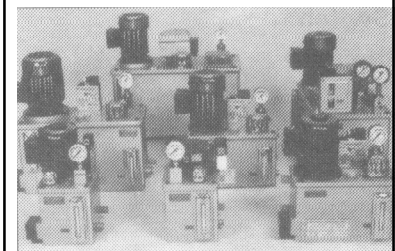

Low pressure hand / pneumatic pump:-

This unit is similar to hand-pump. But instead of grease this unit feeds oil in moving joints through metering cartridge. This unit could also be operated by pneumatic or hydraulic actuation.

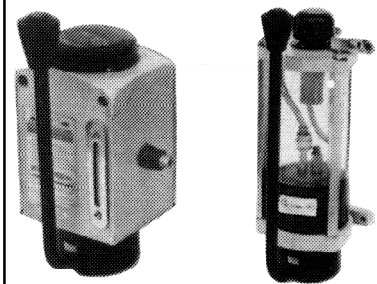

Mfg. by:- M/s. Systematrix
Engg. Services, Mumbai

For lubricating joint basically we use a hand-pump or small power pack. But success and effectiveness of lubrication depends more on distribution block and metering cartridge.

The internal working of Distributors:-

Distributors have no "Starting" or "Stopping" positions. Initially when all the pistons are on left hand side. Grease from inlet passage travel & connect to right hand end of piston A & B & Left hand end of piston C. There by making piston C move to right hand side (pull tab I) there by forcing the previous metered lubricant to outlet 1.

The change in position of plunger C close, some parts & open other. Hence grease moves to the left hand side (pull tab II) and forces the previous metered lubricant to outlet 2.

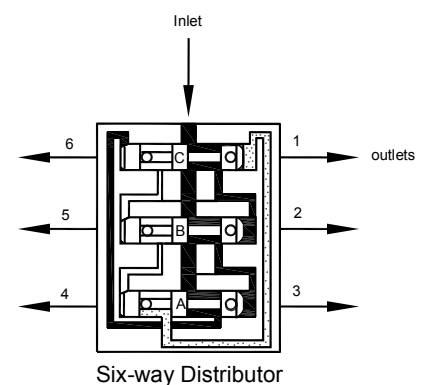

Note that no other plunger can move. i.e. only one plunger can move at a time, others remain locked, only on changing of direction does the other work. Hence this distributor are also called progressive distributor block.

After Piston B completes it's stroke from left to right, a similar connection to the left hand side of piston A moves in to the right hand side, forcing the metered quantity of lubricant to outlet 3. Here half the cycle is over as all plungers on the right hand side. From here on the whole process is repeated but in the other direction.

As long as the feed is given, the distributor block distributes lubricant in metered quantity progressively.

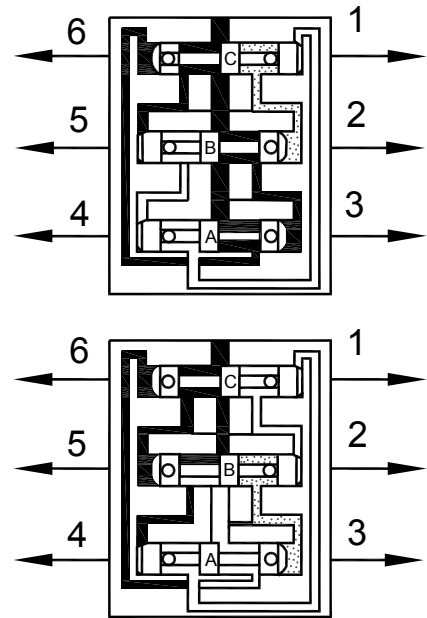

Metering Cartridges:-

These are valve which eject metered amount of oil to the each lubrication point. It requires recharging time of minimum 1 'minute between two cycles, An individual oil distributor is required for individual lubrication point in order to ensure the correct amount of lubricating oil is fed on lubrication point, oil distributor of correct dosage should be selected.

The guide line for selection of oil distributor with respect to lubrication area to be lubricated is given below :

1. Normal Condition

The Oil allocated for the lubrication point is in front of the piston in the distributor.

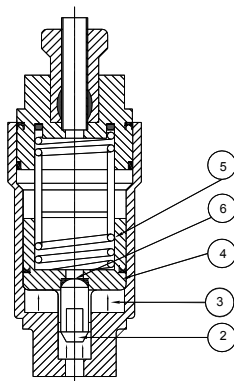

2. Discharge Condition

When Oil is fed by the centralised Lubrication pump, the oil pressures over the seal into the space, (2) Below the piston (4) and then the piston (5) moves up against the spring Force and discharges the oil lying in front of the piston into the system. The main line pressure 10-27 bar (minus the spring pressure) is the pressure which pushes the piston in the forward direction.

3. Refill Condition

On releasing the main line pressure (0.5-1 bar) the spring presses the piston down creation an

oil pressure, which expands the lip seal (2) which in turn seals the bore and opens the passage (6) oil then flows from below the piston through the passage (6) to the top of the piston till the stroke of the piston is completed. The passage (6) is again sealed and the distributor is ready for the next cycle.

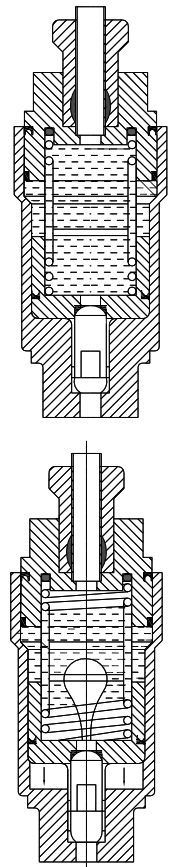

Websites of manufacturers:

- www.rbrhw.com • www.dropco.com
- www.systematrixengg.com

5.36 Rod End Bearing

Piston rod of hydraulic cylinders are designed either for tensile load or compressive load. They are not designed for side load or bending load. In clavis and trunnion mounting cylinder, end of piston rod is coupled with component to be pushed or pulled by a bush and pin arrangement for free rotational movement. The rotational movement of cylinder is suppose to be in one plane, but due to misalignment, over load., wear and tear, there is always a possibility of deflection of movement in second plane or direction. As cylinder is designed for movement in one plane, any deflection in second plane will cause stress and strain in piston rod and cylinder, which may damage it. Hence spherical bearings are fitted at the moving joints in place of simple bushing to absorb the minor deflection and misalignment.

As this is a regular requirement in industry , and good spherical bearing increases life of cylinder seal and life of piston rod. Hence various type of rod end bearing has been developed by many manufacturers and extensively used in industry. Some of them are as follow:

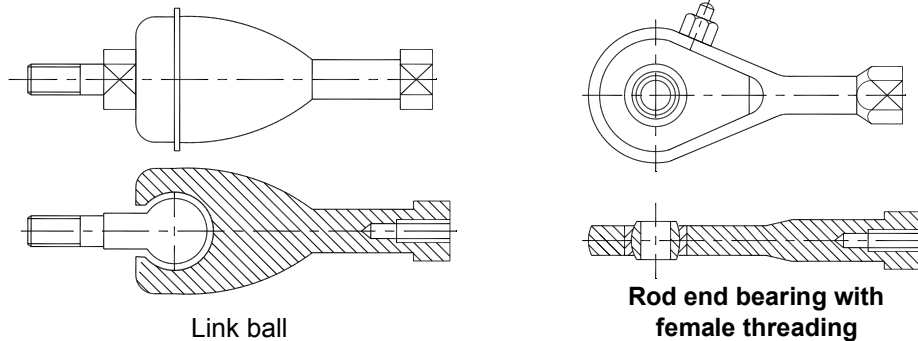
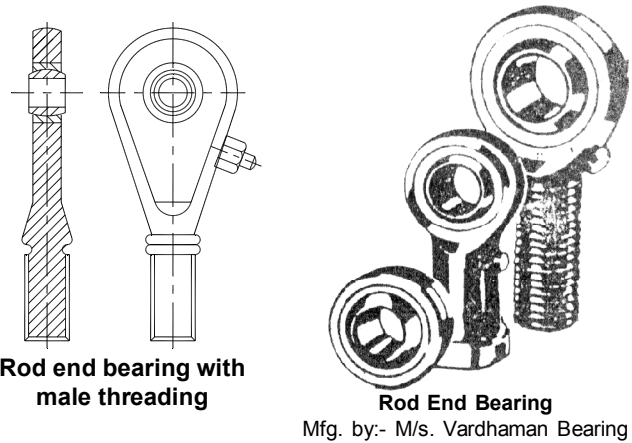

Addresses or websites of manufacturers:

- www.igus.de
- www.bellhydromatics.com
- www.vardhmanbearings.com

5.37 Flow Divider (Tendum Gear Pump Type)

Synchronising number of cylinder at a time is very difficult and costly affair. It require number of pressure compensated flow control valve, along with its piping, and manifold block.

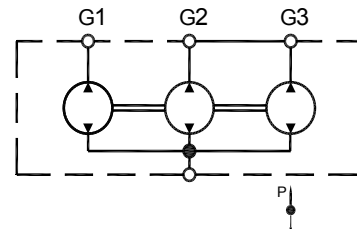
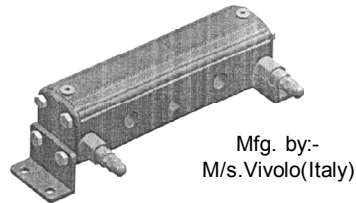

Diagram Of Divider Comprising Three Elements

Vivolo oleodinamica of Italy manufactures a compact tendum gear pump type flow divider, which can function as a flow divider, as pump and a motor. It can synchronise number of cylinders at a time, or at act as pump, or motor for all the cylinders or individual cylinder, depending upon the configuration of flow divider and hydraulic circuit.

This flow divider is not pressure compensated. When this unit is used for speed synchronisation, depending on load on each cylinder, there may be speed difference, and at end of stroke, some cylinder may extended more than other. To equalise all the strokes at the end, a phase correction valve is added (inbuilt), so that the fastest cylinder wait after completing stroke, till other cylinder complete their stroke. And in this waiting period the oil of fastest cylinder bypasses to tank via phase correction valve (which is basically a relief valve).

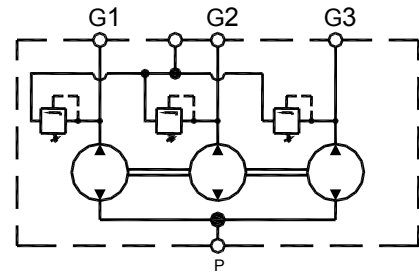

Diagram Of Three - Element Divider With Motor

When suction and delivery of last element isolated from others, then this unit can act as a pump or motor for other hydraulic circuit.

When oil under pressure is supplied at p1, and p2 connected to tank, than last element act as independent pump for any other circuit. And when pressurised oil supplied at p2, and

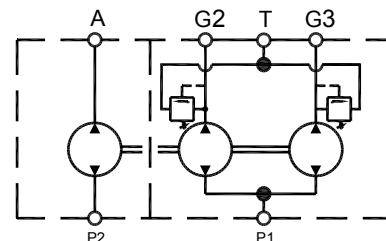

Diagram Of Two - Element Valve With Motor

p1 connected to tank, then last element works as motor for rotating shaft of remaining element, for drawing equal amount of oil from cylinders.

The application of said flow divider, we will study, in section of hydraulic circuit.

Section - C

ELECTRICAL ACCESSORIES

5.37 Pressure Switch

A pressure switch is a mechanical device which converts a pressure change into an electrical function. The pressure change might be measured as pressure, vacuum, or differential between two pressures input..

Pressure switch uses diaphragm, piston, or other pressure responsive sensor, coupled to the mechanical means to actuate a electrical switch.

A spool type of pressure switch consist of a valve body, a spool, spring and adjusting screw, assembled together as per following diagram.

Pressure to be sensed act against spring force. As pressure increases, it over-comes the spring force, and pushes the piston on one side. This cause actuation of electrical switch.



Mfg. by:- M/s. Hydrotechnik

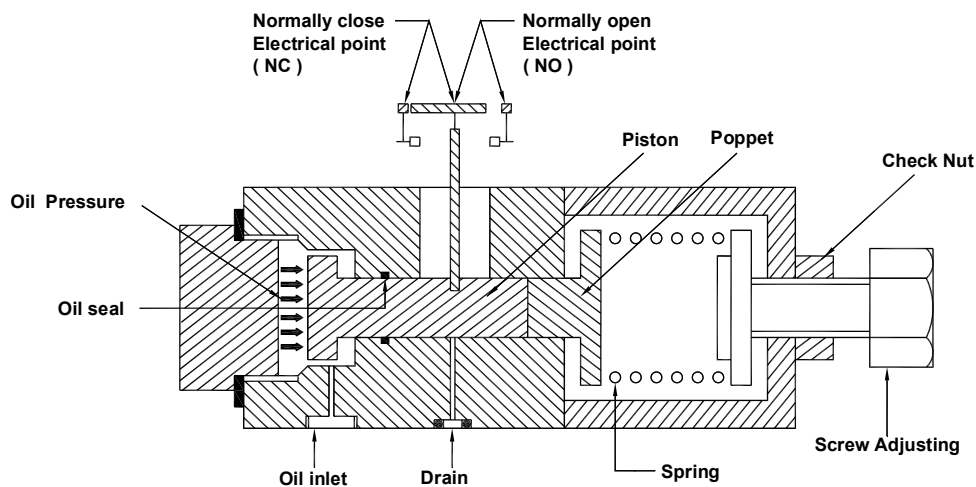

Pressure Switch (Skematic Diagram)

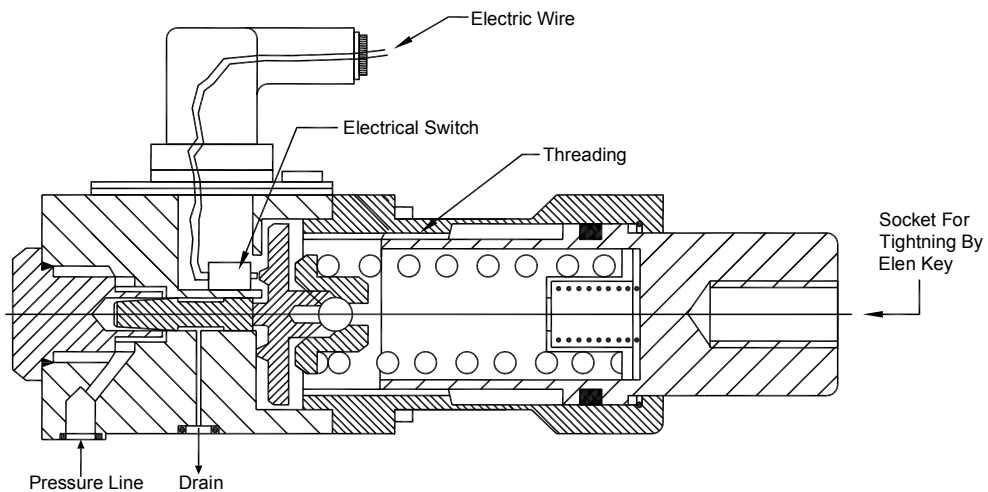

Cross Section of - Model _____ Presure Switch of M/S Polyhydron

Websites of manufacturers:-

- www.polyhydron.com
- www.hydrotechnik.com
- www.yukenindia.com
- www.rexroth.com
- www.eaton.com/EatonCom/ProductsServices/Vickers

5.38 Photoelectric Sensors

Many hydraulic presses are designed for very fast operation. In such presses a minor negligence of operator can cause fatal accident or hands of operator could get imputed. To avoid such accident initially electrically inter-locked mechanical guards were used. But opening and closing of mechanical guard wastes valuable production time. Hence nowadays electrical guards are used. In these guards, a series of photoelectric switches of “Through scan type” is used to sense the unwanted object in working area of hydraulic press. And if it is found, then it stops the press. Hence unless operator withdraw his hands and instrument, press will not work. These sensors are also called light safety curtain or infra-red barrier.

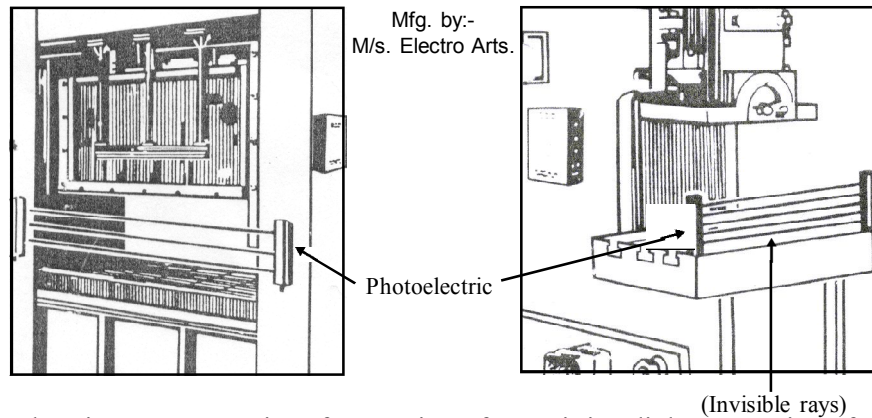

A photoelectric sensor consists of an emitter for emitting light, a receiver for receiving light. When emitted light is interrupted or reflected by the sensing object, it changes the amount of light that arrives at the receiver. The receiver detects this change and converts it to an electrical output which is generally 10 mA current (Max). This output current is sensed and processed by control panel for next operation.

Photoelectric switches could be used in three ways

1) Through scan:- Here the transmitter and receiver are housed separately and are positioned on either side of the monitored object(s).

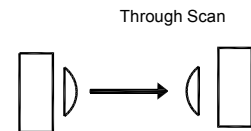

2) Retroreflection scan:- A reflection is used here to direct beam from transmitter to receiver, both of which are housed together. This type is specially designed for applications where space is at a premium.

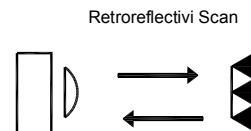

3) Diffuse scan-The monitored object is used here to divert the beam from the transmitter to the receiver. This type can be conveniently used as a proximity switch.

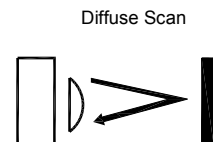

Infrared photoelectric switches are made in different shapes and sizes, few of them are as follow:

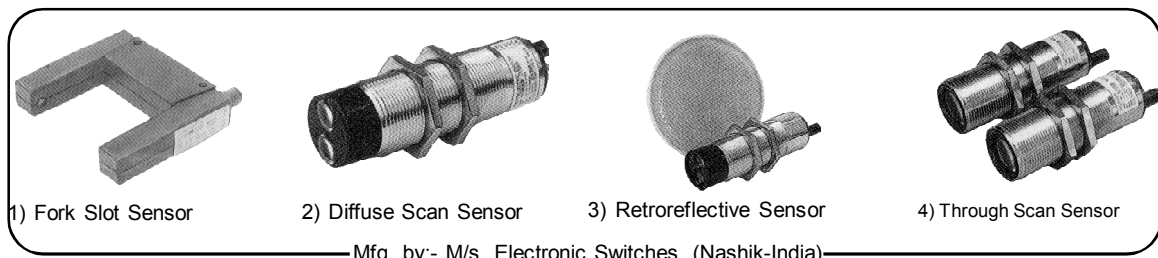

Websites of manufacturers :-

- www.electronicswitchesindia.com
- www.electroarts.org

5.39 Limit Switches

This electrical accessory is used in hydraulic presses to sense the stroke of cylinder, or movement or position of a moving part.

Limit switches basically consist of a electric switch, a mechanism to actual said switch, and a aluminium housing or encloser.

When a moving part passes close to the limit switch, it physically actuates it. This actuation cause changing over of contacts in electrical switch in-side casing of limit switch. Change of contact may be from NC (Normally close) to NO (Normally open) or NO to NC, or both if two elements are used inside. This change over of electrical contact gives signal in control panel for next operation of process cycle.

Different types of limit switches designed in industry to suit different requiremments. The detail of which could be studies from their catalogue or websites.

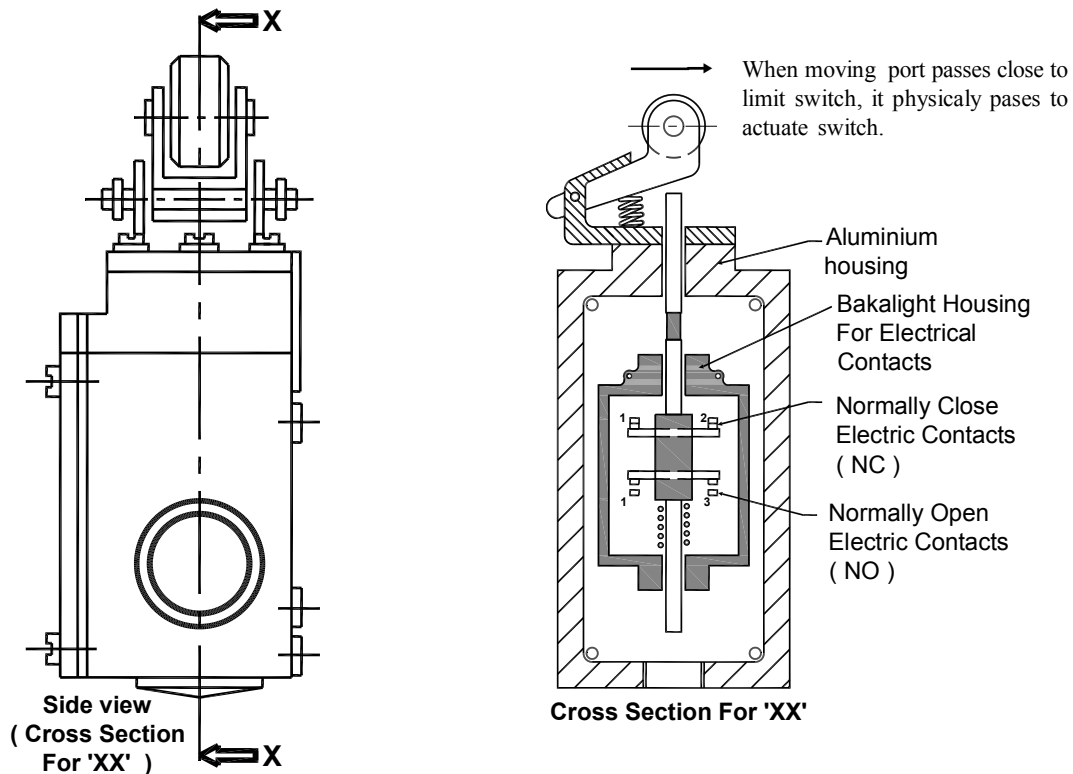

Websites of Manufacturers :-

- www.pewa.panasonic.com
- www.proximity-sensor-switches.com
- www.parasproximity.com
- www.technik.com

5.40 Pendent switches

Pendent switch is basically a electric push button. We are including it in important list of electrical accessories, because in some presses like dishing press, bending press, straightening press, by using pendent switch, operator can stand at long distance from press at convenient place, look at material to be pressed and operate press. He can take forward-reverse strokes of cylinder conveniently at his will to press component as per requirement. This drastically improves the productivity and efficiency of system.

Pendent switch consist of a encloser, spring loaded knob, and a electrical element, which could be selected as 'Normally Open' (NO) or 'Normally Close' (NC) type depending on requirement of control panel.

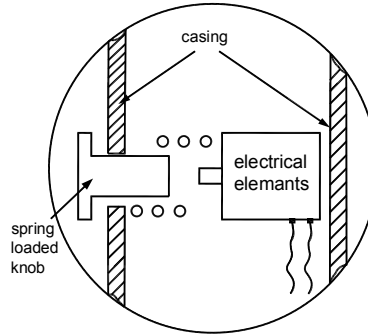

Mfg. by:- M/s.
Kumbhojkar Plastic Moulders, Pune

Websites of manufacturer:-

- www.plamoulds.com
- www.nema.org
- www.mcjillelectrical.com

5.41 Proximity Switches

This electrical accessory is similar to limit switches, but it get actuated without physical contact. It works on principle of induction. The distance of sensing may be from 1mm to 5mm (depending on design). It get actuated without physical contact, and changes over contact from NO to NC or NC to NO. It has only one contact that is either NO or NC. Proximity switches are also available AC as well as DC voltage.

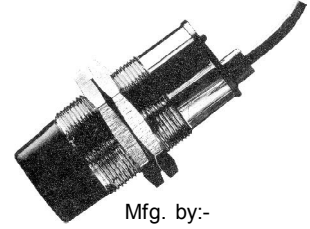

Mfg. by:-
M/s. Accent Controls, Thane.

Websites of Manufacturers :-

- www.accentsensors.com

5.42 Foot Operated Switches

This electrical accessory is used in hydraulic press, where the operator, operate press (gives actuation signal) by his foot instead of his hand.

For example in hose-crimping machine, operator holds the hose in his hand between crimping jaws and operate machine by foot switch. In punching and marking press, operator holds the component in hand and operate machine by foot switch.

Hence foot operated switch is one of the important electrical accessory, which reduces the additional man-power, and increases the productivity of operator.

Foot operated switch is also similar to limit switches. It consist of aluminium housing or encloser, an electrical switch or element, and a mechanism to actuate electrical switch by foot.

Different types of foot operated switches available in market are as follow.

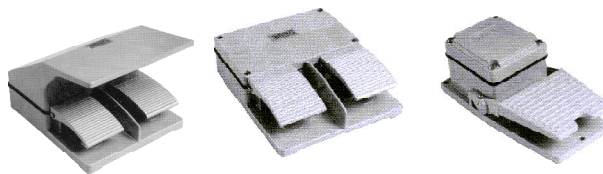

Mfg. by:- M/s. Precision Engg.

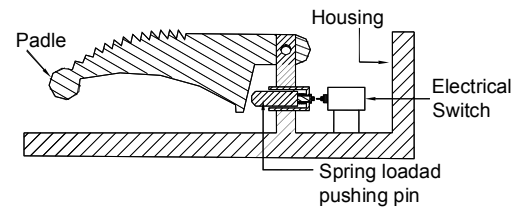

Cross-section of foot operated switches

Websites of manufacturers:-

- www.brisk.co.in
- www.kinesis-ergo.com
- www.footswitch.co.in

5.43 Pressure Transducers

The input for most instrumentation system is nonelectrical. In order to use electrical methods and technics for measurement, the nonelectrical quantity is converted into a proportional electrical signal by a device called “Transducer.”

Transducers can also be defined as a device that performs the initial measurement and energy conversion of a process parameter into analogous electrical information.

Another definition of Transducer is that, it is a device which when actuated by energy in one system, supplies energy in the same form or in another form to a second system.

When transducer gives output in electrical form it is known as electrical transducer.

Most pressure transducer consist of some form of deflectable or deformable element that serves as the primary transducer. Deflection of this element is measured by a secondary transducer, and the measurement is translated electronically into a pressure recording. Secondary transducer may be a strain gauge, or a LVDT, or a inductive or capacitive strain transducers.

In following example a foil type diaphragm strain gauge is bounded to the stem of bending shaft, and supplied with a stabilised voltage between 5 to 10V. DC, it produces an electrical output signal which varies from 1 to 1.5 mv / volt.

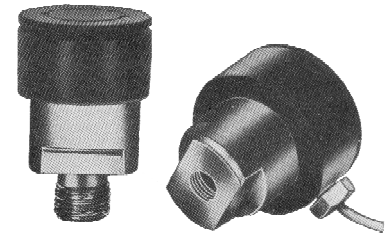
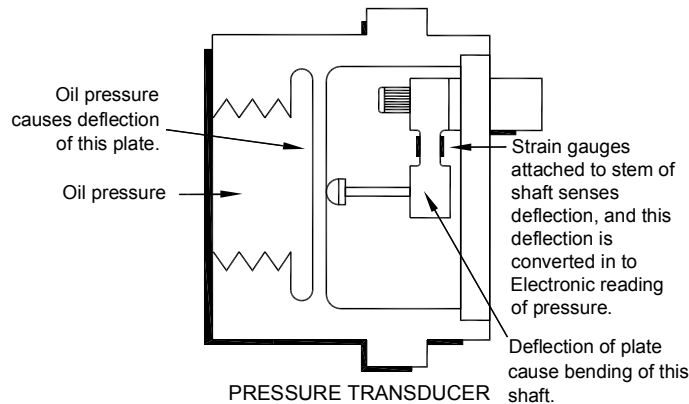

Precision Electronic Pressure Transducers
Model- PC-94,
Mfg. by:-M/s. Hytech Micro Measurement.

For very high pressure measurement, high pressure transducer uses gold-chromium wire as shown in following diagram. Resistance of wire changes with change in hydrostatic pressure. This principle is utilised for measuring the pressure.

Wire is enclosed in a bellow, filled with kerosene. Hydraulic fluid compresses the bellow, because of which, pressure of kerosene increases. Increase in kerosene pressure causes change in the resistance of wire. The changes in resistance is measured and converted to read the pressure.

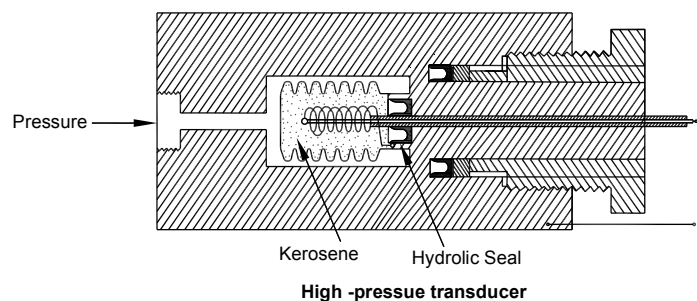

(Reference book: :Measurement system, application & designing” by- Ernest O Doebelin, Mc Crew Hill Publishing Co.)

Transmitters:- Transducers gives signal in form of few millivolt or milli ampere. This small signal may be too small to be sensed or actuate next operation in control panel. Hence by another electronic circuit they are amplified to such an extent that they could be used in PLC or CNC control panel. When a transducer has an in-built amplifying circuit, then that unit is called as transmitters. For example pressure transmitters, Temperature transmitters etc

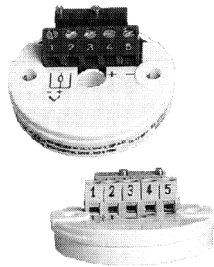

Temperature Transmitter
Mfg. by:-

M/s. Waaree Instruments, Mumbai



Pressure Transmitters

Model:- 221C-Series
Mfg. by:-

M/s. Waaree Instruments, Mumbai

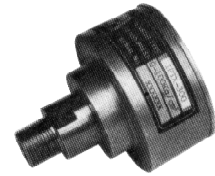

Pressure Transmitters

Model:- PTX-300XX-Series

Mfg. by:- M/s. Instrument Research Association.

Sensor :- A sensor is a device that produces a measurable response to a change in a physical condition, such as temperature or thermal conductivity, or to a change in a chemical concentration. In hydraulic machines, sensor is used to measure temperature of oil etc.

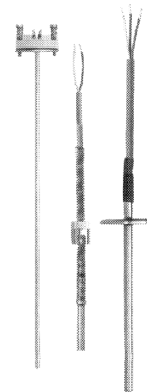

Temperature Sensor

Mfg. by:-
M/s. Waaree
Instruments, Mumbai

Thermocouples:- A thermocouple consists of a pair of dissimilar metal wires joined together at one end, forming the sensing, or hot junction, and terminated at the other end which is known as reference or cold junction, cold junction is maintained at a known constant temperature (reference temperature). When a temperature difference exists between the sensing junction and the reference junction, an emf is produced. The magnitude of this voltage depends on the wire used, and the temperature difference between two junctions. In hydraulic press thermocouple is used to sense the temperature of heated platen.

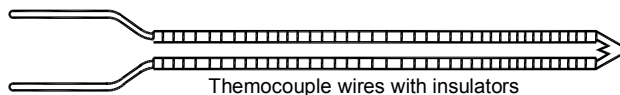
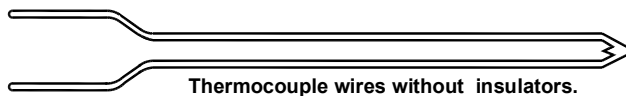

Mfg. by:-
M/s. Waaree
Instruments,
Mumbai

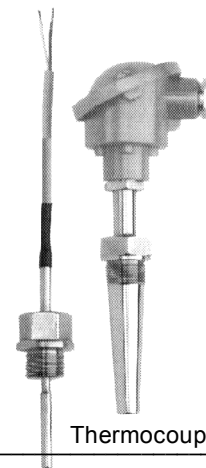

Thermocouples

Websites of manufacturers:-

- www.waaree.com
- www.ssntonline.com
- www.hytechmicro.com
- www.waaree.com
- www.irainstrumentation.com
- www.omega.com
- www.ajaysensors.com
- www.kobold.com

5.44 Digital Read Out or DRO

The resistance of a metal conductor is expressed by

$$R = \rho \frac{L}{A}$$

Where R = Resistance Ω

A = Cross section area of conductor (m^2)

L = Length of conductor (m)

ρ = Resistivity of conductor (Ωm)

The resistance of metal changes if length of conductor changes, or if conductor is strained, or if conductor changes.

Potentiometer is a electrical resistance transducer, which measures linear or rotational displacement by measuring changes in resistance due to change in length of conductor. Load cells or pressure transducer uses strain gauge, in which change in resistance is due to change in strain in electrical conductor, which is caused by application of pressure or force.

In temperature transducer, changes in resistance is measured , which is due to change in temperature in conductor.

For measuring change in resistance of conductor, an AC or DC current is continuously passed through conductor, and resistance is continuously measured by switchable electronic circuit and instrument. Any change in resistance is sensed and converted in suitable form to indicate the change in parameter which is to be measured.

A potentiometer consist of very thin wire of 0.01 mm diameter of platinum or nickel alloy, and carefully wound on an insulator (cermet, carbon or other metals are also used), and a sliding contact. Sliding contact is called wiper. The motion of sliding contact on resistive element may be transitory or rotational.

When wiper slides on resistive wire the length of effective length of resistive wire changes, resulting in changing of total resistance of conductor. This change is measured and converted suitably to read visually or converted in to electrical signal to actuate any other electronic instrument.

The instrument which is used to visually read the reading of movement is called Digital Read Out or DRO. Linear potentiometer and DRO is widely used in hydraulic press to read stroke of cylinder.

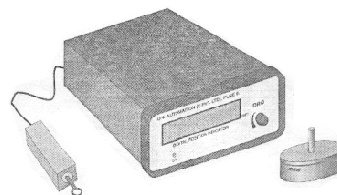

Digital Read Out (DRO)

Mfg. by:-

M/s. Uni-Automation India

5.45 Linear Variable Differential Transducer (LVDT)

The most widely used inductive transducer to convert linear motion into electrical signal is the linear variable differential transducer (LVDT). The construction of LVDT is as per fig. No. ____ . It consist of a primary winding P. Two secondary winding S_1 and S_2 placed on both the sides of primary winding. All the three windings ate circular in shape. Wound on a cylindrical formor. At the centre of circular coil a movable soft iron core is placed.

Secondary windings have equal number of turns and are identically placed on either side of the primary winding. The primary winding is connected to an AC current, with frequency of 50 Hz to 20 KHz. The AC current produces an alternating magnetic field, which in turn induces alternating current (AC) voltage in the two secondary windings.

The output voltage of secondary S_1 and S_2 are E_{S1} and E_{S2} respectively. In order to convert the output from S_1 and S_2 in to a single voltage signal, the two secondary windings S_1 and S_2 are connected in series opposition as shown in fig. ____ . Thus the output voltage of the transducer is the difference of the two voltage.

Differential output voltage = $E_0 = E_{S1} - E_{S2}$

When the core is at central position which is also called null position, the flux of both the secondary windings are equal , hence equal emfs are induced in them. Hence at null position $E_{S1} = E_{S2}$ and $E_0 = E_{S1} - E_{S2} = 0$

If core moves to left or right the flux linked to that side secondary winding increases and other side decreases, so the difference of E_{S1} and E_{S2} increases .

This difference of E_{S1} and E_{S2} indicates the extent of shifting of iron core from centre. Iron core is connected to the component whose movement is to be measure. And change of voltage E_0 indicates the extent of movement. This voltage is converted and processed suitably to visually read the displacement and to actuate another electrical instrument. LVDT gives good result from few micron to maximum displacement of 5 mm.

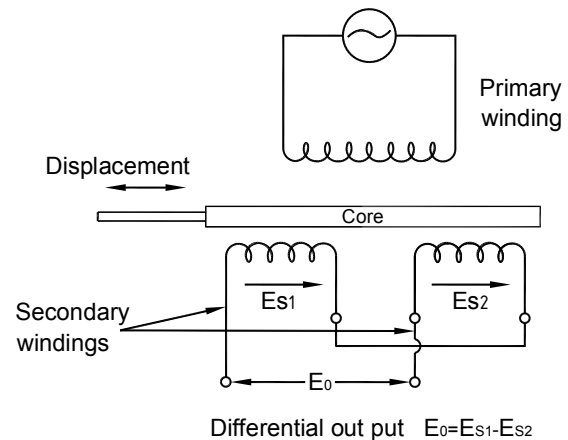
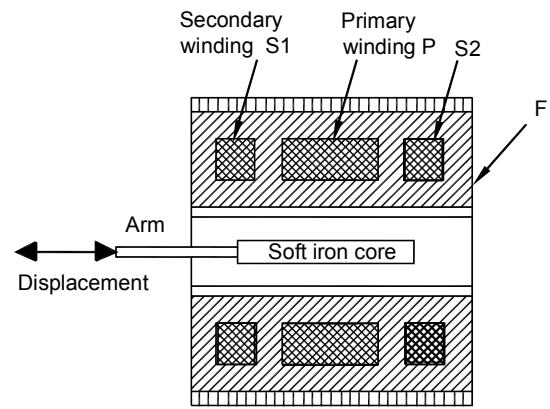

Mfg. by:-
M/s. Hommel Etamic GmbH

5.46 Potentiometer

The resistance of a metal conductor is expressed by

$$R = \rho \frac{L}{A}$$

Where R = Resistance Ω

A = Cross section area of conductor (m^2)

L = Length of conductor (m)

ρ = Resistivity of conductor (Ωm)

The resistance of metal changes if length of conductor changes, or if conductor is strained, or if temperature of conductor changes.

Potentiometer is a electrical resistance transducer, which measures linear or rotational displacement by measuring changes in resistance due to change in length of conductor. Load cells or pressure transducer uses strain gauge, in which change in resistance is due to change in strain in electrical conductor, which is caused by application of pressure or force.

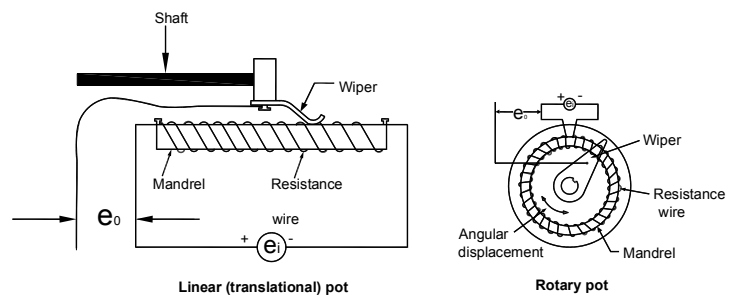

In temperature transducer, changes in resistance is measured , which is due to change in temperature of conductor.

For measuring change in resistance of conductor, an AC or DC current is continuously passed through conductor, and resistance is continuously measured by suitable electronic circuit and instrument. Any change in resistance is sensed and converted in suitable form to indicate the change in parameter which is to be measured.

A potentiometer consist of very thin wire of 0.01 mm diameter of platinum or nickel alloy, and carefully wound on an insulator (cermet, carbon or other metals are also used), and a sliding contact. Sliding contact is called wiper. The motion of sliding contact on resistive element may be transitory or rotational.

When wiper slides on resistive wire the length of effective length of resistive wire changes, resulting in changing of total resistance of conductor. This change is measured and converted suitably visual reading or converted in to electrical signal to actuate any other electronic instrument.

The instrument which is used to visually read the reading of movement is called Digital Read Out or DRO. Linear potentiometer and DRO is widely used in hydraulic press to read and control stroke of cylinder.

Dimension and technical details of potentiometer manufactured by M/s. Uni-automation is as follow:



Linear Motion Slide

Mfg. by:- Holmark Slides & Controls

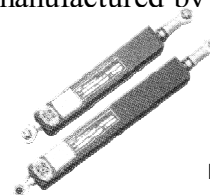

Potentiometer

Mfg. by:-

M/s. Orbital Systems, Mumbai

Websites of manufacturer:-

- www.uniautomation.com
- www.holmarc.com
- www.orbitalsystems.net

Linear Motion Transducers:-

Many Hydraulic machines and presses requires exact positioning of components under process. For example, plate sharing ,machine requires quick and precise setting of back mark for cutting plate precisely as per required length. Similarly plate punching machines, press brake etc. all require precise position of component.

Reading the position of a component and controlling, correcting and positioning through electric circuit is possible with help of a position transducer. This transducer moves along the moving parts, and provides electrical analog signal proportional to the position of moving part. Output signal may be voltage or current. For long distance travel which may be from 50 to 1200 mm, a potentiometer is used, and for short distance travel from fraction of a millimeter to few centimeters, linear variable differential transformer (LVDT) is used.

5.47 Load Cells

Cross section of hydraulic cylinder are multiplied by working pressure, is equal to force developed by cylinder. But what we calculate theoretically may not be available on the work piece, may due to friction between moving part of the press, pressure drop in hydraulic line, unreliable pressure gauge etc.

In mass production if we get final product as per our specification , with in safe capacity machine, then we don't care about the exact force at which we get our production. But in case of calibration of machine in it's initial stage of trial and assembly, or for any requirement where exact force developed by press or tank or cylinder is to be calculated, estimated or cross-checked , then electronic gadgets are used which can precisely indicate load or force developed.

Load cell is one of the most important unit used for this purpose. It works on principle of strain gauge, and gives output signal in form of voltage or current, using electronic current said output signal is converted directly into unit of force and can be viewed on LCD screen.

Various types of load cell designed for various application are as follow.

Mfg. by:- M/s. Atco Sensors, Mumbai

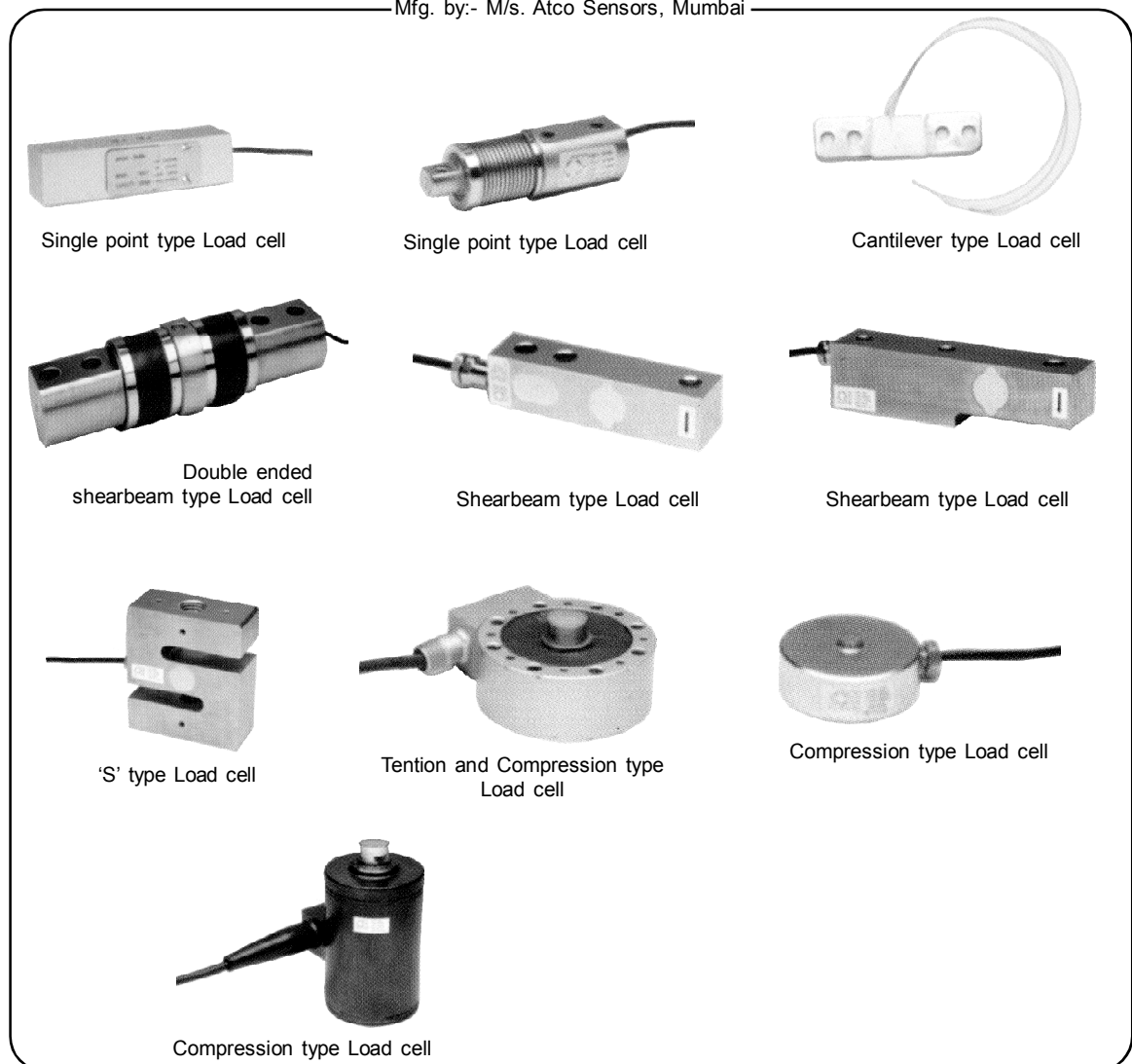

Website of manufacturer:-
• www.atco-industries.com

5.48 Programmable Logic Control (PLC)

Refer to the chapter of hydraulic circuit diagram, section ____, in which we described the sequence of operation of deep drawing press.

Conventional electrical control panel could be made to have sequence of operation as per requirement. But in such control panel the sequence of operation, which we have decided before making and wiring of control panel can not be changed afterward. For any change, wiring of control panel has to be changed accordingly.

- To solve this problem, programmable Logic Control (PLC) has been designed and developed.
- In PLC we can store 99 or more programs, and in each program we can have different sequences of operation.
- Without having a physical timer in control panel, we can make a program, in which we can decide time of each operation. (Delay time, curing time etc.)
- PLCs are designed to have many input and output signals, it many ranges from few to more than 100 signals.
- PLC has a central processing unit, similar to what calculator or computer do have. A monitor or screen which is like calculator. A key-board similar to calculator. Provision to connect it to computer for selecting or changing program, and provision to feed input signal and receive out put signal.
- PLC can have in-built counter.
- While using PLC, we do have all the sensors and control units in machine, such as limit switches, pressure switches, proximity switches, temperature sensor and controller, encoder, photo-sensor, solenoid valves etc.
- We also have conventional control panel with contactors to supply rated voltage and current to various electrical units, such as solenoid valves, heater, cooler, starter for motor etc.
- Through output signal and small relays PLC control the contactors and relays of connected load such as contactors of motor starter, contactors of solenoid valve etc. And by controlling sequence of the actuation of these contactors and relays PLC control over all functioning of control panel and machine.

A photograph of PLC and details provided by its manufacturer are as follow:

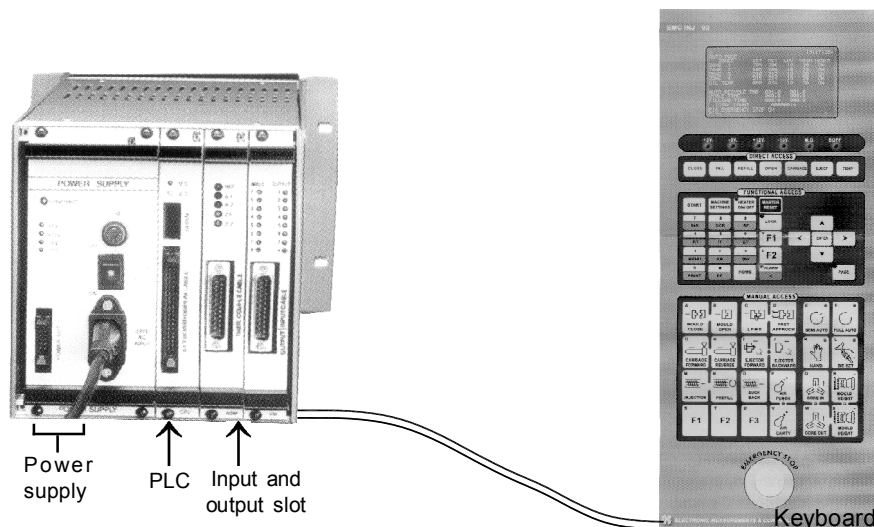

Skematic Diagram of PLC

1) Power is supplied to PLC through SMPS (switch main power supply) as we do for computer. Generally it is DC 24 volt. AC 230 is also available, but 24 DC volt has many advantages over AC.

2) Central processing unit is called PLC. Key board and display which look like calculator is called display or key board. Both may be independent unit or integral. As per DIN standard PLC unit is designed and manufactured in a standard pattern, which is called modular design, in which if we start from left, first we have SMPS or power supply unit, then we have central processing unit or PLC, then we have provision for input and output. In input we have provision for connection of wire from push-button, limit switch, temperature and pressure sensor etc. This section of module is also called digital input.

3) Modular design also has provision for output connection. But electrical actuators could not be directly connected to PLC, because volt and amount of current supply by PLC may not be sufficient to actuate them. Hence all the output of PLC is connected to a bunch of relays, and these relays are connected to load. Bunch of relays are called “relay card”. These relays are designed to actuate the load, such as contactors etc.

Program is written and fed through display or key board. This unit is connected to PLC by wire. As per program designed and fed with the help of key board. PLC carry out sequence of actuation and operation, and display unit keeps on displaying, the status of operation under process.

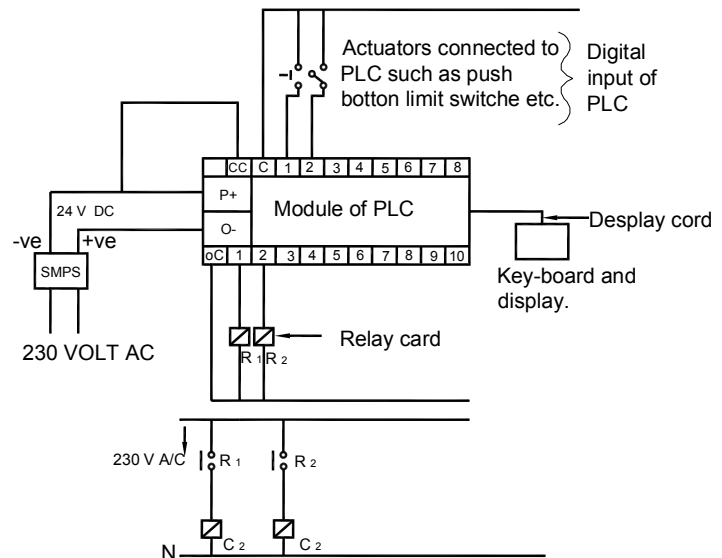

Numeric Control (NC)

- Numeric control was basically used in machine tool for producing large quantity of standard identical, precisely machined component. Numeric Control (NC) minimise or eliminate the involvement of machine operator for mass production.
- It consist of punched tape or magnetic tape which is encoded with control or command for machine for producing a component as per a particular drawing. As drawing or component changes, punched tape of manufacturing component also changes.

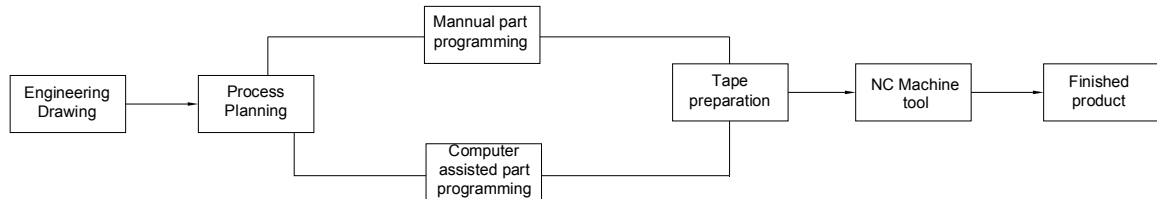

The procedure of production through Numerical Control.

Computrised Numerical Control (CNC) :-

CNC machines are advance model of NC machine.

- In case of Computrised numerical control, a computer is attached to machine. Instead of feeding punched card (as in case of NC machine) a program can directly be feed to machine by key-board.

Number of program could be stored in memory of computer.

- Computer also has diagnostic software which enables easy trouble shooting, if CNC system malfunctions.

- The valves and components used in CNC machines are proportional or servo control type, with feed-back arrangement. Hence computer constantly monitor the output of machine and in case of deviation from standard parameter. It modifies the input signal to match the output parameter as per standard or reference parameter.

CNC is advance stage of PLC. It also replaces the fixed hand-wired function. It has programmable flexible function with addition of self diagnostic and correcting feature through servo valves and components.

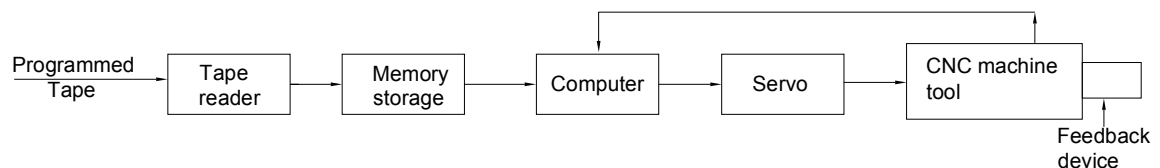

The procedure of production through Computrised Numerical Control (CNC)

Thermo Switches

Oil cooler and heaters are used in power pack unit to regulate temperature of oil in optimum range.

To actuate cooler or heater first temperature is sensed by thermocouple, then through control panel either main motor is stopped to avoid over-heating or cooler or heater is actuated for cooling or heating.

M/s. FCH Olaer Group has developed a compact electrical unit, which directly actuates the heater or cooler depending on temperature without using control panel or contactors.

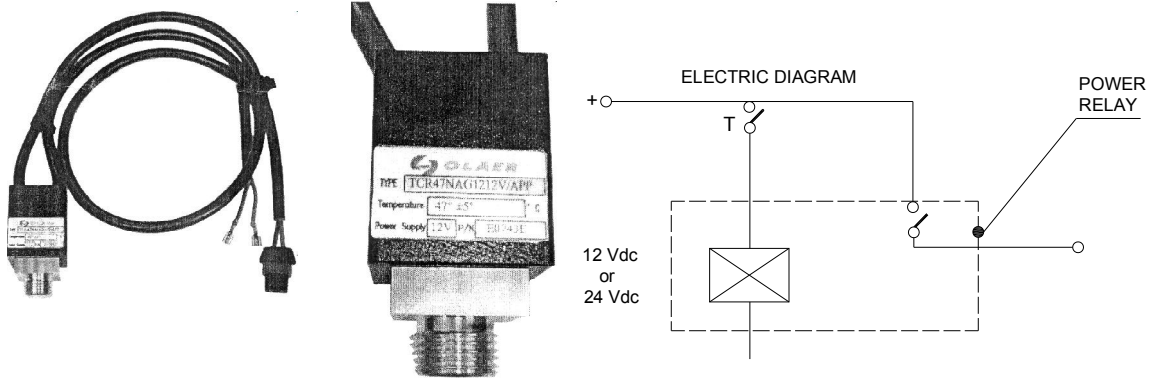

Thermo Switches Mfg. by M/s. FCH Olaer Group