

INTRODUCTION TO HYDRAULIC PRESSES

Q.S. Khan

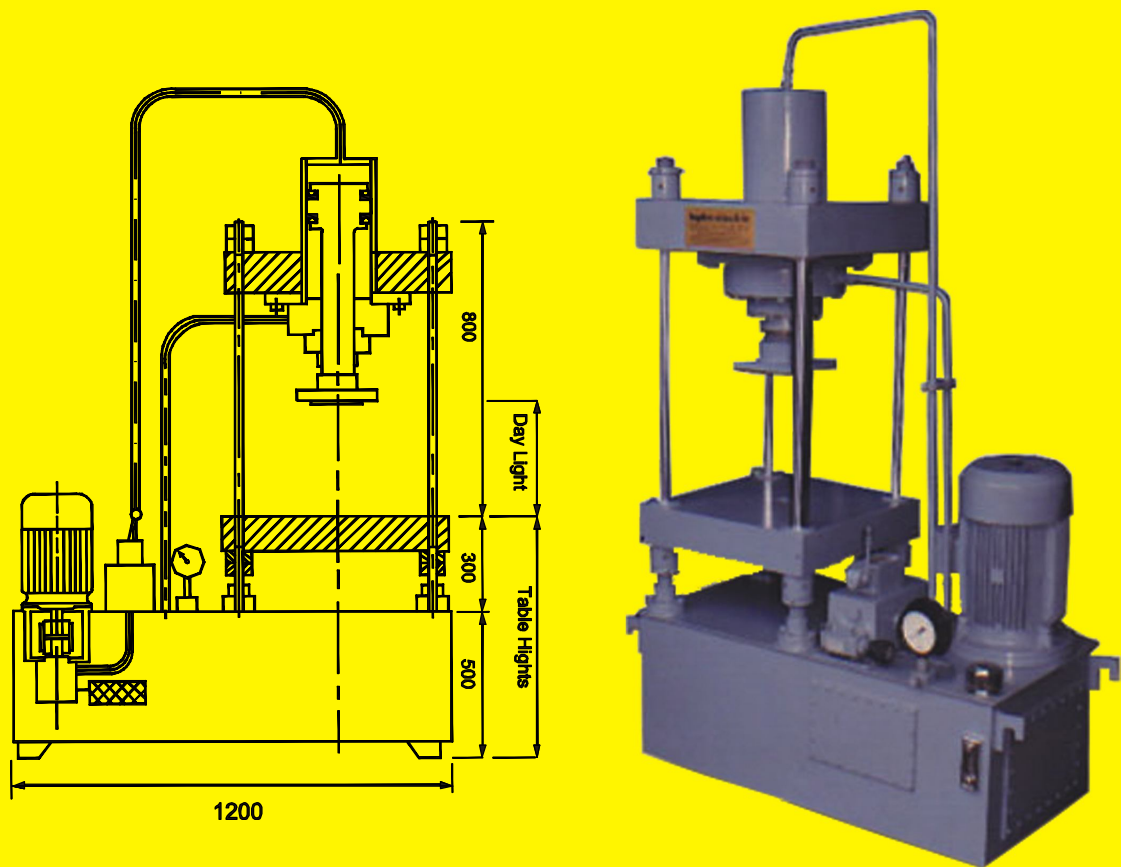

TANVEER PUBLICATIONS

Hydro Electric Machinery Primises
A/12, Ram-Rahim Udyog Nagar, LBS Marg, Sonapur,
Bhandup (W), Mumbai - 400078

INTRODUCTION TO HYDRAULIC PRESSES

Q.S. Khan

(B.E. Mech.)

TANVEER PUBLICATIONS

HYDRO-ELECTRIC MACHINERY PREMISES

12-A, Ram-Rahim Uduog Nagar, Bus Stop Lane, L.B.S. Marg,
Sonapur, Bhandup (west), Mumbai - 400 078 (India)

E-mail: hydelect@vsnl.com

INDEX

1.	Introduction to Hydraulic Presses	5
1.1	Main Cylinder	6
1.2	Blank Holding Cylinder	6
1.3	Ejector Cylinder	6
1.4	Top Platen	6
1.5	Bottom Platen	6
1.6	Moving Platen (Pressing Platen)	6
1.7	Column, Nut and Check-Nut	6
1.8	Guides	6
1.9	Press-Table	6
1.10	Power-Pack Units	6
1.11	Control Panel	6
1.12	Manifold Blocks and Hydraulic Pipings	7
1.13	Ram, Piston -Rod	7
2.	Terms Related to Hydraulic Presses	9
2.1	I.D. of the Cylinder	9
2.2	Ram (Piston Rod) Diameter	9
2.3	Day-Light	9
2.4	Shut Height	9
2.5	Stroke of Cylinder	9
2.6	Table Size	9
2.7	Distance between Columns	9
2.8	Throat Distance	9
2.9	Table Height	9
2.10	Overall Size of Press	9
2.11	Weight of Press	9
2.12	Oil-Tank Size	9
2.13	Pressing Capacity	9
2.14	Working Pressure	10
2.15	Maximum Pressure	10
2.16	Speed of Ram	10
2.17	Cycle Time	10
2.18	Mode of Operation	10
3.	Terms Related to Feature of Hydraulic Presses	12
3.1	Press with Double Action Cylinder	12
3.2	Press with Single Action Cylinder	12
3.3	Press with Regenerative Circuit	13
3.4	Press with two Working Speed	13
3.5	Press with Pressure-Compensation Feature	13
3.6	Press with De-Compression Feature	13
3.7	Press with Pre-Stressed Column	13
3.8	Press with Cution Cynder, Ejector Cylinder, Blank Holding Cylinder, Auxiliary Cylinder	14
3.9	Verticle Press	14

3.10	Horizontle Press	14
3.11	Up-Stroke Press	14
3.12	Down-Stroke Press	15
3.13	Single Day-Light Press	15
3.14	Multi Day-Light Press	15
4.	Classification of Hydraulic Presses	16
4.1	Round Column Press	16
4.1.1	Tow Column Press	16
4.1.2	Three Column Press	17
4.1.3	Four Column Press	17
4.2	Fabricated Column Press	17
4.2.1	Four Column Press	18
4.2.2	Two Column Press	18
4.3	C-Frame Press	18
4.4	Close Frame Press	19
4.5	Fabricated Chamber Press	20
5.	Design Of Press-Body	21
5.1	Bending Stress	21
5.2	Fatigue and Endurance Limit	23
5.3	Selection of Type of Construction of Hydraulic Press-Body	23
5.4	Vertical-Plate type of Construction	23
5.5	Box-Section type of Construction	24
5.6	I-Section type of Press-Body Construction	25
5.7	Single Solid-Plate Type of Construction	26
5.8	Design of Press-Body with Vertical Plate Type of Costruction	26
5.9	Design Procedure	27
5.10	Design of Cylinder Mounting Plate (Plate No. 3)	30
5.11	Design of Column Supporting Plates (Plate No. 4)	31
5.12	Design of Re-Inforcement Ribs (Plate No. 5)	31
5.13	Design of I-Section Type of Construction	32

1.1 INTRODUCTION TO HYDRAULIC PRESSES

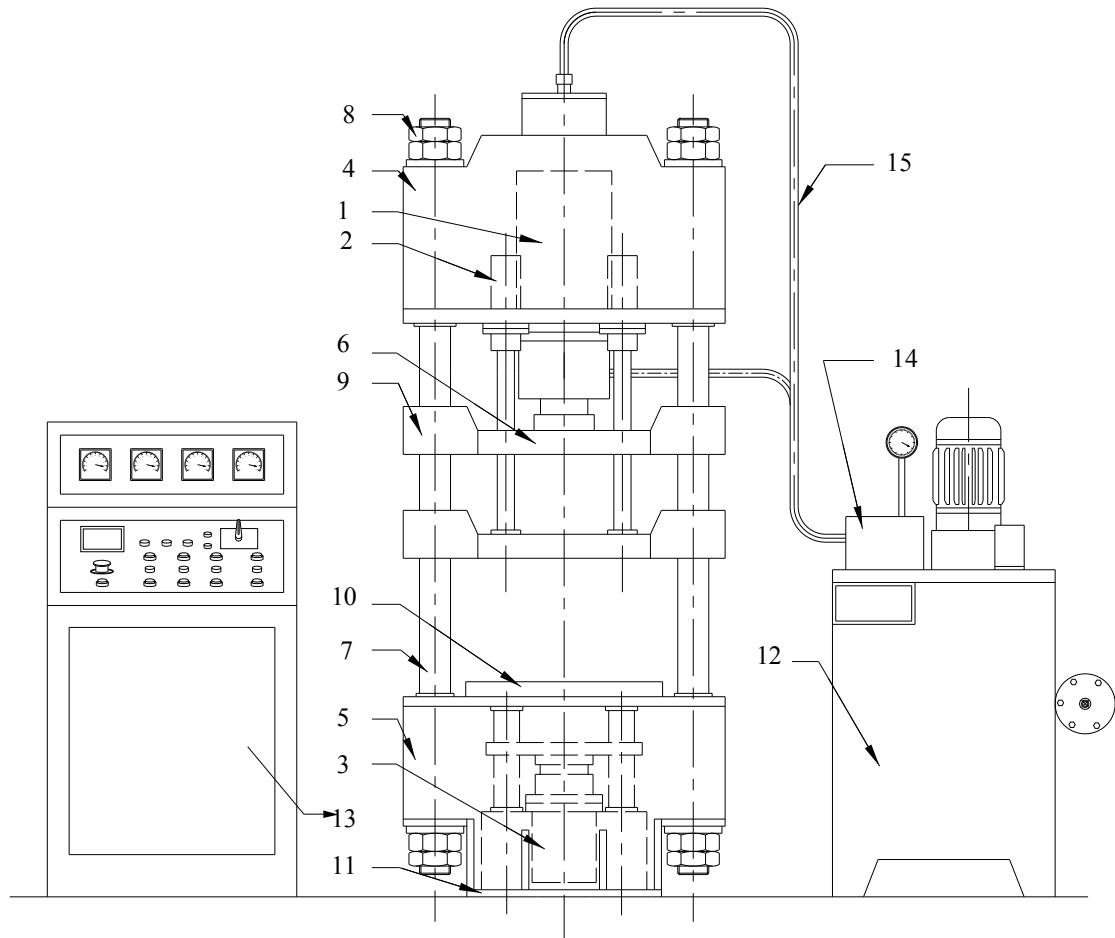

FIGURE NO.1.1, HYDRUALIC PRESS

- | | |
|--------------------------------|------------------------------|
| (1) Main Cylinder | (9) Side Guides (for column) |
| (2) Blank Holding Cylinder | (10) Press-Table |
| (3) Ejector Cylinder | (11) Foundation Plate |
| (4) Top Platen/Top Cylinder | (12) Power Pack Unit |
| (5) Bottom Platen/Bottom Frame | (13) Control Panel |
| (6) Moving Platen | (14) Manifold Block |
| (7) Column Pillars | (15) Hydraulic Piping |
| (8) Nut & Check-Nuts | |

1.1 Main Cylinder: -

Main cylinder is the most important part of a hydraulic press. Cylinder develops pushing or pulling force required to carry out desired operation, using pressurized hydraulic fluid.

1.2 Blank Holding Cylinder: -

Blank holding cylinders are used in those hydraulic presses in which raw material which is to be press must be held firmly in position, at the time of pressing operation by main cylinder. for example in deep drawing press , blank is held by block holding cylinder at the time of deep Drawing operation.

1.3 Ejector Cylinder: -

These hydraulic cylinders are usually mounted bellow the bottom platen, and used to eject component which are already pressed by main cylinder, and requires some force to get removed from die in which they got pressed. For example pressed component stuck in die after cold forming ejected by ejector cylinder.

1.4 Top Platen: -

Top platen is a steel fabricated or steel cast structure located upper side of a vertical press, and withstand compressive and bending load developed by hydraulic cylinder.

1.5 Bottom Platen: -

Bottom platen is a steel fabricated or steel cast structure located lower side of a vertical hydraulic press, and withstand compressive and bending load developed by hydraulic cylinder. It also used as a press-table in down-stroke presses.

1.6 Moving Platen [Pressing Platen]:

Moving platen is also a steel fabricated or cast structure. Locate between main hydraulic cylinder and pressing table. It is attached to Ram of cylinder and guided by side columns of press. Moving platen exert

force on the job placed on press-table.

1.7 Column, Nut & Chuck-nut: -

Columns are round Bar or fabricated structure. It binds top and bottom platen together firmly. Round bars are threaded at ends and nuts are provided to hold platen in position check- nuts are provided to avoid loosening of main nuts.

1.8 Guides: -

Guides are provided to ensure perfect parallel and vibration free movement of moving platen. Guides may be Round, V-Type, or flat, depending upon use and type of columns.

1.9 Press-Table: -

Press-Table is a thick steel plate either integral part of bottom platen or separately bolted to it. It is perfectly machined and provided with T-slots or tapped holes for mounting of dies and fixtures. Moving platen attached to ram travel forward and exert force on jobs placed on this press-table to carry out the pressing operation.

1.10 Power Pack Units: -

This is most important part of machine. It pumps oil under control pressure and flow into the cylinder to impart it desired speed and to develop desire force. Power pack consists of hydraulic valves, pump, oil tank, cooler, hydraulic accessories, manifold block and piping etc. Hydraulic pump may be driven by electric motor or I.C. engine.

1.11 Control Panel: -

It controls overall operation and performance of hydraulic press, by controlling power pack unit. It consists of motor starter, push-button, indicating lamp, current and voltage indicator, contactor, timer etc. Control panel gets it feedback from hydraulic press by means of limit switch, pressure switch, proximity-switch, thermo couple etc.

1.12 Manifold Block and Hydraulic Piping: -

Every hydraulic valves and pumps has number of oil port [holes] such as suction port, delivery port, tank line [return line] port, drain line port, pilot line port, oil port [A] for forward motion of cylinder, oil port [B] for return motion of cylinder etc.

All these ports [oil holes] should be inter-connected with each other, as well as with oil tank and hydraulic cylinder in correct manner and sequence for correct operation and motion of press. These inter-connection of various hydraulic component by means of special seamless steel pipe and special end-connection fittings are called hydraulic piping.

To reduce extensive piping, leakage and maintenance, hydraulic valves are mounted on a solid metal block, and their oil ports are inter connected by drilling holes in metal block. This solid drilled metal block is called manifold block.

1.13 Ram, Piston-rod: -

Piston-rod is a round bar, which is attached to piston, and moves in and out from cylinder for pushing and pulling operation. For small diameter it is called, piston - rod. When diameter of piston-rod is same as cylinder inside diameter, then piston-rod is called as Ram. But in general all the piston-rod of higher diameter is called ram.

1.2 TERMS RELATED TO HYRAULIC PRESSES

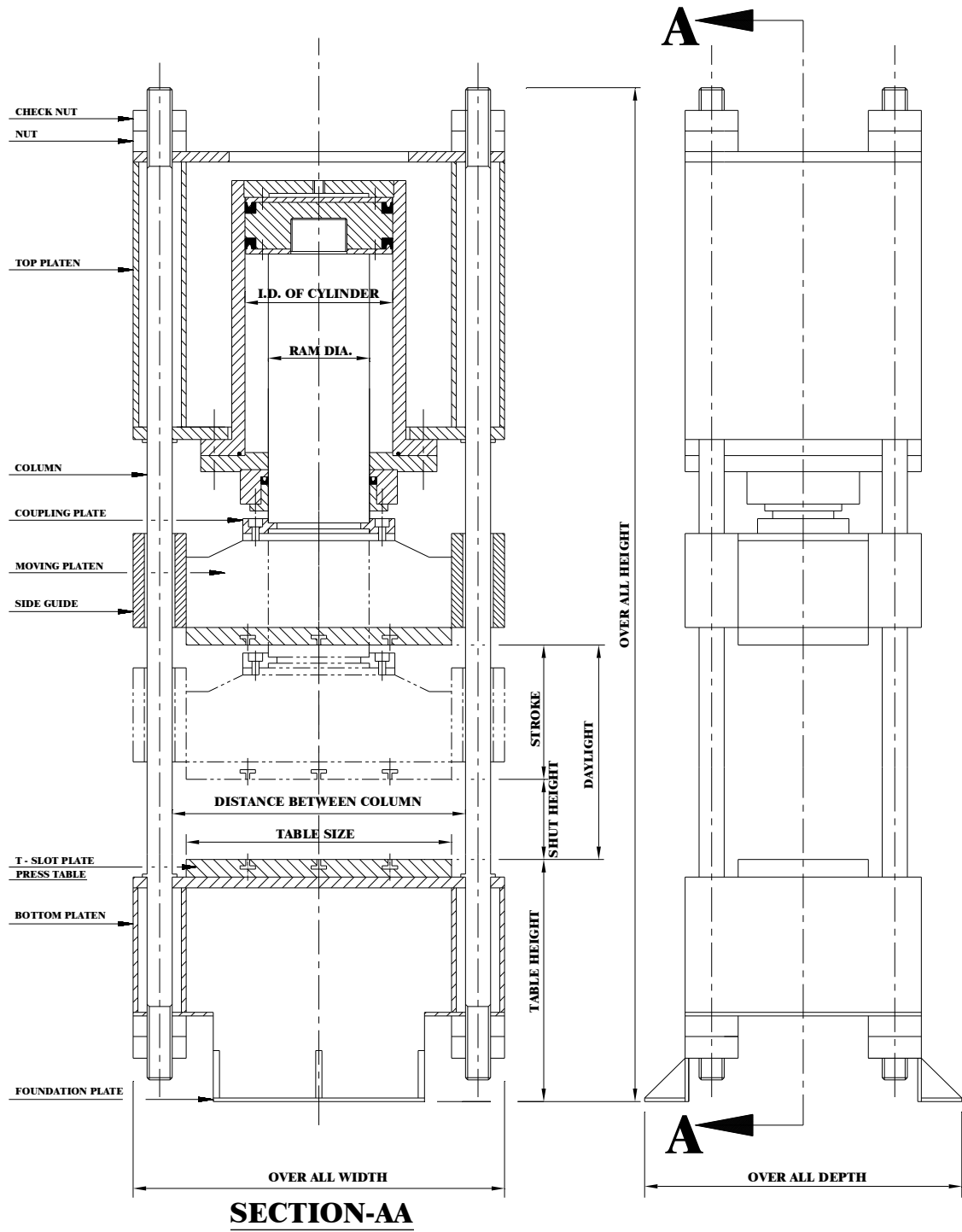

FIGURE NO. 2.1, FOUR COLUMN TYPE HYDRUALIC PRESS

1.2 TERMS RELATED TO PHYSICAL PARAMETERS OF HYDRAULIC PRESS

2.1 I.D. of the Cylinder :-

This is the inside diameter of cylinder. This dimension helps in calculating the pressing capacity (tonnage) of press and approach and pressing speed of Ram (Piston Rod).

2.2 Ram (Piston Rod) Diameter: -

This is out side diameter of Ram. This dimension helps in calculating strength of cylinder. This dimension depends on tonnage of cylinder, stroke of cylinder, type of operation to be performed i.e. pulling or pushing and return speed. For higher tonnage, long stroke and high return speed Ram diameter is more. For pulling operation Ram diameter is comparatively less. For example steel-rope and chain testing machines.

2.3 Day-Light: -

This is the maximum distance between press-table and moving platen, when Ram is at complete retracted position.

2.4 Shut Height: -

This is the minimum distance between press-table and moving platen when Ram is at most extended position.

2.5 Stroke of Cylinder: -

Day light – shut height = stroke. Stroke is maximum distance to which Ram can travel.

2.6 Table Size: -

Table size is clear area on press table, which could be used for pressing operation.

2.7 Distance between column: -

This is the distance between two columns of the press. Left to right and front to back. Distance between columns is kept more than table size as some clearance is

always kept to avoid any damage to column during production operation.

2.8 Throat Distance: -

This specification is only for C-Frame press, This is distance between central axis of cylinder and rear most inside surface of C-Frame.

2.9 Table Height: -

This is distance between ground level and working surface of press-table.

2.10 Overall Size of Press: -

This is the complete length, width and height of press including power pack unit piping and panel. This figure indicates floor area and roof height required for press.

2.11 Weight of Press: -

This is net weight of press including all accessories. This figure is useful for transportation and making foundation.

2.12 Oil Tank Size: -

This is the maximum oil storage capacity of oil tank of power pack unit. It is generally 5-10 times discharge capacity of hydraulic pump used.

Terms related to performance of hydraulic press

2.13 Pressing Capacity: -

This is the maximum force, which could be developed in the hydraulic press, for carrying out desired pressing operation.

In single cylinder hydraulic press, it is force developed by main hydraulic cylinder, while in multi cylinder hydraulic press, it is the sum of force developed by all the cylinders, which are used for direct pressing operation. Those cylinders, which do not involve in desired pressing, but carry out secondary work such as material filling and

ejection etc, are not considered in calculating pressing capacity of press.

2.14 Working Pressure: -

This is the pressure at which pump supply oil to the hydraulic system in normal working operation.

2.15 Maximum Pressure: -

This is the maximum pressure at which system could be operated without overloading the system. Above this pressure hydraulic valves could mal-function and press structure may deform. Hence for safety, hydraulic system are designed for maximum pressure and operated at working pressure, which is less than maximum pressure.

2.16 Speed of Ram: -

Generally Ram has three speeds. Fast approach speed, slow pressing speed & fast return speed. To reduce operation cycle time hydraulic power packs are designed in such a way that it could delivery high flow of oil at low pressure and comparatively low and controlled flow of oil at higher pressure. This enables Ram of hydraulic cylinder to travel at higher speed at no load condition and slow down for carrying out pressing operation.

High approach speed at which Ram travels and come close to material to be pressed is called fast approach speed. Comparatively slow and controlled speed at which Ram presses the material is called pressing speed.

High return speed at which ram retract is called fast return speed.

2.17 Cycle Time: -

This is the time, which press takes to complete one production cycle. It includes material loading time, fast approach time of ram, slow pressing time, processing time, fast return time and time taken to unload the finish component.

Some time hydraulic press has to be kept in compressed condition to some predetermined time for heating, cooling or curing purpose. Time for which material kept compressed condition is called processing time. For example Bakelite is kept compressed in hot condition for thermosetting. In plastic injection molding dies are kept close after injection of molten plastic for cooling purpose. Fiberglass panels are just kept compressed without heating and cooling for curing.

Idle cycle time is sum of fast approach time, slow pressing time and fast return time.(or time which press take to complete one idle cycle without doing any productive operation)

Cycle time gives judgment regarding production of press per hour or per shift. While idle cycle time give idea regarding speed and performance of press as compared to other press.

2.18 Modes of Operation: -

Auto - mode, Semi – auto - mode, and Manual - mode. These terms are used when control panel is used in hydraulic press.

2.18.1 Auto Mode: -

Auto mode [Automatic mode of operation] is that state or condition of machine in which if only once “cycle start push button” is pressed then machine will go automatically through all the sequence of operation, and after completing one cycle it automatically starts the next cycle and keep on repeating it. Press will keep on running and repeating production cycles till it is stopped manually or it get stop signal from timer, counter, material feeding or collecting arrangement or machine protective system against over heating, filter choking etc.

Hydraulic presses for lamination stamping, honing machine etc are operated in this mode.

2.18.1 Semi Auto Mode: -

Semi auto mode (semi automatic mode) is similar to the auto mode but press stopped after completing one production cycle. For next cycle again “cycle start push bottom” has to be pressed.

Plastic injection molding machine, Bakelite moulding press, Rubber moulding presses are operated in this mode.

2.18.2 Manual Mode: -

In this mode, all the operations are carried out by pressing corresponding push - button. As soon as push-button released ram halts. This mode is also called inching mode as Ram could be operated for a inch or fraction of inch of stroke as per the will of operates. This mode is also used for setting of press before switching over to semi auto or auto - mode.

Dishing press, straightening presses and generally operated in manual mode.

3. TERMS RELATED TO FEATURES OF HYDRAULIC PRESSES

In this chapter we will define some of the terms and feature, which a press manufacture refers in his literature or uses in discussion with his customer regarding design, manufacturing and supply of hydraulic press.

3.1 Press with Double Action Cylinder: -

Double action cylinders are those cylinders which can takes power stroke in forward as well as reverse direction. Such cylinder can apply pressing force as well as pulling force. Both forward and reverse stroke achieved by pumping oil under controlled pressure and flow condition, from both the oil port of cylinder. All the general purpose and standard presses uses these types of cylinders. (For further detail refer chapter of Hydraulic Cylinder.)

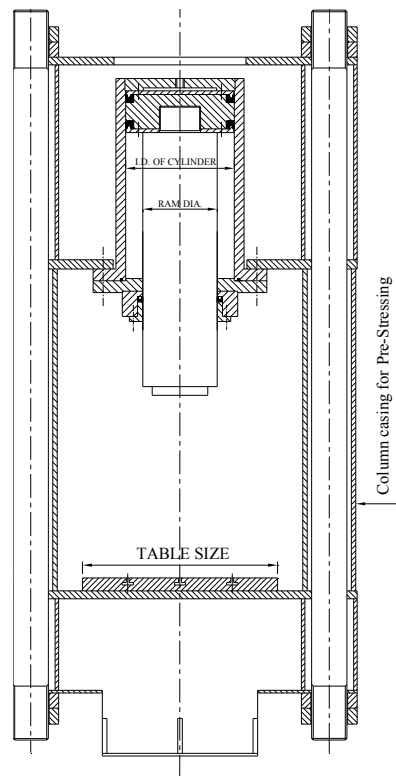

FOUR COLUMN DOWN STROKE
HYDRAULIC PRESS
WITH DOUBLE ACTION CYLINDER

FIG. 3.1

3.2 Press with Single Action Cylinder: -

Single action cylinder can take power stroke only in forward direction. Return stroke may be achieved by additional hydraulic cylinder or by gravity (i. e. own weight of ram and platen)

High capacity cylinder when bore of cylinder is more than 1000 mm, and honing the bore of cylinder become difficult, in such cases cylinder are made single action.

Also in case of up-stroke press, when moving platen weight is sufficiently high and return speed is not very critical than to reduce cost of press, cylinder are made single action and return stroke achieved by gravity (For further de tail refer chapter of Hydraulic Cylinder.)

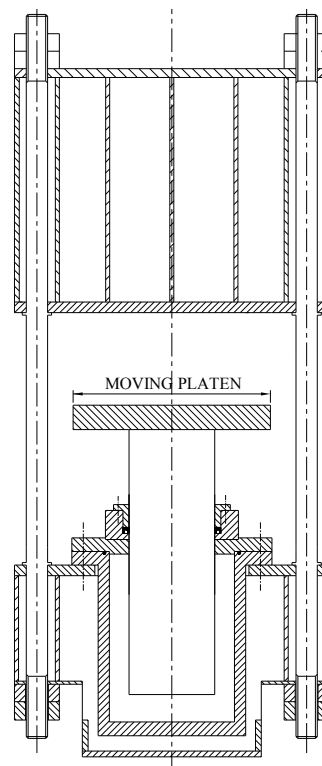

FOUR COLUMN UP STROKE
HYDRAULIC PRESS
WITH SINGLE ACTION CYLIND

FIG. 3.2

3.3 Press with Regenerative Circuit :-

Regenerative circuit is a special hydraulic circuit in which we get high forward speed as compare to common hydraulic circuit using same capacity of pump and electric motor. This is achieved by re-pumping exhaust oil coming out from return port of cylinder back to forward port of cylinder using some hydraulic valves. (For detail kindly refer chapter of Hydraulic Circuits.)

For some operations presses with regenerative circuits are more productive as compare to common presses. Regeneration circuits are commonly used in coining, marking, bakelite molding press etc.

3.4 Press with two Working Speed :-

In a production cycle of press, generally pressing time is less as compare to time taken for approach and return stroke. Hence to save idle time press are designed for two operating speed. Fast approach and return speed and slow pressing speed. Such presses are much productive as compare to single speed press.

3.5 Press with Pressure-compensation Feature :-

Some time press has to hold job under pressure for long time for curing. In such cases motor stops after press develops the desired load. Internal leakage is common in hydraulic system due to wear and tear of internal component of valves, hydraulic seals etc. Due to such leakage pressure drops. But if material to be cured gets less pressure than specified pressure, than it may get spoiled. Hence press is designed in such way that if pressure drops than automatically motor starts, develops the right pressure and stops automatically. Such presses are called press with pressure compensation feature. (Refer chapter of Hydraulic Circuits for further details about pressure compensation circuit)

3.6 Press with De-compression Feature :-

Whenever there is a stress, strain is bound to be there. Body of all press deflects within elastic limit. As pump slowly develops pressure elongation of press column and deflection of press body are smooth and without vibration. And the deflection and elongation is maximum, when press achieves maximum pressing capacity. Solenoids operated direction control

valves are so fast in operation that they take only 0.3 sec to get change over, and that means within 0.3 sec pressurized port of the cylinder gets connected to tank line, and there is sudden fall in pressure.

Such sudden fall of pressure result in sudden fall of stress and strain, and severe jerk and vibration in press body. This phenomenon is highly undesirable and should be avoided.

Hence presses are designed in such a way that the pressure slowly gets reduced from maximum to tank line pressure before taking return stroke of cylinder. Such presses are called press with de-compression feature. To know how decompression - could be achieved (Kindly refer chapter of Hydraulic Circuits.)

3.7 Press with Pre-stressed Column:

All presses deflect under load. Some of the deflection is due to stress developed in press body and some of the deflection is due to clearance between various parts of press.

Such deflections are undesirable in hydraulic press used for precision operation. Deflections due to clearance are much more as compared to deflection due to stress. Such deflections are avoided by pre-stressing the columns of press.

For pre-stressing columns in round column press, additional casing is provided

around column. Refer Fig. No. 3.1. The rods are stretched and bolts tightened, then stretching released. As nuts are tightened in pulling condition of cylinder the stress and strain in press-body was in reverse direction and casing around column was under compression. Hence on releasing pulling load, outer casing will remain under compression load, up to certain extent and columns will remain in tension.

While doing initial stressing of column and column casing, the platen and other parts of press deflect in press-body, and as columns are permanently stress in tension, hence the press part also remain under some stress and will not deflect back corresponding to clearance

Initial columns are loaded to rated press tonnage. In operation, compression get released corresponding to load.

Presses with such feature are called press with pre-stressed column, Aluminum extrusion presses are generally designed in this way.

3.8 Press with Cushion Cylinder, Ejector Cylinder, Blank-holding Cylinder, Auxiliary Cylinder :-

Such presses are not any special types of presses, but these are the presses with addition cylinder, for easy and more accurate and productive operations.

1] Cushion Cylinder:- Some component requires support from bottom side at the time of pressing operation. Such support only offer some resistance, and do not block the movement of main cylinder and component, these bottom support are called cushion, and hydraulic cylinder provided for cushion is called cushion cylinder (e.g. deep drawing operation)

Cushion could be achieved by providing spring, rubber etc. also. But if cylinder is provided then resistance of cushion could be accurately controlled. Hence when cushion is required in pressing

operation, presses with hydraulic cushion cylinder are better and productive.

2] Ejector Cylinder:- Ejectors are required to eject the job jammed in die after pressing operation. A hydraulic cylinder provided to eject the component is called ejector cylinder.

3] Blank holding :- Blank holding is required to hold the job before and at the time of pressing operation. A hydraulic cylinder provider for blank Holding is called blank holding cylinder. Both the features could be achieved by various means. But if hydraulic cylinders are provided them parameter could be accurately controlled. Hence when pressing operation require ejection and blank holding and cost is not a deciding criteria in selecting a press them presses with ejector and blank holding cylinder are more productive.

4] Auxiliary cylinder :- Auxiliary cylinder are those cylinder which are provided in press not to perform the main pressing operation, but to assist main cylinder in carrying out its function smoothly and efficiently. For example auxiliary cylinder are provided along with single action cylinder for retraction. Auxiliary cylinder also provided for miscellaneous operation such as Die sliding, material filling etc.

3.9 Vertical Press: -

In vertical press axis of main pressing cylinder and press is perpendicular to the ground (Refer figure No. --) majority of press are vertical.

3.10 Horizontal Press: -

In this type of press axis of main pressing cylinder and press is parallel to the ground. (Refer Figure No. ---) For example Aluminum / Brass extrusion press.

3.11 Up-Stroke Press: -

This is a type of vertical press in which main pressing cylinder is mounted in bottom

platen and it take up-ward power stroke (Refer Figure No. 3.2)

3.12 Down-Stroke Press: -

This is also a type of vertical press in which main pressing cylinder is mounted in top-plate and it take down - ward power stroke. (Refer Figure No.3.1)

3.13 Single-Day Light Press: -

In this type of press there is a single clear gap between moving platen attached to Ram and press-table mounted on press body.

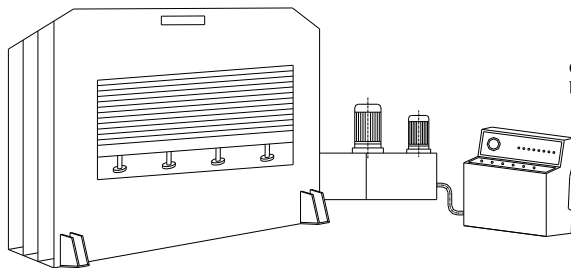

Figure No. 3.3, Multi Day-light Press

3.14 Multi-Day Light Press: -

In this type of press number of addition plates are added between moving platen and press-table to press number of jobs at a time. Plywood, rubber, molding, core - pressing etc are example of multi - daylight hydraulic press.

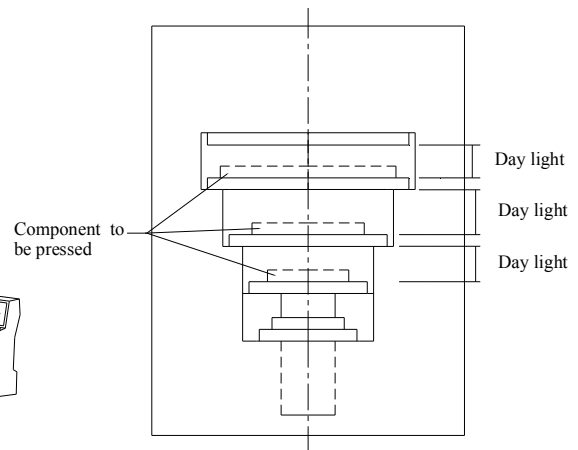

Figure No. 3.4, Three Day-light Press

4. CLASSIFICATION OF HYDRAULIC PRESSES

Basically all presses are same in their basic constitution. They have four main major components.

1 Hydraulic cylinder :- Hydraulic cylinder converts the pressure energy in hydraulic fluid into useful pressing force.

2. Press body :- It withstands the force developed by the hydraulic cylinder.

3. Power pack unit :- This unit supplies pressurized hydraulic fluid in the cylinders under controlled pressure and flow.

4. Control panel :- Control panel governs over-all operation and performance of a press.

Presses are designed and manufactured in different shapes and sizes to suit the specific production, accuracy, strength requirement, and economic constraints. Depending on their shapes, design and they could be divided into six broad categories.

1. Round column press.
2. Fabricated column press.
3. Close- frame press.
4. C-Frame press.
5. Fabricated chamber press.
6. Non-Conventional press.

4.1 Round Column Press: -

Main features of these types of presses are their round columns. In these types of

presses top and bottom platen are fabricated and machined individually and then held together by means of round columns and nuts. As all the components could be machined individually and accurately hence these types of presses are most accurate types of presses, as compared to all other types of presses. (Columns are also referred as pillars).

Round column presses could be further sub-divided into three categories.

1. Two columns press.
2. Three columns press.
3. Four columns press.

4.1.1 Two Column Press: -

In case of two columns press, top and bottom platens are tighten together by means of only two round columns.

Hydraulic presses, which are required to be very accurate and pressing load always remain at the central axis of main cylinder, and also there is no chance of taking any eccentric load, then two column types of presses are used. For example, Lead and solder wire extrusion press. In this type of press material is always fed in fix container and load is applied by plunger attached to the Ram. Hence load always remain at the central axis of main cylinder. Hydraulic universal tensile testing machine is another example of this type of press.

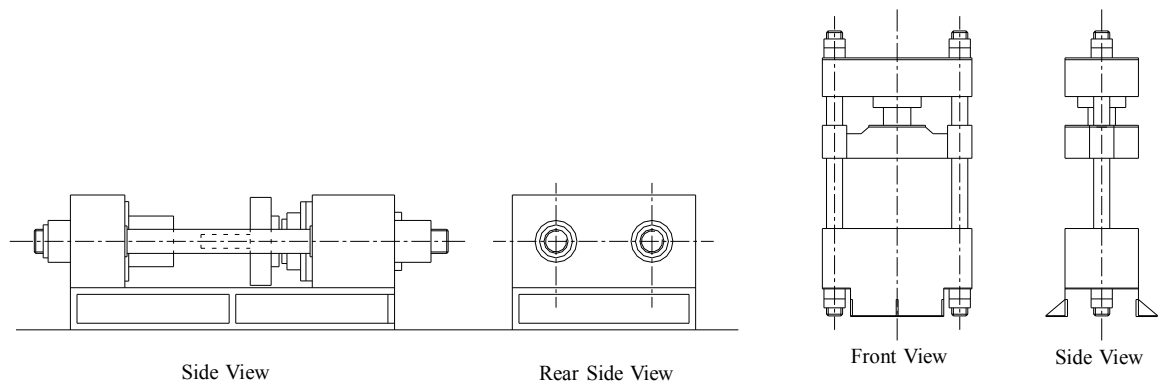

Figure No. 4.1 Horizontal Two Column Extrusion Press

Figure No. 4.2
Vertical Two Column Press

4.1.2 Three Column Press :-

In three column presses top and bottom platen are tighten together by mean of three round columns. Old aluminum and copper extrusion presses of higher capacity were designed in this way. These presses were horizontal, high speed and made for mass production.

Three -column design is stronger than two-column design. Advantage of this type of design in case of extrusion press is that ample space is available for shearing the rejected billet and loading red hot billets in container by means of over head crane.

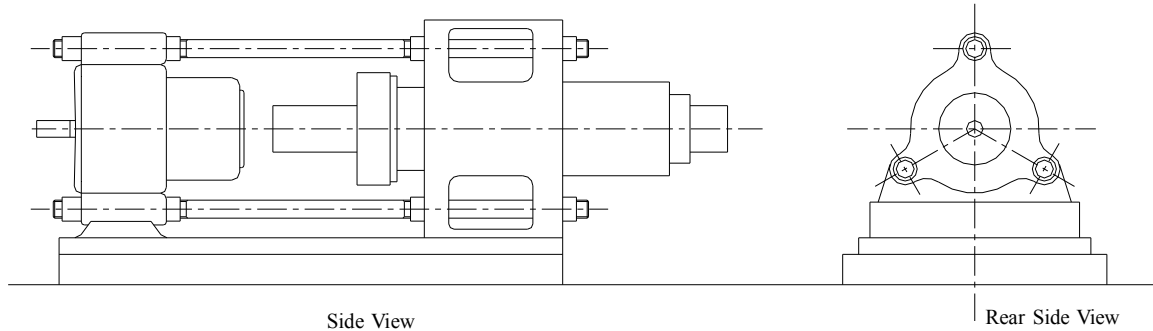

Figure No. 4.3 Horizontal Aluminium Copper and Extrusion Press

4.1.3 Four Column Press:-

In four columns presses top and bottom platen are tighten together by means of four round column. These types of presses are widely used in industry as compared to other type where occurecy is more critical between Dies. For example, power compacting presses, plastic injection moulding machine etc.

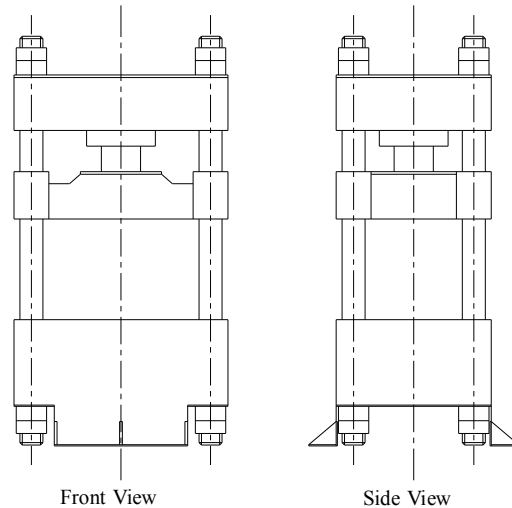

Figure No. 4.4 Four Column Hydraulic Press

4.2 Fabricated column press :-

In this type of presses top and bottom platens are permanently welded together with the help of fabricated columns. Fabricated column presses are more sturdier, economical and has less deflection under load as compare to round column presses.

Fabricated column press also could be divided into two categories.

- (1) Fabricated Four-column press.
- (2) Fabricated Two-column press or H-Frame press.

4.2.1 Fabricated Four Column Press: -

High capacity hydraulic presses with large size table are manufactured on the design of fabricated four-column press. As it is sturdier and gives ample space to work and inspect pressing operation from all sides, as compare to, two-column press.

For example, deep drawing press for automobile body, punching and blanking of large size of M.S.Steel etc.

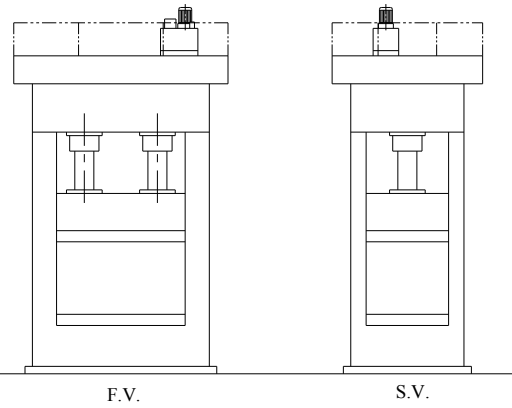

Figure No. 4.5, Four Column Press

4.2.2 Fabricated Two Column Press or H-Frame Press: -

Medium and low capacity and economical presses are manufactured on the design of fabricated two - column or H-Frame press.

In low capacity presses rolled M.S. channel or I-section are used as side column and in case of medium capacity press it is fabricated from steel plate.

Rubber molding, variable-day-light presses used in garages are example of H-Frame press.

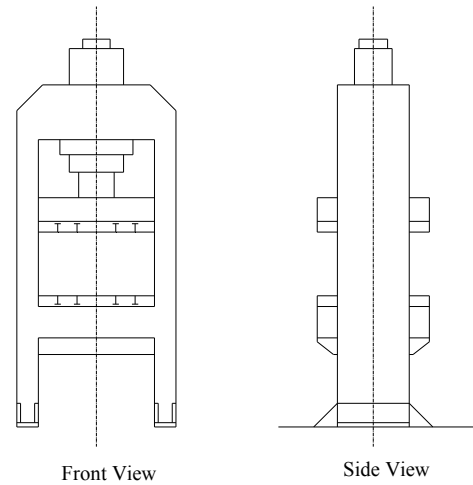

Figure No. 4.6, H-Frame Press

4.3 C-Frame Press: -

In these types of presses, press-body is of C-Shaped. When free space required from three sides of press table to work for loading and unloading of pressed component then this type of presses are designed.

These types of presses are most fragile, susceptible to deflection and cracking from inside corners, if not designed and used correctly as compare to other type of press. As main cylinder placed eccentric to central axis of press-body, it applies eccentric load on press-body hence heavier press-body is required as compare to same capacity of other type of press.

These types of presses are also called as single press. Some example of C-Frame presses are as follow.

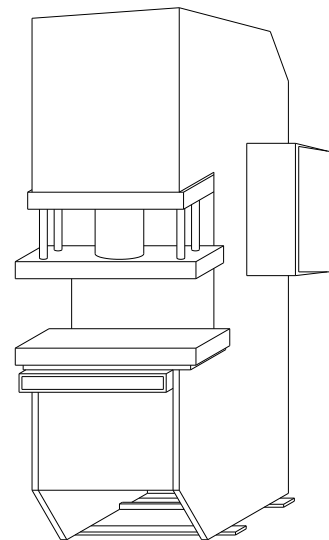

Figure No. 4.7, C-Frame Press

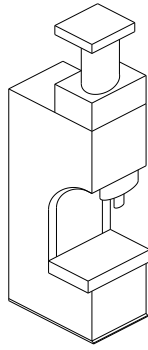

Figure No. 4.8, Hydro pneumatic 'C' Press.

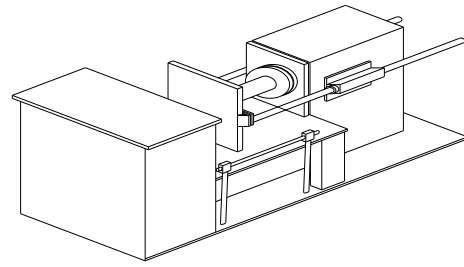

Figure No. 4.9, 150 Ton 'C' Press for Bending and Straightening of Rolled Section

4.4 Close-Frame Press: -

In case of close-frame press, over all structure of press is in a shape to square ring. A schematic diagram of close-frame press is shown in figure No. 3.10. In case of small size of presses, they are made by cutting window in steel plates and assembling together two or more such plates to make a press-body. In this type minimum welding is required as top, bottom and side columns are all internal

In case of large presses required for general fabrication, such as dishing, plate- bending, straightening and pre-punching of plates for rollings top, bottom platens and side columns are fabricated separately then welded together .

Difference between fabricated column press and close-frame presses are as follow.

- 1) Generally accuracy is critical in case of fabricated column press, and generally accuracy is not very critical in case of large size of close frame press
- 2) Side columns of fabricated column presses are long compared to top & bottom platen, and some times column extend down the bottom frame and form the standing-leg or foot of press while Close -Frame presses rest on their bottom platen only.
- 3) Large size of Fabricated column presses are made in premises of press manufacturer then supplied.

These presses are accurate and requires machining of fabricated platens and columns and then assembled together. Parallelism and flatness of platens is controlled as per standards of machine design. While in case of large size of close-frame press as a accuracy may not be very critical, hence manufactures of press may manufacture press body him self or he can give fabrication drawing of press body to customer and customer himself can fabricates it, if he has the facility and knowledge. As many time press body does not require machining, hence parallelism and flatness are not as per standards.

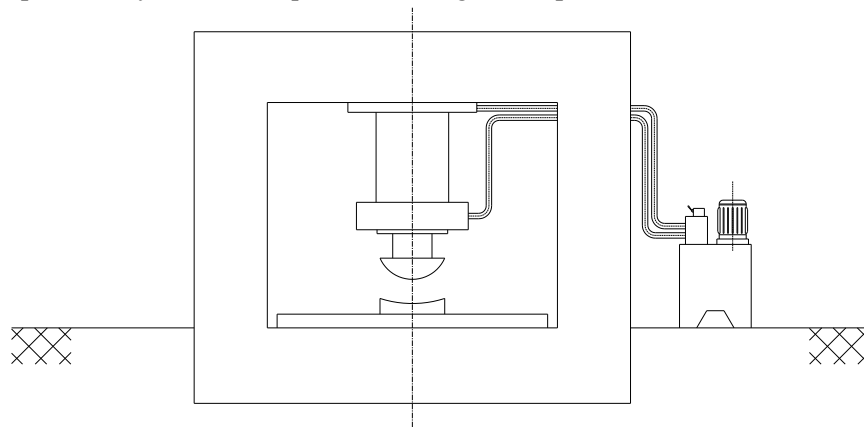

Figure No. 4.10, Close Frame Press for Making Dish ends

4.5 Fabricated Chamber Press :-

In this type of hydraulic press a steel fabricated box-structure or container form the main body of hydraulic press. Main cylinder, various doors, feeding arrangement auxiliary cylinder are mounted on these fabricated box-structure as per the requirement of production and operation. Fabricated chamber act as load bearing member of press. Some time they also act on container for material to be compressed. Bailing presses and extrusion press are some of the example of these types of presses.

A schematic diagram of fabricated chamber press is as follow.

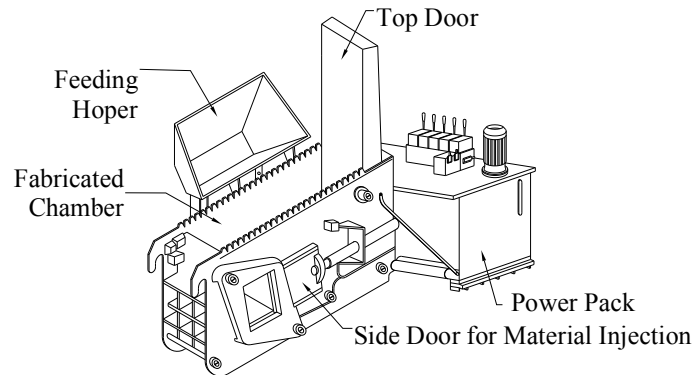

Figure No. 4.12, Scrap Bailing Press

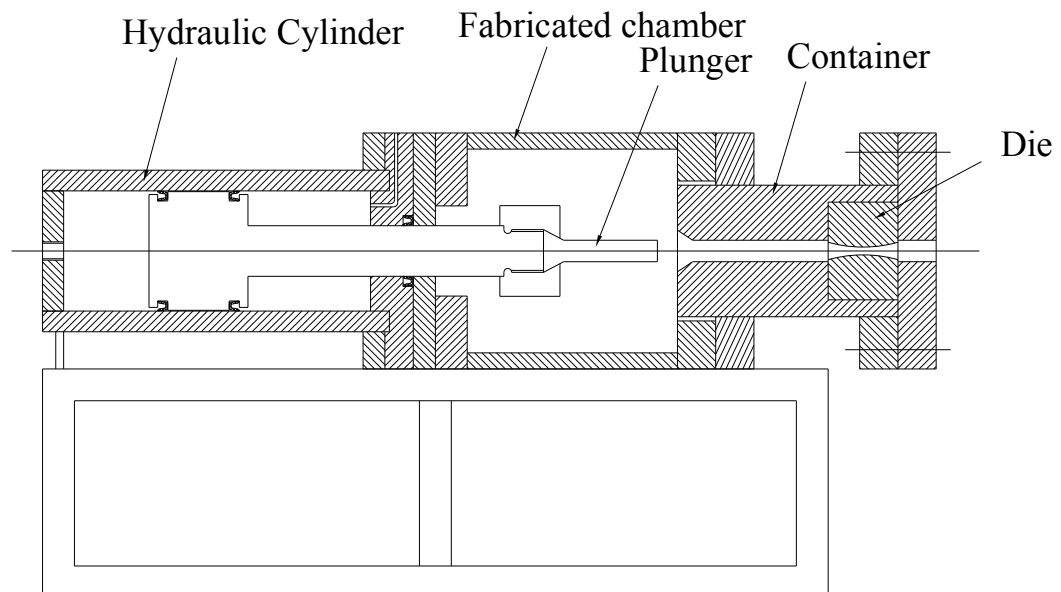

Figure No. 11 Extrusion Press

5.1 DESIGN OF PRESS-BODY

Most difficult and risky part of design, in a press is design of “Press-body”. This is because we can not easily and clearly define the type and magnitude of force acting on any structural member of press-body. To simplify the theoretical design work we take following steps.

1. We simplify the pattern of force acting in a press-structure, and ignore the complex action and reaction forces acting on various structural member.

2. We take high factor of safety, and over design various structural member, considering full load of cylinder will act on them. While in actual various other member will share the load.

3. We try to calculate the dimension of a standard section namely; I-section, Box-section and Vertical-plate, to withstand the force develop by cylinder. But modify them drastically to suit the over all design and dimension of press-body.

Hence whatever we are going to study and calculate is simplified and approximate design. If you want to do exact calculation then kindly read the “**Plate and shell design**” written by Timo and Shinko. But what ever simple calculation we do, on same calculation and design author of this book has manufactured more than hundreds of press of all types which are working most satisfactory in industry.

Before proceeding to the actual design calculation, we revise some of the basic engineering knowledge, which are essential for design purpose.

5.1 Bending Stress: -

When a static or dynamic load acts on any part of hydraulic press, then along with simple, tensile, compressive, shear stress, it also develops bending stress.

Consider a beam subjected to a bending moment M as shown in figure.

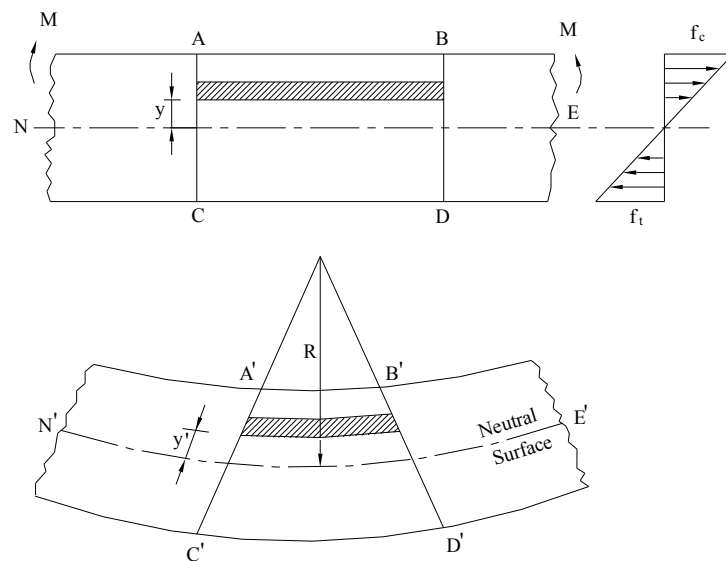

Figure No. 24.1

Due to bending moment fiber AB will be under compression, fiber CD is under tension. At NE fibers are neither under tension or compression. This surface is called neutral surface. The intersection of the neutral surface with any normal cross-section of the beam is known as neutral axis.

The bending equation is given by

$$\frac{M}{I} = \frac{f_b}{Y} = \frac{E}{R}$$

Where

M = Bending moment at the given section

f_b = Bending stress

I = Moment of inertia of the cross-section about the neutral axis.

Y = Distance from the neutral surface to the extreme fiber.

E = Young's modulus of the material of the beam

R = Radius of curvature of the beam.

Z = Section modulus

From above equation bending stress is given by

$$f_b = \frac{M}{I} \times y = \frac{M}{I/y} = M/Z$$

For bending moment formula, we made following assumption: -

1. The material of the beam is perfectly homogeneous. And isotropic (That is, it is same material throughout and of equal elastic properties in all the direction)
2. The material of beam obeys Hook's law.
3. The Young's modulus E is same in tension and compression.

Note: - In case of symmetrical section, the neutral axis passes through its geometrical center. While in case of unsymmetrical center, centroid is to be calculated and then extreme fiber distance is obtained.

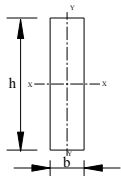
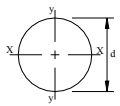
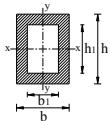
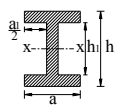
Sr. No.	Section	Area (A)	Moment of Inertia (I)	Section Modulus $Z=I/y$
1		bh	$I_{xx} = bh^3/12$ $I_{yy} = bh^3/12$	$Z_{xx} = bh^2/6$ $Z_{yy} = bh^2/6$
2		$\pi/4 d^2$	$I_{xx} = I_{yy} = \pi d^4/64$	$Z_{xx} = \pi d^3/32$
3		$hb - h_1b_1$	$I_{xx} = (bh^3/12) - (b_1h_1^3/12)$ $I_{yy} = (bh^3/12) - (b_1h_1^3/12)$	$Z_{xx} = (bh^3 - b_1h_1^3) / 6h$ $Z_{yy} = (bh^3 - b_1h_1^3) / 6b$
4		$hb - h_1b_1$	$I_{xx} = (ah^3/12 - a_1h_1^3) / 12$	$Z_{xx} = (ah^3 - a_1h_1^3) / 6h$

5.2 Fatigue and Endurance limit :-

When a material subjected to repeated stress. It fails at stresses much below the yield point stresses. Such type of failure of a material is known as fatigue. The failure is usually caused by means of a progressive crack formation which are usually fine and microscopic size, and which get developed due to tool mark while machining.

A standard polished specimen is subjected to cyclic bending in a fatigue testing machine. bending load on specimen varied and number of cycle counted after which the specimen failed. When a stress and number of cycle graph plotted. It is found that material will not fail whatever may be the number of cycle, bellow a certain stress level. This stress is known as endurance or fatigue limit (f_e). For steel fatigue limit is **half of its ultimate tensite stress**. Fatigue limit increase with increase in surface finish of material.

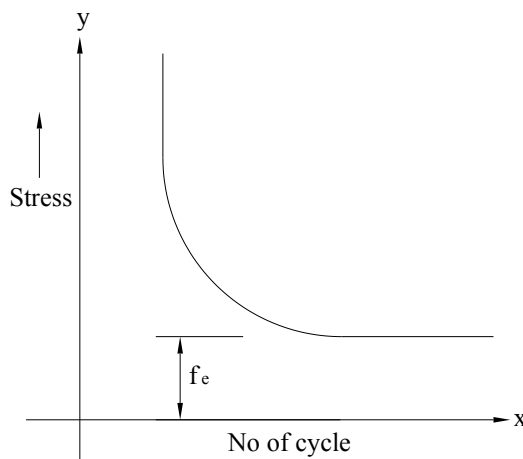

Figure No.24.2

5.3 Selection of Type of Construction of Hydraulic Press- Body.

Hydraulic Press-body is designed and made on four standard type of cross-section and construction; newly

1. Vertical Plate type of Construction.
2. Box-Section type of Construction.
3. I-Section type of Construction
4. Single horizontal plate type of Construction.

Depending on various parameters we select anyone type of above-mentioned standard Cross-section,. Then we calculate size of a standard selected cross section; the calculated size of cross sections may or may not shites to the required dimension of press. Hence after calculating the size we modify them without decreasing strength to suit the press dimension.

Some of the parameter on basic to which various type of construction is selected is as follow.

5.4 Vertical-plate type of construction: -

When size of platen is almost equal to the outside diameter of cylinder, and cylinder is to be inserted in press body (platen) to reduce the dimension of press them vertical plate type design for press-body is selected.

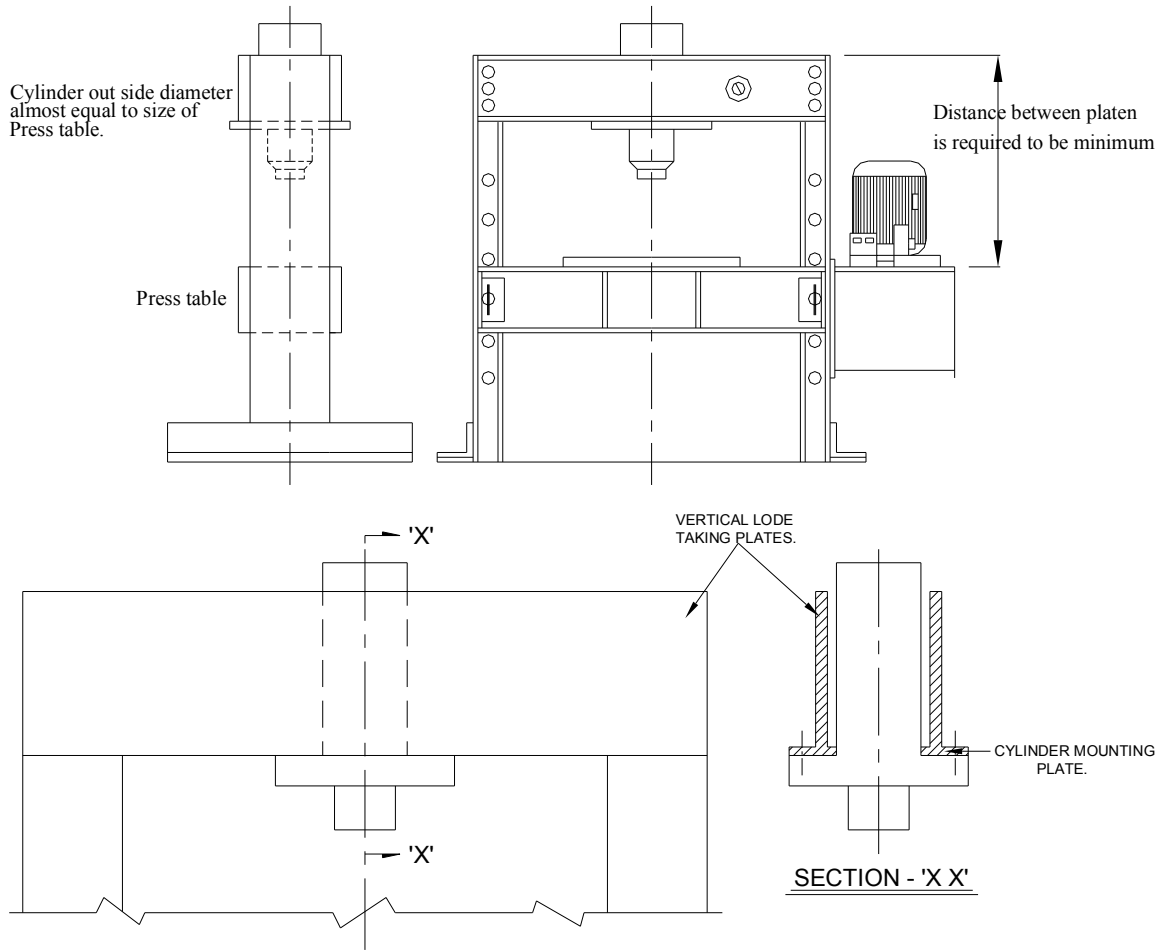

VERTICAL PLATE TYPE OF CONSTRUCTION

Figure No.24.3

5.5 Box-section type of construction: -

When platens of hydraulic press-body can be completely enclosed, and there is no opening in platen for cylinder mounting, ejector or for any other purpose, then box construction for complete press-body or any of its platen or column is selected.

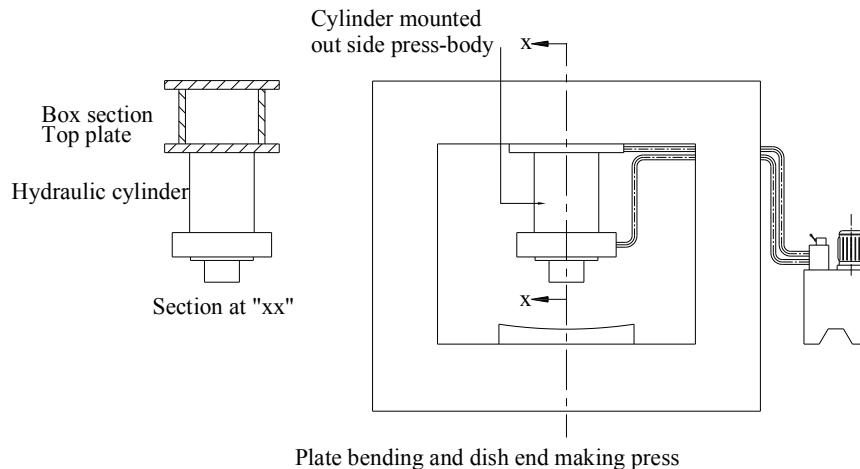
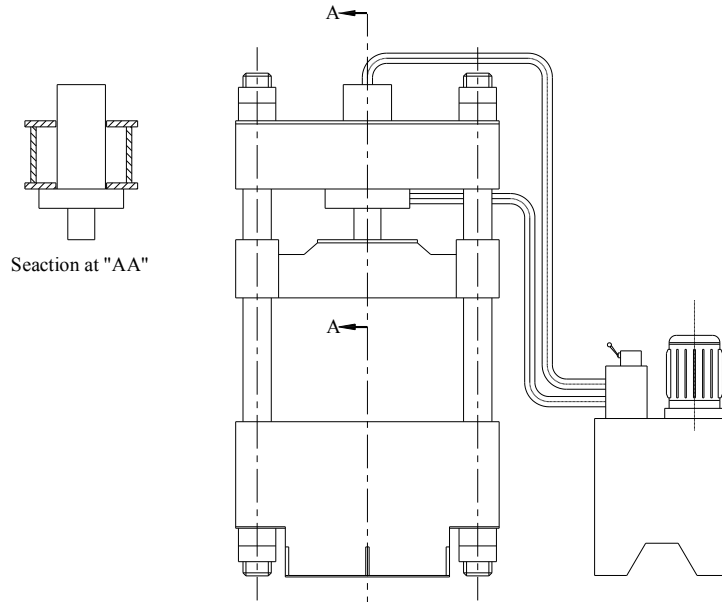

Figure No.24.4

5.6 I-section type of press-body construction :-

When the size of press-body or any of its platen is large enough, as compare to cylinder dimension, and there are windows and opening in press-platens, for cylinder mounting, guide rods etc,

Then for such complete press-body or any of its platen, or column I-section type of construction is selected.



Four column press used for sheet metal pressing

Figure No. 24.5

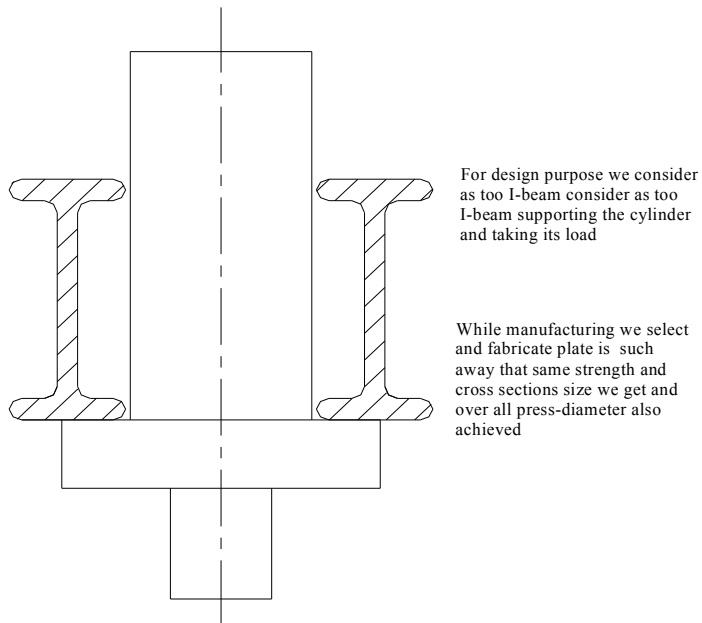

Figure N0.24.6

5.7 Single-solid plate type of construction; -

When capacity of press is less, its size is also small and a simple press is to be made then single solid plate type of construction is selected.

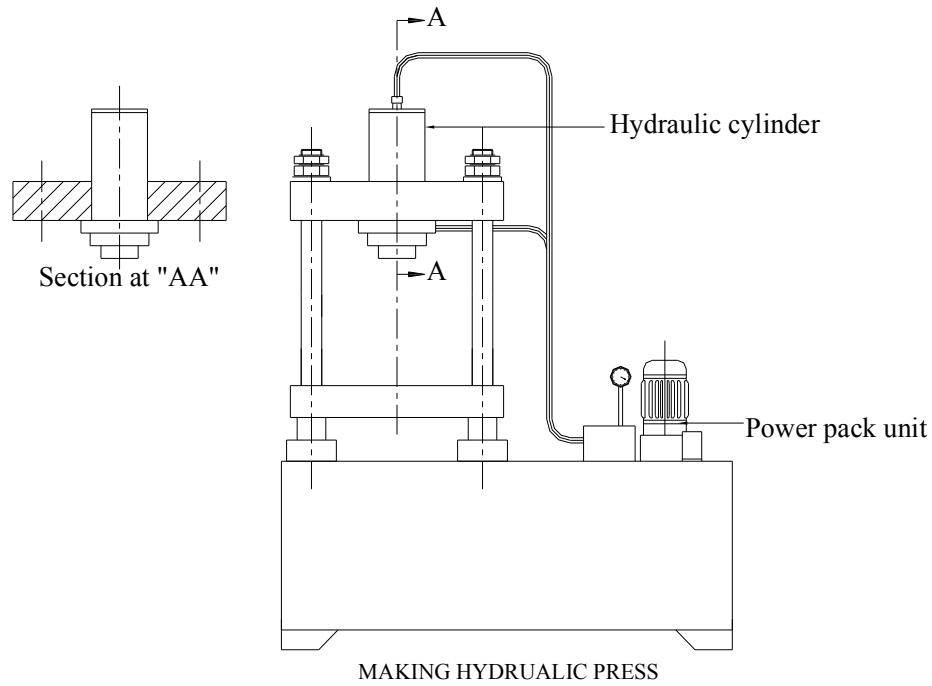

Figure No.24.7

5.8 Design of press-body with vertical plate type of construction

This type of construction is selected when width of cylinder side plate is almost equal to outside diameter of cylinder, and cylinder is to be accommodated in platen. Or there is large opening in platen and making side vertical plate into an I-section is not possible.

Example of this type press is, adjustable platen type general-purpose press used in garages, as shown in following figure.

A general design of vertical plate type of construction is as follow

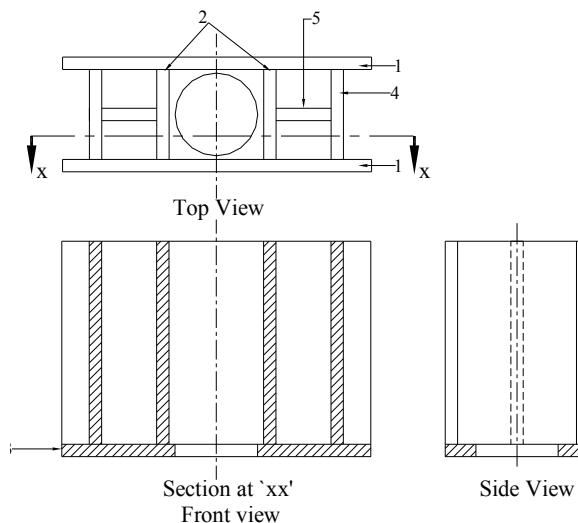

Figure No. 24.8

In above drawing, the name and purpose of platen are as follow.

Plate No.	Name of Plate	Purpose of Plate
1.	Main vertical plate	It withstand the force developed by hydraulic cylinder.
2.	Cylinder supporting plate	It support the cylinder it transferor load developed by cylinder to plate no.1. It avoid backing- in of plate no.1
3.	Cylinder mounting plate	This is used to hold the cylinder with platen.
4.	Column supporting plate	These plates transfer load from plate no.1 to columns
5.	Reinforcement ribs.	These plates are used to strengthen the press body. They avoid Buckling of plates and given strength against twisting

5.9 Design Procedure: -

Design of main vertical plates

1. We assume that top platen is made from single vertical plate.
2. We assume that the cylinder apply force on single vertical plate at single point.
3. We assume that press has only two columns, both attached at both end of single vertical plate and column also offers reactions at single point.

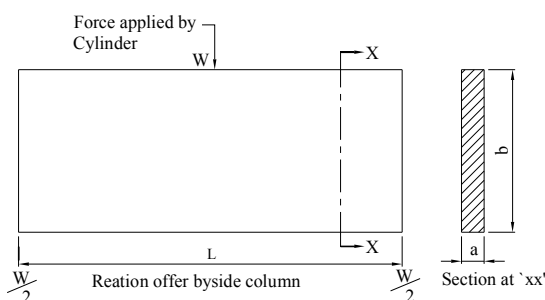

Figure No. 24.9

1. Single vertical plate is similar to simply supported beam with bending stress, Hence we are bending equation as follow

$$(M \div I) = (fb \div y) = (E \div R)$$

M= Bending moment at given section

Fb= Bending stress

I= Moment of inertia of the cross section about the neutral axis

Y= Distance from the neutral surface to the extreme fiber

E= Young modular of the material of the beam

R= Radius of curvature of the beam

From above equation bending stress is given by.

$$Fb = y \times (M \div I) = M \div (I \div y) = M \div Z.$$

$$I \div y = \text{Section modular} = Z$$

$$M = wl \div 4$$

$$I = ab^3 \div 12$$

$$Y = b \div 2$$

Hence

$$Fb = M \div 2 = WL \div 4 \div (ab^3 \div 12) \div (b \div 2)$$

$$Fb = (WL \div 4) \div (ab^2 \div 6)$$

In above equation fb is known as it depends on material of construction of vertical

plate. W and L are also known, as W is cylinder capacity and L distance between columns of press. Hence only a' and b are unknown.

' a ' and ' b ' that is thickness and height of vertical plate is divided by trial and error method.

2. Criteria to decided ' a ' and ' b ' while dividing value of plate thickness (a) and height of plate (b), following figure and fact must be remembered.

a. Press-body or press-platen one all welded structures. Each plate in platen is welded to many other plates. Welding produce distortion. Single vertical plates also get distorted to some extent. Hence thickness of plate must be sufficiently high to minimize the distortion.

b. Moment inertia of plate is above equation is ($ab^3 \div 12$). For a safe and constant bending stress (fb), a slight increase in height (b) result in high reduction of plate thickness (a).

Hence a higher value of (b) is always desirable. But large height of vertical plate, result is difficulty in fabrication of press-structure

Hence value of (a) and (b) always should be divided considering convenience in fabrication.

c. Generally length of press-platen ($L + \text{Column thickness}$) and height (b) are in ratio of 2:1 to 3:1.

d. Press is operated by workman. For higher production it should be convenient in operation. The table height should be easy to loading-unloading component to be processed. Hence height (b) should be selected according.

e. Press should look good esthetically. Hence it is over all dimensions should be proportionate. Hence height (b) should be selected as per width and height of press.

Step-II:-

a) Once thickness (a) and height (b) of main vertical plate is calculated to withstand fall face developed by cylinder, we proceed further for design of press-body as follow.

b) We split single vertical plate in to two plates with half the wall thickness ($a \div 2$), as we require minimum two plates to completes a press platen in category of vertical plate design

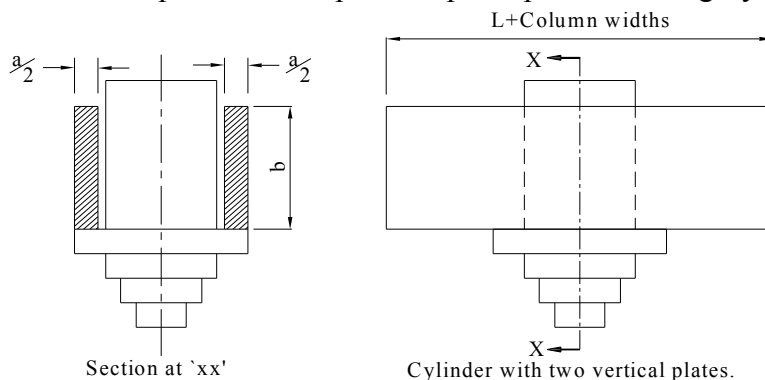

Figure No. 24.10

c). Two vertical plates has to be connected to each other firmly and cylinder also should be supported from all our sides. Hence we provide two additional plates adjust to cylinder, and interconnecting plates no.1, as shown in following diagram. We name these plates as plate no. (2).

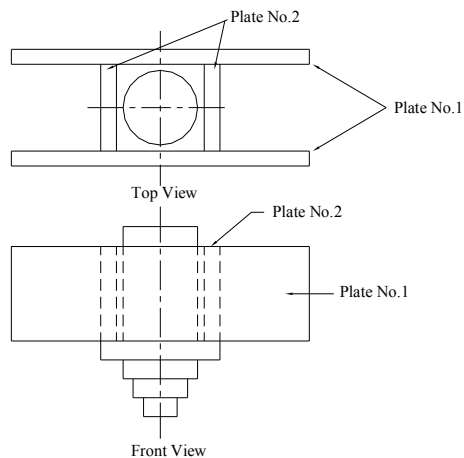

Figure No. 24.11

b. If press consist of only vertical plates and columns, and loads one perfectly concentric to center of axis of cylinder and press- body, then also press will work , and its structure not going to fail.

But in actual practice load is never concentric to axis of press, and load on platen is also of twisting type along with bending a compressive load. Which result in twist of vertical plates, and platen.

When load is eccentric, and it is causing twisting load on press-platen, then we can not exactly say that only half the cylinder load is coming on each of the two vertical plates .We also can't predict that which plate is taking less load.

Because all these uncertainties, we over design the press platen, make such assumptions, which seems to be absurd. But then also for safe design we do it.

c. For design of platen no. 2, we assume that cylinder is only supported by plates no.2, and plate no.2 is transferring load from cylinder to plates no1 as shown as following sketches

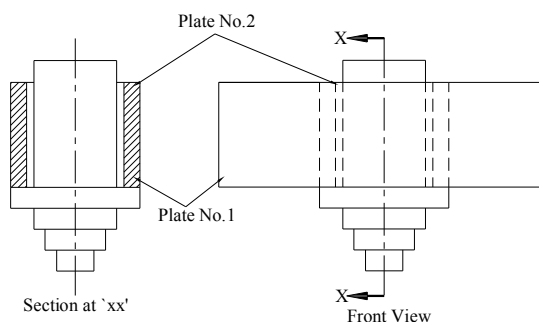
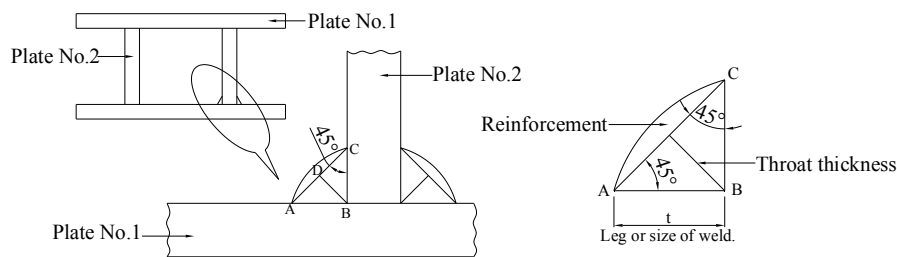

Figure No. 24.12

d. Plate no.2 is welded to plate no.1. To transferor cylinder load to plate no. 1,we calculate the welding required for safe transfer of load. Then depending on size of welding, we divide the size of plate no.2.



Shear strength of joint for single parallel fillet

$$P = \frac{t \times l}{\sqrt{2}} \times f_s$$

Figure No. 24.13

e. The joint between plate no.1 and plate no. 2 is subjected to shear stress. Hence shear strength of the joint for said double parallel fillet type of welding joint could be calculated as

$$2 (t \div \sqrt{2} \times fb)$$

t= Size of weld

l= Length of welding joint. Generally we keep it same as (b) that is height of plate no.1

fb= Permissible shear stress of welded-metal.

We assume that each joint withstand half the force developed by cylinder.

$$W \div 2 = 2(t \div \sqrt{2} \times fb)$$

In above equation all the parameters are known except (t). Hence it can be calculated. The thickness of plate No.2 will be twice the value of (t), and height same as plate No. 1, that is (b).

f. Some time we get value of (t) too small. In that case we use thumb rule. We should keep the thickness of plate no.2 between 50 to 100% of thickness of plate no. 1, and height between 75 to 100% of plate no.1

Hence first we reduce height to reduce weld length (l) and increase weld size (t). And if even after reducing length up to 75% the final thickness plate no.2 we get less than 50% of plate no.1 then we select its thickness as 50% and height 75% of plate no.1.

5.10 Design of cylinder mounting plate (plate No.3):-

a. Cylinder is fitted in press body. The place where cylinder is fitted should be machined properly so that central axis of cylinder should be as per requirement of press body.

b. When cylinder applies load on component to be pressed it equally pushes-back the platen on which it is mounted. If the plate on which it is mounted is perfectly matching to cylinder, this cylinder will apply a uniformly distributed load. And its surface is not matching properly then it will apply a concentrated load.

Bending stress in case of concentrated load is much higher than uniformly distributed load. Hence cylinder-mounting plate should be perfectly machined

c. Cylinder has its own weight. A 1000 Ton capacity cylinder with 1000mm stroke way weight about 5 Ton. Some time cylinder should pull the component instead of pushing in such case the bolts fixing cylinder to the cylinder mounting plate should be of sufficient size. Plate should also be sufficiently thick to have required number of threads.

d. The size of cylinder mounting plate is decided on above three criteria. First thickness of plate is divided on the basic size and number of bolt it has to accommodate. There some thickness is added as machining allowance. Width of cylinder mounting plate is equal to or more than size of cylinder mounting flange. Depth or length of plate is as per depth of press-plates.

e. In case of vertical plate design as cylinder is almost pressing against vertical plate, hence cylinder mounting plate do not take any bending load, and used mainly to hold cylinder in position. While remaining three design this plate also take bending load, and very critical in press-body.

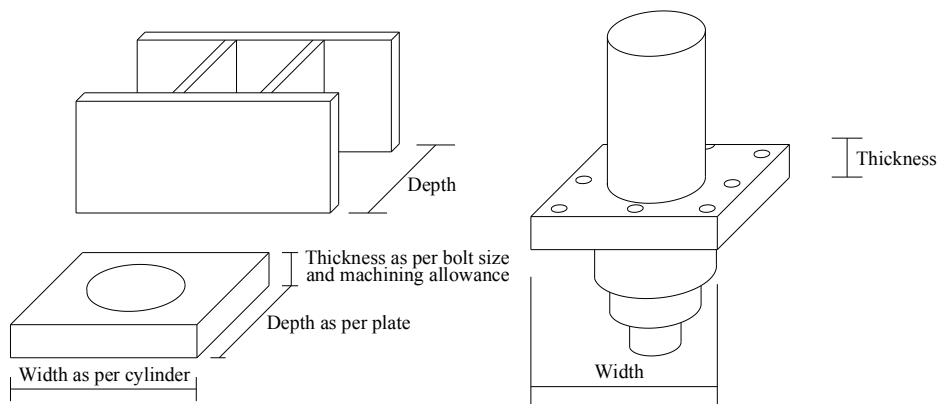

Figure No.24.14

5.11 Design of column supporting plates (Plate No. 4)

a. In case when column press between two main vertical plates and welded directly to it , then these plates are not required.

b. When plates is fully cover from one side by cylinder mounting plate, then this plate is provided to transferor the load from press platen to press column.

c. Thickness and height of this plate is same as plate No.2.

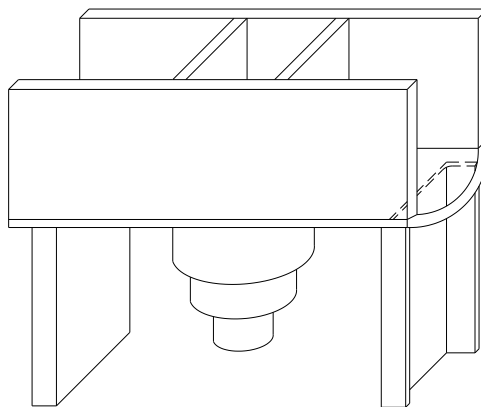

Figure No.24.15

Figure No.—— is an exaggerated sketch to show the importance of plate no. 4 . It load is transferred only through cylinder mounting plate (No.3). Then plate (No.3) may dished out under load as shown in sketch.

Plate No.4 provided strength to plate No.3 and transferor load from column to plate No. 1 through out its height.

5.12 Design of Reinforcement Ribs (plate No.5)

a. In case of long press –body, in which distance between both column are too much, then additional stiffeners one required between plate No.2 and plate No.4

b. In absence of stiffener the plate No.1 try to buckle in following way.

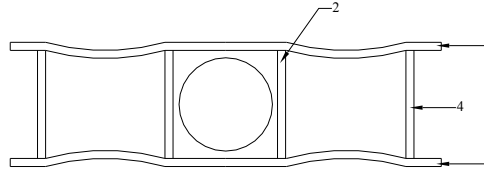

Figure No. 24.16

Hence to reinforce the strength of platen ribs or thin plate one provided.

a. Ribs could be provided in following two ways.

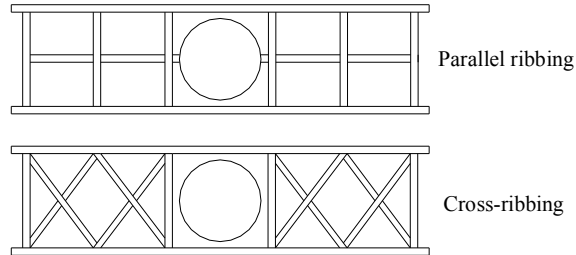

Figure No. 24.17

Cross-ribbing give more strength as ribs also take the bending load. While in case of parallel ribbing, rib parallel to plate No.1 and 4 could not take any bending load.

a. Height of ribbing plate one kept same as plate No.1, and thickness between 20 to 40% of thickness of plate No.1 or between 6mm to 20mm.

b. Cross-ribs and ribs parallel to plate No.1 also under go the bending load and share some of the load of plate No. 1. Hence their thickness and reduction in thickness of plate No.1 can be calculated. But those complicated calculations are beyond the scope of this book. Hence we do not discuss it.

5.12 Design of I- section type of construction.

When Size of press-plant is large enough, as compare to holes or opening provided for hydraulic cylinder or ejector etc. And when it is not possible to make a box-section, then best alternative is to design press body on basis of design of I-section.

Majority of presses designed on basis of I-section design. And particularly cylinder side platen when cylinder is filled in press-body is mostly I-section design.

An example of I-section construction for press-frame is as follow.

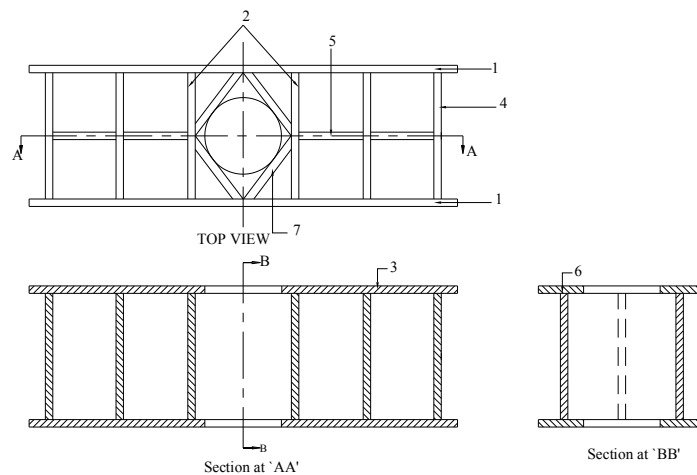

Figure No.24.18

In above drawing, the name and purpose of plate are as follow.

Plate No.	Name of Plate.	Purpose of Plates.
1.		As described in table.
2.		-do-
3.		-do-
4.		-do-
5.		-do-
6.	Platen-cover-plate	This plate is mounted other side of cylinder mounting plate or press-table. Size of this plate is square as cylinder-mounting plate or press- table. And purpose is to give plate No. 1 and 3, an I-section shape.
7.	Cylinder supporting ribs.	There rib gives addition support to cylinder. Avoid dishing of cylinder mounting plate, and avoid collapsing of vertical head bearing plate no.1