

RE 17 334/02.03

Replaces: 07.02

**Hydraulic cylinder
Types CDH2 / CGH2**

Series 1X

Nominal pressure 250 bar (25 MPa)

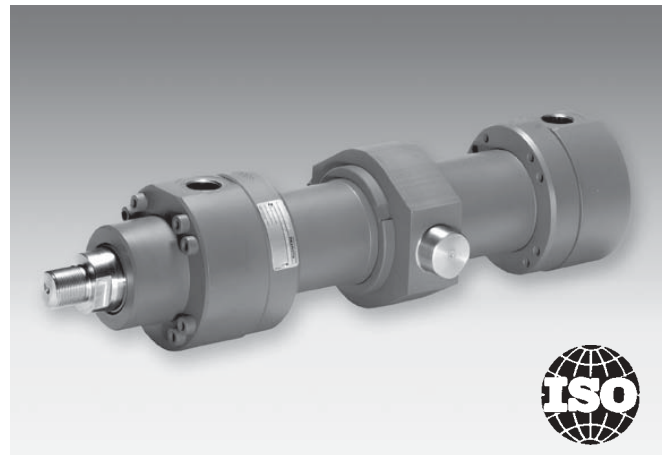

H/A 4652/95

Type CDH2MT4/...

Overview of contents

Contents	Page
Technical data	2
Areas, forces, flows	2
Ordering details	3
Cylinder weight	4
Tolerances	4
Mounting style overview	5
Plain clevis at base MP3	6
Self-aligning clevis at base MP5	8
Round flange at head MF3	10
Round flange at base MF4	12
Trunnions MT4	14
Foot mounting MS2	16
Flange connections	18
Position measuring system	20
Proximity switch	24
Coupling	26
Self-aligning clevis	27
Fork clevis	28
Mounting block	29
Buckling	31
End position cushioning	34
Spare parts	37
Tightening torques	39
Seal kits	40

Features

- Standards: DIN 24 333, ISO 6022
CETOP RP 73 H, VW 39 D 921
- 6 mounting styles
- Piston Ø: 40 to 320 mm
- Piston rod Ø: 25 to 220 mm
- Stroke lengths up to 6 m
- Self adjusting end position cushioning



© 2003

by Bosch Rexroth AG, Industrial Hydraulics, D-97813 Lohr am Main

All rights reserved. No part of this document may be reproduced or stored, processed, duplicated or circulated using electronic systems, in any form or by means, without the prior written authorisation of Bosch Rexroth AG. In the event of contravention of the above provisions, the contravening party is obliged to pay compensation.

Technical data

Standards:

The installation dimensions of the cylinders and mounting styles meet the requirements of DIN 24 333, ISO 6022 and CETOP RP 73 H.

Nominal pressure: 250 bar
Static proof pressure: 375 bar
 Higher operating pressure on request.

The specified operating pressure are only valid for applications with shock-free operation. If extreme loads occur, e.g. as happens in high sequence cycles, the fixings and piston rod thread connections need to be designed for durability (fatigue strength).

Installation: Optional

Pressure fluid:

Mineral oils DIN 51 524 (HL, HLP)

Phosphate ester (HFD-R; for seal version "C"
 -20 °C to +50 °C)

HFA (+5 °C to +55 °C)

Water glykol HFC on request

Pressure fluid temperature range: -20 °C to +80 °C

Viscosity range: 2.8 to 380 mm²/s

ISO cleanliness class:

Maximum permissible degree of contamination of the pressure fluid is to ISO 4406 (C) class 20/18/15.

Stroke velocity: 0.5 m/s (depending on the connection ports)

Bleed screw as standard: Secured against unscrewing

Acceptance: Each cylinder is tested to Bosch Rexroth standards.

Cylinders whose application data lies outside the stated values can be offered as a special version.

Cylinders with piston $\varnothing > 320$ mm are available on request as an ABS (**A**pplication **B**ased **S**tandardisation) cylinder.

For assembly, commissioning and maintenance of hydraulic cylinders, please take the details stated within the catalogue sheet RE 07 100 into account!

Areas, forces, flows

Piston Ø mm	Piston rod Ø mm	Area ratio φ A_1/A_3	Piston A_1 cm ²	Area Rod A_2 cm ²	Annulus A_3 cm ²	Force at 250 bar ¹⁾			Flow at 0.1 m/s ²⁾		
						Pressure F_1 kN	Diff. F_2 kN	Pulling F_3 kN	Out q_{V1} L/min	Diff. q_{V2} L/min	In q_{V3} L/min
40	25	1.64	12.56	4.90	7.65	31.40	12.25	19.12	7.5	2.9	4.6
	28	1.96		6.16	6.40		15.40	16.00		3.7	3.8
50	32	1.69	19.63	8.04	11.59	49.10	20.12	28.98	11.8	4.8	7.0
	36	2.08		10.18	9.45		25.45	23.65		6.1	5.7
63	40	1.67	31.17	12.56	18.61	77.90	31.38	46.52	18.7	7.5	11.2
	45	2.04		15.90	15.27		39.75	38.15		9.5	9.2
80	50	1.66	50.26	19.63	30.63	125.65	49.07	76.58	30.2	11.8	18.4
	56	1.96		24.63	25.63		61.55	64.10		14.8	15.4
100	63	1.66	78.54	31.16	47.38	196.35	77.93	118.42	47.1	18.7	28.4
	70	1.96		38.48	40.06		96.20	100.15		23.1	24.0
125	80	1.69	122.72	50.24	72.48	306.75	125.62	181.13	73.6	30.14	43.46
	90	2.08		63.62	59.10		159.05	147.70		38.2	35.4
140	90	1.70	153.94	63.62	90.32	384.75	159.05	225.70	92.4	38.2	54.2
	100	2.04		78.54	75.40		196.35	188.40		47.1	45.3
160	100	1.64	201.06	78.54	122.50	502.50	196.35	306.15	120.6	47.1	73.5
	110	1.90		95.06	106.00		237.65	264.85		57.0	63.6
180	110	1.60	254.47	95.06	159.43	636.17	237.65	398.52	152.7	57.0	95.7
	125	1.93		122.72	131.75		306.80	329.37		73.6	79.1
200	125	1.64	314.16	122.72	191.44	785.25	306.80	478.45	188.5	73.6	114.9
	140	1.96		153.96	160.20		384.90	400.35		92.4	96.1
220	140	1.68	380.1	153.9	226.2	950.3	384.8	565.5	228.1	92.4	135.7
	160	2.12		201.0	179.1		502.6	447.7		120.7	107.4
250	160	1.69	499.8	201.0	289.8	1227.2	502.7	724.5	294.5	120.7	173.8
	180	2.08		254.4	236.4		636.2	590.0		152.7	141.8
280	180	1.70	615.7	254.4	361.3	1539.4	636.2	903.2	369.4	152.7	216.7
	200	2.04		314.1	301.6		785.4	753.9		188.5	180.9
320	200	1.64	804.2	314.1	490.1	2010.6	785.4	1225.2	482.5	188.5	294.0
	220	1.90		380.1	424.2		950.3	1060.3		228.1	254.4

Notes

1) Theoretical force (efficiency not taken into account)

2) Stroke velocity

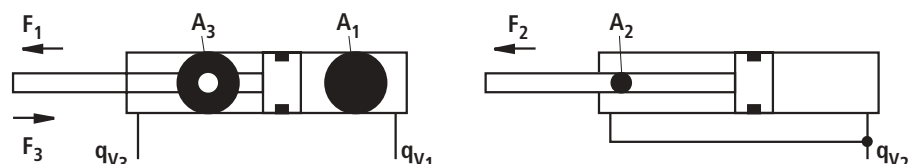

Cylinder weight

Piston	Piston rod	CD cylinder at 0 mm stroke length					Per 100 mm stroke length	CG cylinder at 0 mm stroke length			Per 100 mm stroke length
		AL	MM	MP3 MP5 1)	MP3 MP5 2)	MF3 MF4		MT4	MS2	MF3	
∅	∅	kg	kg	kg	kg	kg	kg	kg	kg	kg	kg
40	25	7	12	9	9	9	0.9	10	10	10	1.3
	28	7	12	9	9	9	1.0	10	10	10	1.5
50	32	12	19.5	14	13	13	1.3	16	16	16	1.9
	36	12	19.5	14	13	14	1.5	16	16	16	2.3
63	40	20	29.5	21	21	21	2.3	25	25	25	3.3
	45	20	29.5	21	21	21	2.6	25	25	25	3.8
80	50	32	42.5	35	34	35	3.2	41	40	41	4.7
	56	32	42.5	35	34	36	3.6	41	40	42	5.5
100	63	51	64.5	54	54	55	5.2	63	63	64	7.6
	70	51	64.5	55	54	56	5.7	64	64	65	8.8
125	80	95	114	96	99	98	8.2	113	115	114	12.1
	90	96	115	97	100	99	9.2	115	117	116	14.2
140	90	131	157	132	136	137	10.7	155	158	159	15.7
	100	132	158	133	137	138	11.9	156	160	161	18.1
160	100	185	220	184	197	206	12.6	217	231	239	18.8
	110	186	221	186	199	207	13.9	220	233	242	21.4
180	110	255	303	253	264	274	14.7	294	305	314	22.1
	125	258	304	256	267	277	16.8	300	311	320	26.5
200	125	349	405	332	350	363	19.0	359	377	389	28.6
	140	352	406	335	353	366	21.5	365	383	396	33.5
220	140	527	625	512	546	518	27.1	604	638	610	39.1
	160	527	625	512	546	518	30.9	604	638	610	46.7
250	160	673	795	640	677	650	32.7	761	798	772	48.5
	180	673	795	640	677	650	36.9	761	798	772	56.9
280	180	976	1192	966	1020	918	44.2	1130	1183	1081	64.2
	200	976	1192	966	1020	918	48.8	1130	1183	1081	73.4
320	200	1251	1512	1172	1223	1174	55.2	1354	1405	1356	79.8
	220	1251	1512	1172	1223	1174	60.4	1354	1405	1356	90.2

Notes

- 1) = Weights without position measuring system
 2) = Weights with position measuring system

Tolerances to ISO 8135

Installation dimensions	WC	XC ²⁾	XO ²⁾	XS ^{1), 2)}	XV ²⁾	ZP ²⁾	Stroke tolerances
Mounting style	MF3	MP3	MP5	MS2	MT4	MF4	
Stroke length	Tolerances						
≤ 1250	± 2	± 1.5	± 1.5	± 2	± 2	± 1.5	+ 2
> 1250 – ≤ 3150	± 4	± 3	± 3	± 4	± 4	± 3	+ 5
> 3150 – ≤ 8000	± 8	± 5	± 5	± 8	± 8	± 5	+ 8

Notes

- 1) Not standardised
 2) Including the stroke length

Mounting style overview

CDH2 MP3

See pages 6, 7

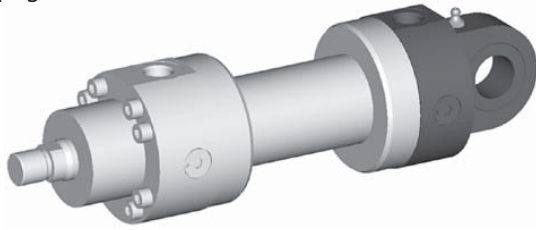

CDH2 MP5

See pages 8, 9

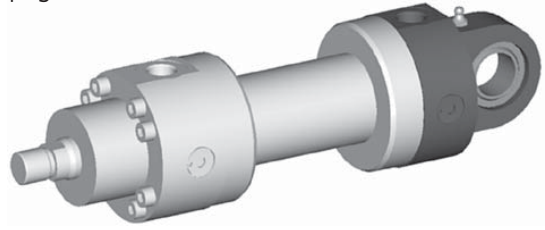

CDH2 MF3

See pages 10, 11

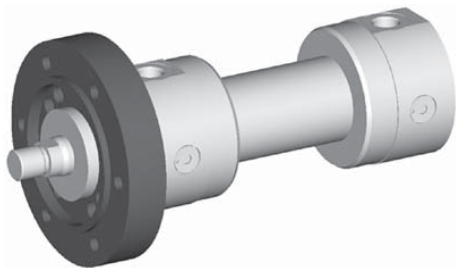

CGH2 MF3

See pages 10, 11

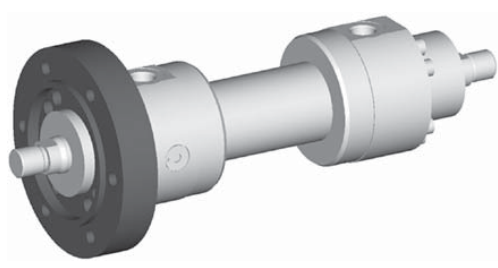

CDH2 MF4

See pages 12, 13

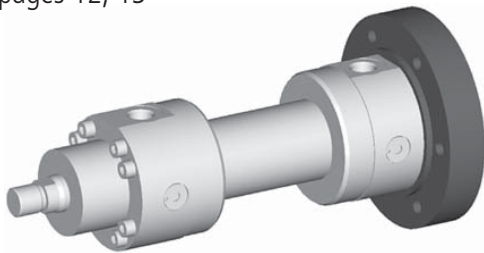

CDH2 MT4

See pages 14, 15

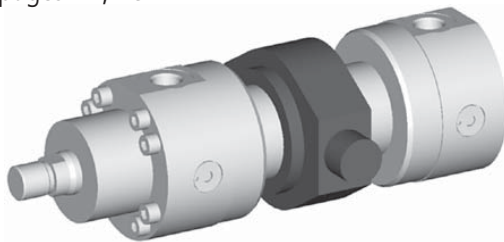

CGH2 MT4

See pages 14, 15

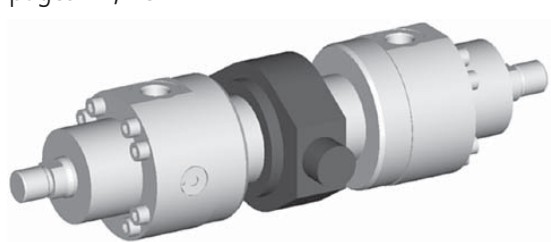

CDH2 MS2

See pages 16, 17

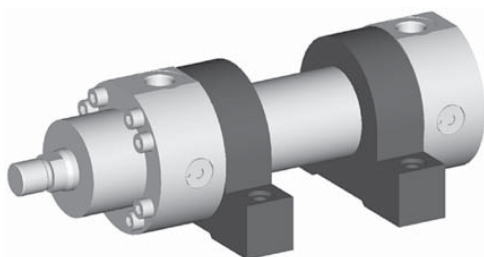

CGH2 MS2

See pages 16, 17

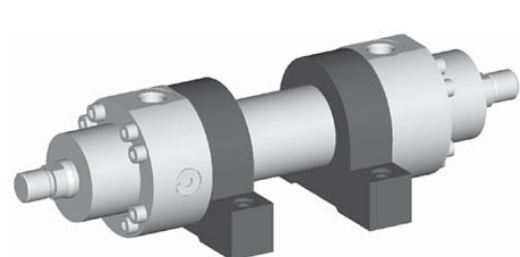

Plain clevis at base MP3

CDH2 MP3

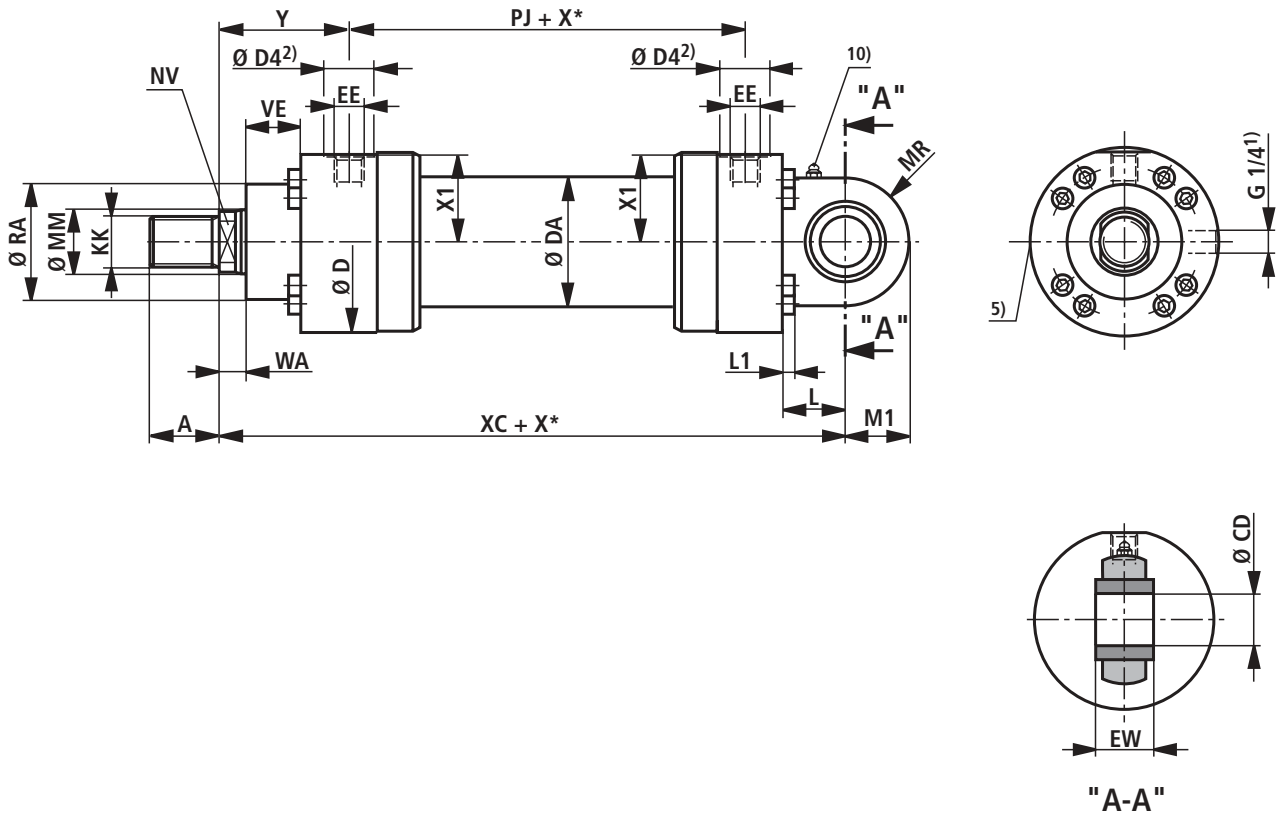

CDH2 MP3: for seal versions „A“, „B“ and AL $\varnothing 160-320$ mm

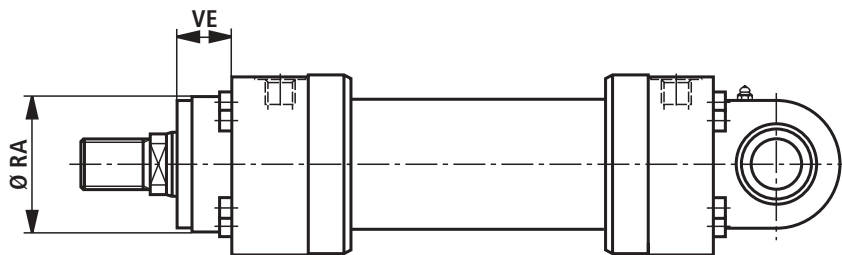

Dimensions MP3 (in mm)

AL Ø	MM Ø	KK	A	NV	D	DA	D4 2)	EE 4)	EE 4)	Y	PJ	X1	WA	XC
40 ⁶⁾	25/28	M20x1.5	28	19/22	88	50	34	G1/2	M22x1.5	83	120	41	18	282
50	32/36	M27x2	36	27/30	102	60	34	G1/2	M22x1.5	98	120	48.5	18	305
63	40/45	M33x2	45	32/36	120	78	42	G3/4	M27x2	112	133	56.5	21	348
80	50/56	M42x2	56	41/46	145	95	42	G3/4	M27x2	120	155	69.5	24	395
100	63/70	M48x2	63	50/60	170	125	47	G1	M33x2	134	171	82	27	442
125	80/90	M64x3	85	65/75	206	150	47	G1	M33x2	153	205	100.5	31	520
140 ⁶⁾	90/100	M72x3	90	75/85	226	170	58	G1 1/4	M42x2	166	219	109.5	31	580
160	100/110	M80x3	95	85/95	265	190	58	G1 1/4	M42x2	185	235	129.5	35	617
180 ⁶⁾	110/125	M90x3	105	95/110	292	210	58	G1 1/4	M42x2	194	264	143.5	40	690
200	125/140	M100x3	112	110/120	306	235	58	G1 1/4	M42x2	220	278	150.5	40	756
220 ⁶⁾	140/160	M125x4	125	120/140	355	270	65	G1 1/2	M48x2 ³⁾	244	326	174	42	890
250	160/180	M125x4	125	140/160	395	305	65	G1 1/2	M48x2 ³⁾	257	326	194	42	903
280 ⁶⁾	180/200	M160x4	160	160/180	445	343	65	G1 1/2	M48x2 ³⁾	290	375	220.5	48	1072
320	200/220	M160x4	160	180/200	490	394	65	G1 1/2	M48x2 ³⁾	282	391	242	48	1080

AL Ø	MM Ø	L	L1	MR	M1	CD H9	EW h12	RA ⁷⁾ f8	VE ⁷⁾	RA ⁸⁾	VE ⁸⁾
40 ⁶⁾	25/28	53	8	32	32	25	25	52	29	88	–
50	32/36	61	8	40	40	32	32	63	29	102	–
63	40/45	74	8	50	50	40	40	75	32	120	–
80	50/56	90	10	63	63	50	50	90	36	145	–
100	63/70	102	12	71	71	63	63	110	41	170	–
125	80/90	124	16	90	90	80	80	132	45	206	–
140 ⁶⁾	90/100	149	16	100	100	90	90	145	45	226	–
160	100/110	150	16	112	112	100	100	160	50	200 ⁹⁾	50
180 ⁶⁾	110/125	180	20	129	129	110	110	185	55	220 ⁹⁾	55
200	125/140	206	20	145	145	125	125	200	61	235 ⁹⁾	61
220 ⁶⁾	140/160	253	20	170	178	160	160	235	71	270	71
250	160/180	253	24	170	178	160	160	250	71	300 ⁹⁾	71
280 ⁶⁾	180/200	320	30	220	230	200	200	295	88	325	88
320	200/220	320	30	220	230	200	200	320	88	365 ⁹⁾	88

Notes

AL = Piston Ø

MM = Piston rod Ø

X* = Stroke length

Stroke and overall length tolerances to ISO 8135

1) = Bleeding: When viewed on the piston rod the orientation is always off-set by 90° to the pipe connection (in a clockwise direction)

2) = Ø D4 max. 0.5 mm deep

3) = M50x2 available on request

4) = For flange connections see separate table on pages 18 and 19

5) = Throttle valve only with end position damping "E" (180° to the bleed point)

6) = Piston Ø not standard

7) = Dimension for cylinder with seal versions M, T and S

8) = Dimension for cylinder with seal versions A and B

9) = Tolerance: f8

10) = Grease nipple; cone head form A to DIN 71 412

11) = Associated pin Ø r6

Self-aligning clevis at base MP5

CDH2 MP5

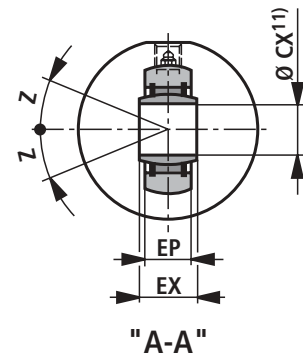
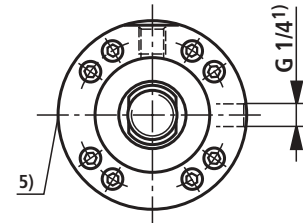
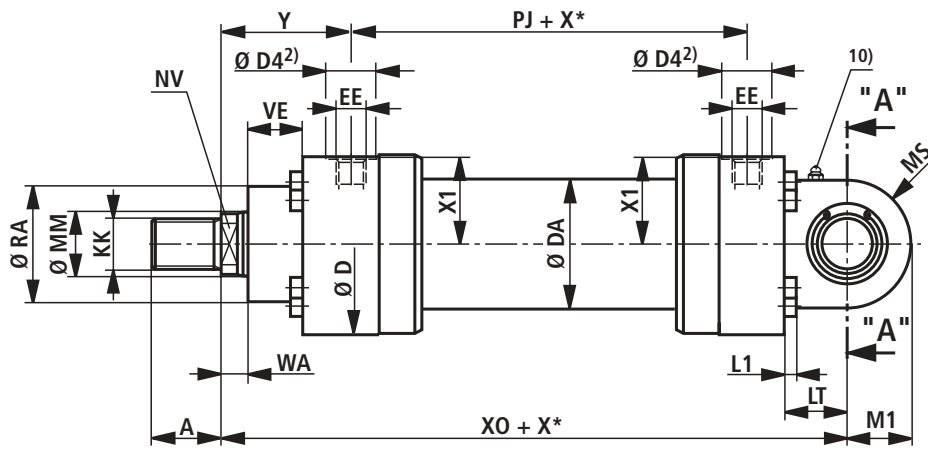

CDH2 MP5: for seal versions „A“, „B“ and AL \varnothing 160-320 mm

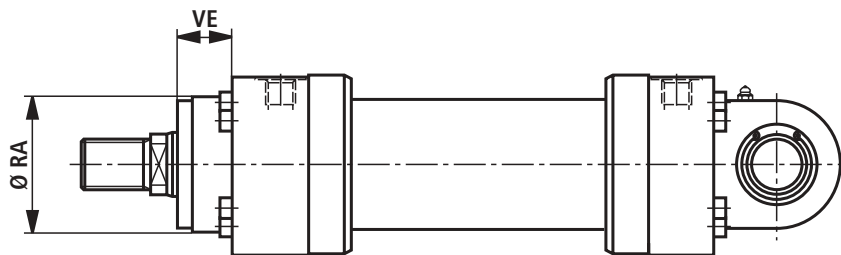

Dimensions MP5 (in mm)

AL Ø	MM Ø	KK	A	NV	D	DA	D4 2)	EE 4)	EE 4)	Y	PJ	X1	WA	XO
40 ⁶⁾	25/28	M20x1.5	28	19/22	88	50	34	G1/2	M22x1.5	83	120	41	18	282
50	32/36	M27x2	36	27/30	102	60	34	G1/2	M22x1.5	98	120	48.5	18	305
63	40/45	M33x2	45	32/36	120	78	42	G3/4	M27x2	112	133	56.5	21	348
80	50/56	M42x2	56	41/46	145	95	42	G3/4	M27x2	120	155	69.5	24	395
100	63/70	M48x2	63	50/60	170	125	47	G1	M33x2	134	171	82	27	442
125	80/90	M64x3	85	65/75	206	150	47	G1	M33x2	153	205	100.5	31	520
140 ⁶⁾	90/100	M72x3	90	75/85	226	170	58	G1 1/4	M42x2	166	219	109.5	31	580
160	100/110	M80x3	95	85/95	265	190	58	G1 1/4	M42x2	185	235	129.5	35	617
180 ⁶⁾	110/125	M90x3	105	95/110	292	210	58	G1 1/4	M42x2	194	264	143.5	40	690
200	125/140	M100x3	112	110/120	306	235	58	G1 1/4	M42x2	220	278	150.5	40	756
220 ⁶⁾	140/160	M125x4	125	120/140	355	270	65	G1 1/2	M48x2 ³⁾	244	326	174	42	890
250	160/180	M125x4	125	140/160	395	305	65	G1 1/2	M48x2 ³⁾	257	326	194	42	903
280 ⁶⁾	180/200	M160x4	160	160/180	445	343	65	G1 1/2	M48x2 ³⁾	290	375	220.5	48	1072
320	200/220	M160x4	160	180/200	490	394	65	G1 1/2	M48x2 ³⁾	282	391	242	48	1080

AL Ø	MM Ø	LT	L1	MS	M1	CX ¹¹⁾ H7	EP	EX h12	RA ⁷⁾ f8	VE ⁷⁾	RA ⁸⁾	VE ⁸⁾	Z
40 ⁶⁾	25/28	53	8	32	32	25	23	25	52	29	88	–	1°
50	32/36	61	8	40	40	32	27	32	63	29	102	–	4°
63	40/45	74	8	50	50	40	32	40	75	32	120	–	4°
80	50/56	90	10	63	63	50	40	50	90	36	145	–	4°
100	63/70	102	12	71	71	63	52	63	110	41	170	–	4°
125	80/90	124	16	90	90	80	66	80	132	45	206	–	4°
140 ⁶⁾	90/100	149	16	100	100	90	72	90	145	45	226	–	4°
160	100/110	150	16	112	112	100	84	100	160	50	200 ⁹⁾	50	4°
180 ⁶⁾	110/125	180	20	129	129	110	88	110	185	55	220 ⁹⁾	55	4°
200	125/140	206	20	145	145	125	102	125	200	61	235 ⁹⁾	61	4°
220 ⁶⁾	140/160	253	20	170	178	160	130	160	235	71	270	71	4°
250	160/180	253	24	170	178	160	130	160	250	71	300 ⁹⁾	71	4°
280 ⁶⁾	180/200	320	30	220	230	200	138	200	295	88	325	88	4°
320	200/220	320	30	220	230	200	162	200	320	88	365 ⁹⁾	88	4°

Notes

AL = Piston Ø

MM = Piston rod Ø

X* = Stroke length

Stroke and overall length tolerances to ISO 8135

1) = Bleeding: When viewed on the piston rod the orientation is always off-set by 90° to the pipe connection (in a clockwise direction)

2) = Ø D4 max. 0.5 mm deep

3) = M50x2 available on request

4) = For flange connections see separate table on pages 18 and 19

5) = Throttle valve only with end position cushioning version "E" (180° to the bleed point)

6) = Piston Ø not standardised

7) = Dimension for cylinder with seal versions M, T and S

8) = Dimension for cylinder with seal versions A and B

9) = Tolerance: f8

10) = Grease nipple; cone head form A to DIN 71 412

11) = Associated pin Ø r6

Round flange at head MF3

CDH2 MF3

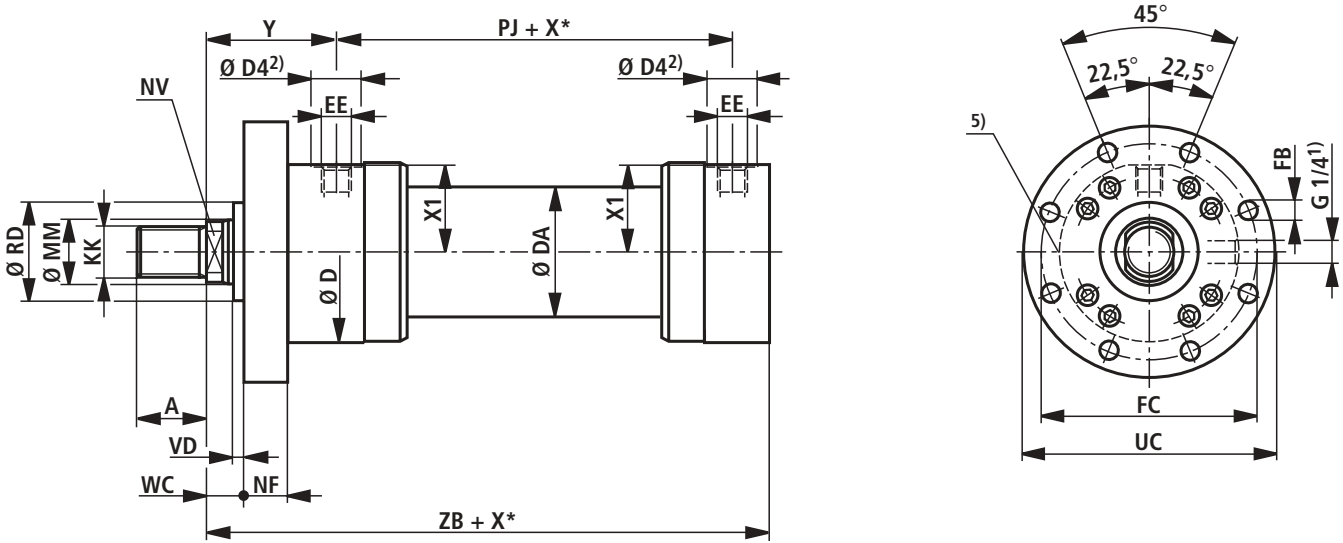

CGH2 MF3¹⁰⁾

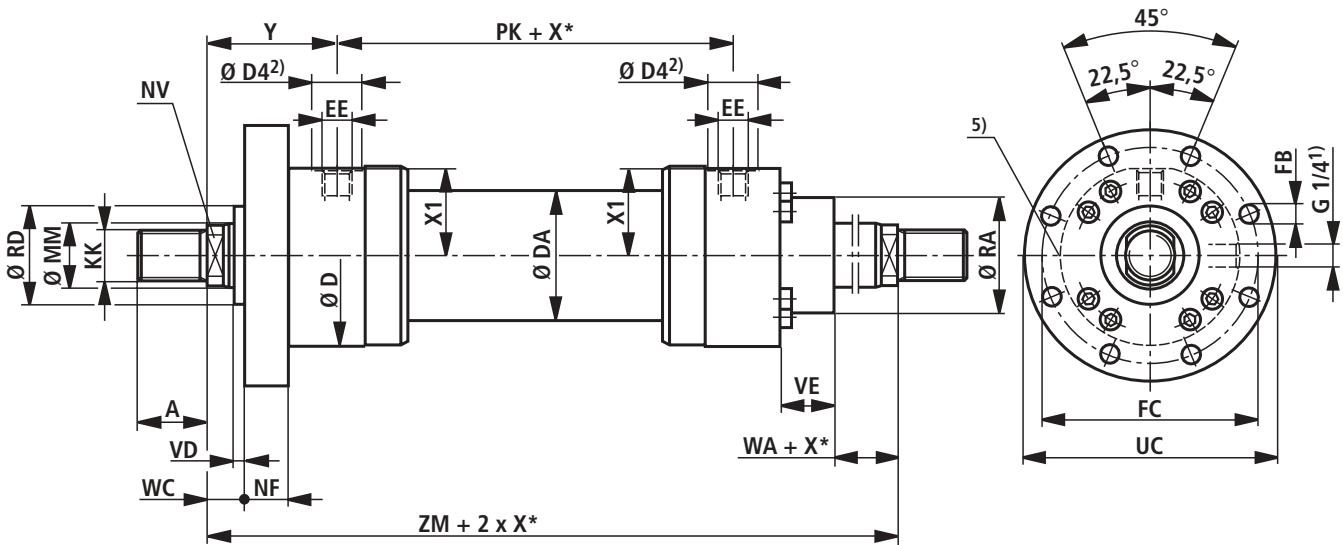

CGH2 MF3¹⁰⁾: for seal versions „A“, „B“ and AL $\text{Ø } 160\text{-}320 \text{ mm}$

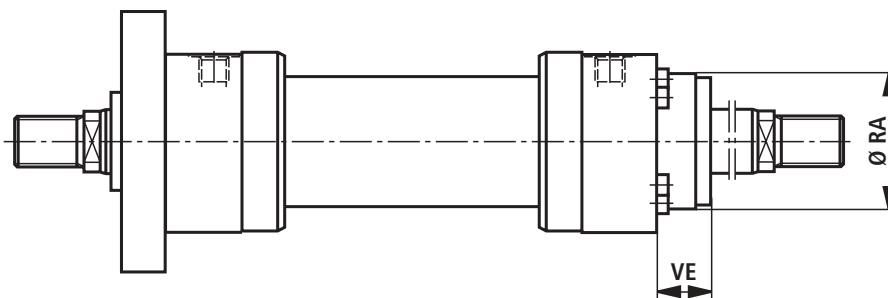

Dimensions MF3 (in mm)

AL Ø	MM Ø	KK	A	NV	D	DA	D4 2)	EE 4)	EE 4)	Y	PJ	X1	WA
40 ⁶⁾	25/28	M20x1.5	28	19/22	88	50	34	G1/2	M22x1.5	83	120	41	18
50	32/36	M27x2	36	27/30	102	60	34	G1/2	M22x1.5	98	120	48.5	18
63	40/45	M33x2	45	32/36	120	78	42	G3/4	M27x2	112	133	56.5	21
80	50/56	M42x2	56	41/46	145	95	42	G3/4	M27x2	120	155	69.5	24
100	63/70	M48x2	63	50/60	170	125	47	G1	M33x2	134	171	82	27
125	80/90	M64x3	85	65/75	206	150	47	G1	M33x2	153	205	100.5	31
140 ⁶⁾	90/100	M72x3	90	75/85	226	170	58	G1 1/4	M42x2	166	219	109.5	31
160	100/110	M80x3	95	85/95	265	190	58	G1 1/4	M42x2	185	235	129.5	35
180 ⁶⁾	110/125	M90x3	105	95/110	292	210	58	G1 1/4	M42x2	194	264	143.5	40
200	125/140	M100x3	112	110/120	306	235	58	G1 1/4	M42x2	220	278	150.5	40
220 ⁶⁾	140/160	M125x4	125	120/140	355	270	65	G1 1/2	M48x2 ³⁾	244	326	174	42
250	160/180	M125x4	125	140/160	395	305	65	G1 1/2	M48x2 ³⁾	257	326	194	42
280 ⁶⁾	180/200	M160x4	160	160/180	445	343	65	G1 1/2	M48x2 ³⁾	290	375	220.5	48
320	200/220	M160x4	160	180/200	490	394	65	G1 1/2	M48x2 ³⁾	282	391	242	48

AL Ø	MM Ø	RD f8	WC	VD	NF js13	PK	ZB max.	ZM	FB H13	FC js13	UC Ø-1	RA ⁷⁾ f8	VE ⁷⁾	RA ⁸⁾	VE ⁸⁾
40 ⁶⁾	25/28	52	22	4	25	120	230	286	11	115	138	52	29	88	–
50	32/36	63	22	4	25	120	244	316	13,5	132	155	63	29	102	–
63	40/45	75	25	4	28	133	274	357	13,5	150	175	75	32	120	–
80	50/56	90	28	4	32	155	305	395	17,5	180	210	90	36	145	–
100	63/70	110	32	5	36	171	340	439	22	212	250	110	41	170	–
125	80/90	132	36	5	40	205	396	511	22	250	290	132	45	206	–
140 ⁶⁾	90/100	145	36	5	40	219	430	551	26	280	325	145	45	226	–
160	100/110	160	40	5	45	235	467	605	26	315	360	160	50	200 ⁹⁾	50
180 ⁶⁾	110/125	185	45	5	50	264	510	652	33	350	405	185	55	220 ⁹⁾	55
200	125/140	200	45	5	56	278	550	718	33	385	440	200	61	235 ⁹⁾	61
220 ⁶⁾	140/160	235	50	8	63	326	637	814	39	435	500	235	71	270	71
250	160/180	250	50	8	63	326	650	840	38	475	540	250	71	300 ⁹⁾	71
280 ⁶⁾	180/200	295	56	8	80	375	752	955	45	555	630	295	88	325	88
320	200/220	320	56	8	80	391	760	955	45	600	675	320	88	365 ⁹⁾	88

Notes

AL = Piston Ø

MM = Piston rod Ø

X* = Stroke length

Stroke and overall length tolerances to ISO 8135

1) = Bleeding: When viewed on the piston rod the orientation is always off-set by 90° to the pipe connection (in a clockwise direction)

2) = Ø D4 max. 0.5 mm deep

3) = M50x2 available on request

4) = For flange connections see separate table on pages 18 and 19

5) = Throttle valve only with end position damping "E" (180° to the bleed point)

6) = Piston Ø not standardised

7) = Dimension for cylinder with seal versions M, T and S

8) = Dimension for cylinder with seal versions A and B

9) = Tolerance: f8

10) = Double roded cylinders are not standardised

Round flange at base MF4

CDH2 MF4

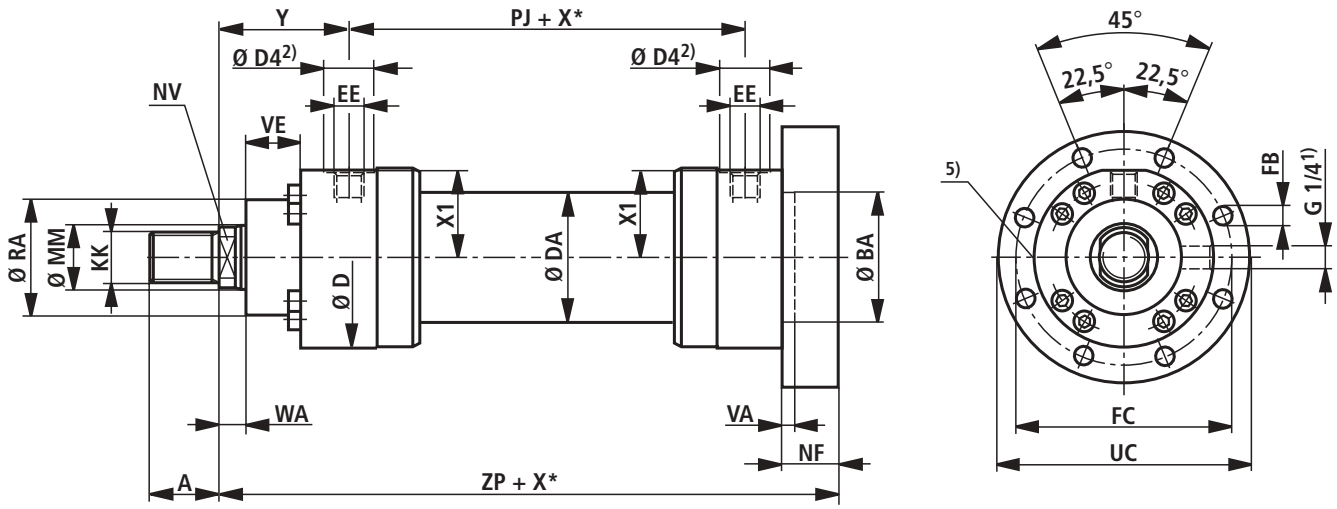

CDH2 MF4: for seal versions „A“, „B“ and AL Ø 160-320 mm

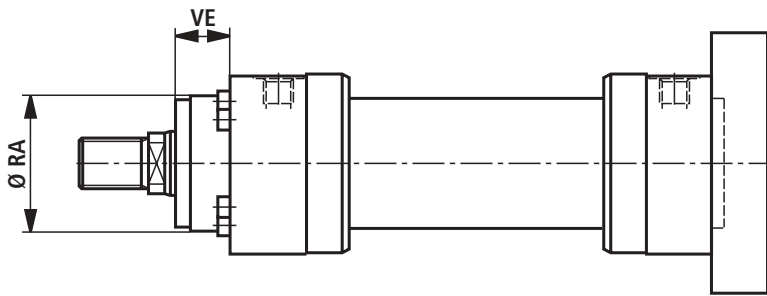

Dimensions MF4 (in mm)

AL Ø	MM Ø	KK	A	NV	D	DA	D4 2)	EE 4)	EE 4)	Y	PJ	X1	WA
40 ⁶⁾	25/28	M20x1.5	28	19/22	88	50	34	G1/2	M22x1.5	83	120	41	18
50	32/36	M27x2	36	27/30	102	60	34	G1/2	M22x1.5	98	120	48.5	18
63	40/45	M33x2	45	32/36	120	78	42	G3/4	M27x2	112	133	56.5	21
80	50/56	M42x2	56	41/46	145	95	42	G3/4	M27x2	120	155	69.5	24
100	63/70	M48x2	63	50/60	170	125	47	G1	M33x2	134	171	82	27
125	80/90	M64x3	85	65/75	206	150	47	G1	M33x2	153	205	100.5	31
140 ⁶⁾	90/100	M72x3	90	75/85	226	170	58	G1 1/4	M42x2	166	219	109.5	31
160	100/110	M80x3	95	85/95	265	190	58	G1 1/4	M42x2	185	235	129.5	35
180 ⁶⁾	110/125	M90x3	105	95/110	292	210	58	G1 1/4	M42x2	194	264	143.5	40
200	125/140	M100x3	112	110/120	306	235	58	G1 1/4	M42x2	220	278	150.5	40
220 ⁶⁾	140/160	M125x4	125	120/140	355	270	65	G1 1/2	M48x2 ³⁾	244	326	174	42
250	160/180	M125x4	125	140/160	395	305	65	G1 1/2	M48x2 ³⁾	257	326	194	42
280 ⁶⁾	180/200	M160x4	160	160/180	445	343	65	G1 1/2	M48x2 ³⁾	290	375	220.5	48
320	200/220	M160x4	160	180/200	490	394	65	G1 1/2	M48x2 ³⁾	282	391	242	48

AL Ø	MM Ø	ZP	NF js13	VA	BA H8	FB H13	FC js13	UC Ø-1	RA ⁷⁾ f8	VE ⁷⁾	RA ⁸⁾	VE ⁸⁾
40 ⁶⁾	25/28	250	25	5	52	11	115	138	52	29	88	–
50	32/36	265	25	4	63	13,5	132	155	63	29	102	–
63	40/45	298	28	4	75	13,5	150	175	75	32	120	–
80	50/56	332	32	5	90	17,5	180	210	90	36	145	–
100	63/70	371	36	5	110	22	212	250	110	41	170	–
125	80/90	430	40	6	132	22	250	290	132	45	206	–
140 ⁶⁾	90/100	465	40	5	145	26	280	325	145	45	226	–
160	100/110	505	45	7	160	26	315	360	160	50	200 ⁹⁾	50
180 ⁶⁾	110/125	550	50	10	185	33	350	405	185	55	220 ⁹⁾	55
200	125/140	596	56	10	200	33	385	440	200	61	235 ⁹⁾	61
220 ⁶⁾	140/160	690	63	10	235	39	435	500	235	71	270	71
250	160/180	703	63	10	250	39	475	540	250	71	300 ⁹⁾	71
280 ⁶⁾	180/200	822	80	10	295	45	555	630	295	88	325	88
320	200/220	830	80	10	320	45	600	675	320	88	365 ⁹⁾	88

Notes

AL = Piston Ø

MM = Piston rod Ø

X* = Stroke length

Stroke and overall length tolerances to ISO 8135

1) = Bleeding: When viewed on the piston rod, the orientation is always off-set by 90° to the pipe connection (in a clockwise direction)

2) = Ø D4 max. 0.5 mm deep

3) = M50x2 available on request

4) = For flange connections see separate table on pages 18 and 19

5) = Throttle valve only with end position damping "E" (180° to the bleed point)

6) = Piston Ø non standardised

7) = Dimension for cylinder with seal versions M, T and S

8) = Dimension for cylinder with seal versions A and B

9) = Tolerance: f8

Trunnions MT4

CDH2 MT4

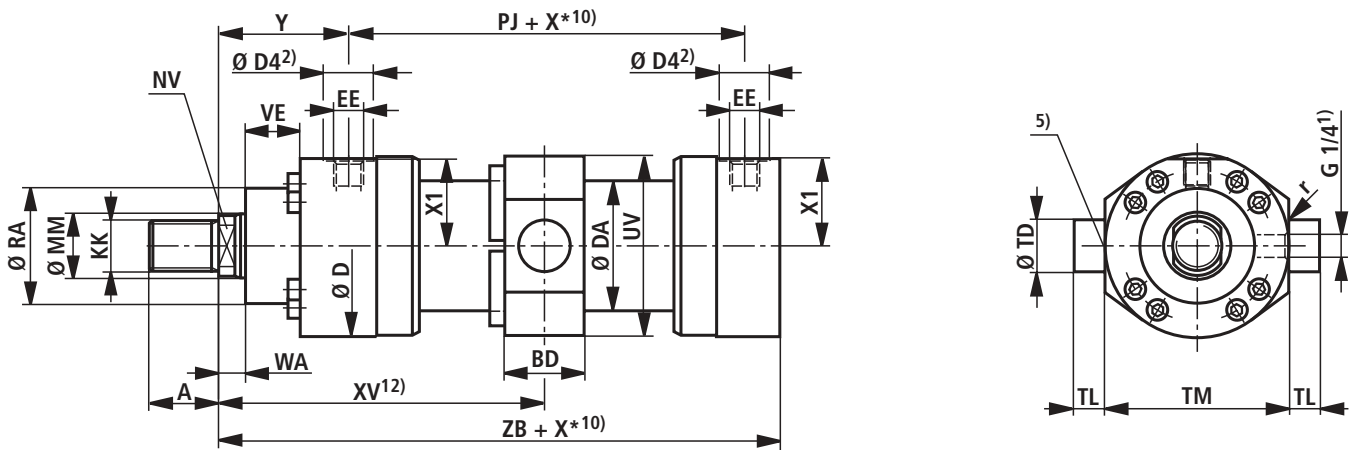

CDH2 MT4: for seal versions „A”, „B” and AL Ø 160-320 mm

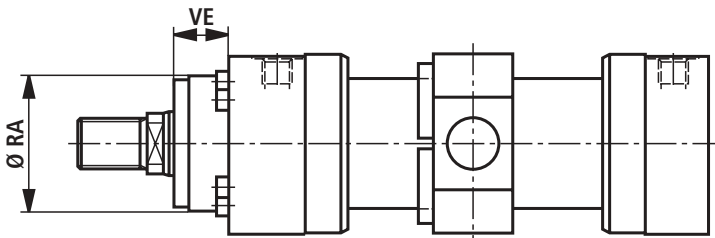

CGH2 MT4¹¹⁾

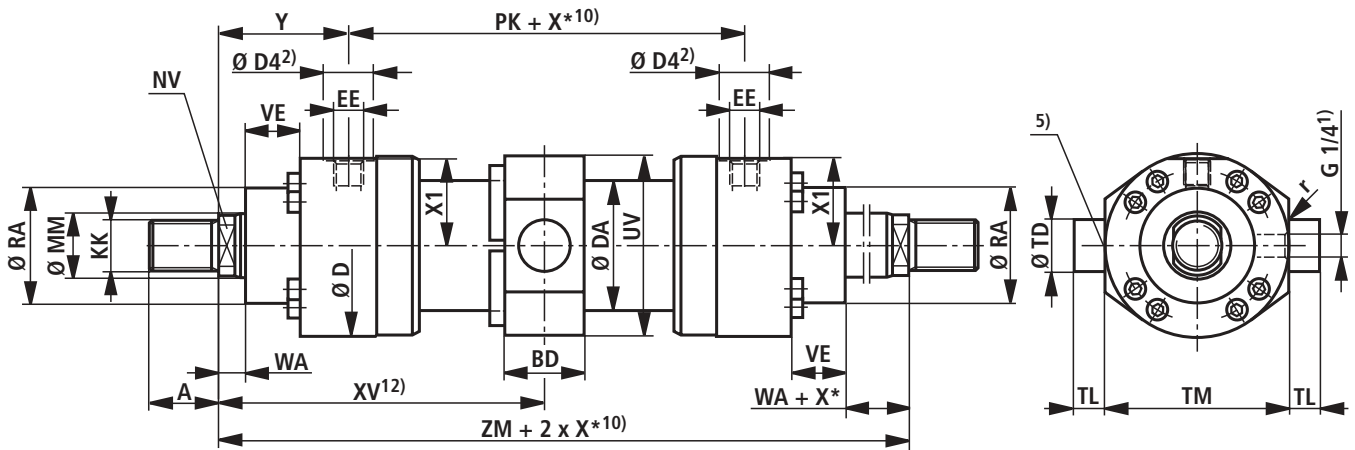

CGH2 MT4¹¹⁾: for seal versions „A”, „B” and AL Ø 160-320 mm

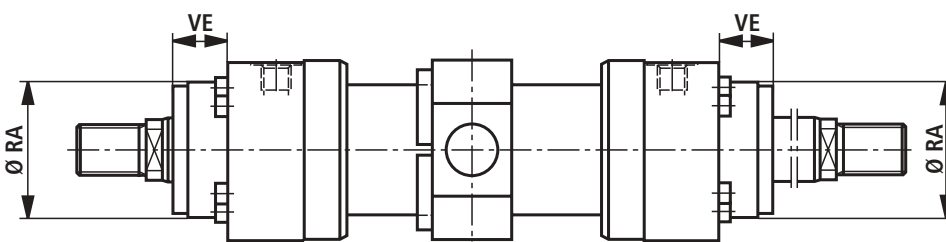

Dimensions MT4 (in mm)

AL Ø	MM Ø	KK	A	NV	D	DA	D4 2)	EE 4)	EE 4)	Y	PJ	X1	WA
40 ⁶⁾	25/28	M20x1.5	28	19/22	88	50	34	G1/2	M22x1.5	83	120	41	18
50	32/36	M27x2	36	27/30	102	60	34	G1/2	M22x1.5	98	120	48.5	18
63	40/45	M33x2	45	32/36	120	78	42	G3/4	M27x2	112	133	56.5	21
80	50/56	M42x2	56	41/46	145	95	42	G3/4	M27x2	120	155	69.5	24
100	63/70	M48x2	63	50/60	170	125	47	G1	M33x2	134	171	82	27
125	80/90	M64x3	85	65/75	206	150	47	G1	M33x2	153	205	100.5	31
140 ⁶⁾	90/100	M72x3	90	75/85	226	170	58	G1 1/4	M42x2	166	219	109.5	31
160	100/110	M80x3	95	85/95	265	190	58	G1 1/4	M42x2	185	235	129.5	35
180 ⁶⁾	110/125	M90x3	105	95/110	292	210	58	G1 1/4	M42x2	194	264	143.5	40
200	125/140	M100x3	112	110/120	306	235	58	G1 1/4	M42x2	220	278	150.5	40
220 ⁶⁾	140/160	M125x4	125	120/140	355	273	65	G1 1/2	M48x2 ³⁾	244	326	174	42
250	160/180	M125x4	125	140/160	395	305	65	G1 1/2	M48x2 ³⁾	257	326	194	42
280 ⁶⁾	180/200	M160x4	160	160/180	445	343	65	G1 1/2	M48x2 ³⁾	290	375	220.5	48
320	200/220	M160x4	160	180/200	490	394	65	G1 1/2	M48x2 ³⁾	282	391	242	48

AL Ø	MM Ø	PK	ZB max.	ZM	X* min.	XV ¹³⁾ mitt	XV ¹²⁾ min.	XV ¹²⁾ max.	BD	UV	TD f8	TL js16	TM h13	r	RA ⁷⁾ f8	VE ⁷⁾	RA ⁸⁾	VE ⁸⁾
40 ⁶⁾	25/28	120	230	286	22	143+X*/2	154	140+X*	38	88	25	20	95	0.8	52	29	88	–
50	32/36	120	244	316	32	158+X*/2	174	151+X*	38	102	32	25	112	0.8	63	29	102	–
63	40/45	133	274	357	47	178.5+X*/2	202	167+X*	48	120	40	32	125	1	75	32	120	–
80	50/56	155	305	395	58	197.5+X*/2	226.5	180.5+X*	58	150	50	40	150	1	90	36	145	–
100	63/70	171	340	439	79	219.5+X*/2	259	195+X*	78	175	63	50	180	1.2	110	41	170	–
125	80/90	205	396	511	91	255.5+X*/2	301	225+X*	98	220	80	63	224	1.2	132	45	206	–
140 ⁶⁾	90/100	219	430	551	121	275.5+X*/2	336	230+X*	118	240	90	70	265	1.5	145	45	226	–
160	100/110	235	467	605	142	302.5+X*/2	373.5	251.5+X*	128	270	100	80	280	1.5	160	50	200 ⁹⁾	50
180 ⁶⁾	110/125	264	510	652	158	326+X*/2	405	267+X*	138	310	110	90	320	1.5	185	55	220 ⁹⁾	55
200	125/140	278	550	718	204	359+X*/2	461	277+X*	178	320	125	100	335	1.5	200	61	235 ⁹⁾	61
220 ⁶⁾	140/160	326	637	814	200	407+X*/2	507	307+X*	180	370	160	125	385	1.5	235	71	270	71
250	160/180	326	650	840	210	420+X*/2	525	315+X*	180	410	160	125	425	1.5	250	71	300 ⁹⁾	71
280 ⁶⁾	180/200	375	752	955	241	477.5+X*/2	598	357+X*	220	460	200	160	480	2	295	88	325	88
320	200/220	391	760	955	245	477.5+X* ¹⁾ / ₂	600	355+X*	220	510	200	160	530	2	320	88	365 ⁹⁾	88

Notes

AL = Piston Ø

MM = Piston rod Ø

X* = Stroke length

Stroke and overall length tolerances to ISO 8135

1) = Bleeding: When viewed on the piston rod, the orientation is always off-set by 90° to the pipe connection (in a clockwise direction)

2) = Ø D4 max. 0.5 mm deep

3) = M50x2 available on request

4) = For flange connections see separate table on pages 18 and 19

5) = Throttle valve only with end position damping "E" (180° to the bleed point)

6) = Piston Ø not standardised

7) = Dimension for cylinder with seal versions M, T and S

8) = Dimension for cylinder with seal versions A and B

9) = Tolerance: f8

10) = Take the minimum stroke length „X*min.“ into account

11) = Double roded cylinders are not standardised

12) = The trunnions can be located as required.

Dim. „XV“ must always be stated in clear text, in the case of an order, in mm.

Take „XVmin.“ and „XVmax.“ into account.

13) = XVmid. recommendation: The trunnions are located in the middle of the cylinder

Foot mounting MS2

CDH2 MS2²⁾

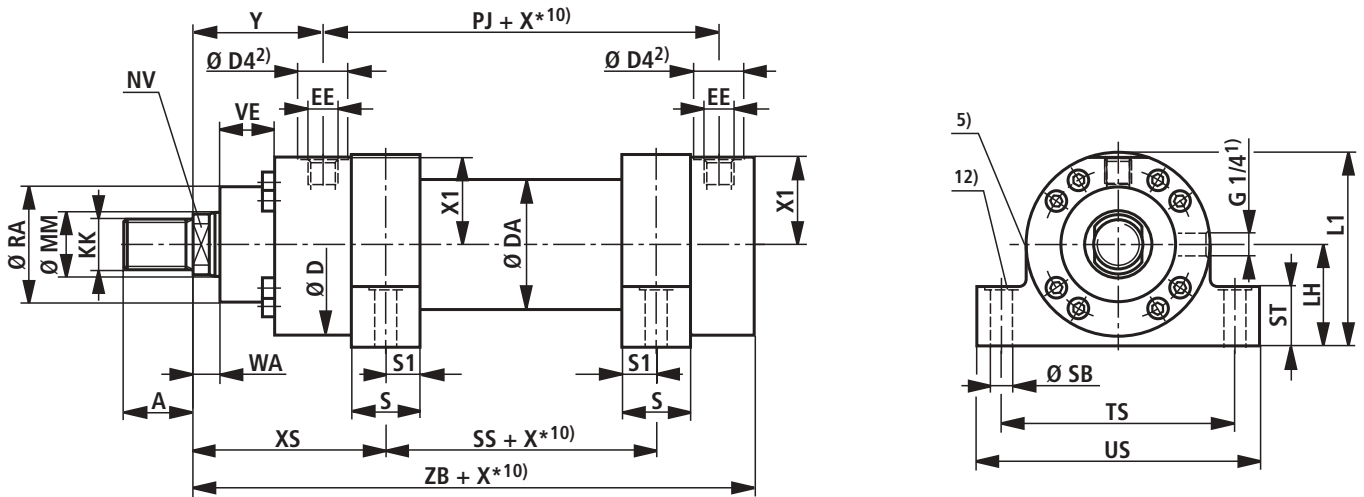

CDH2 MS2: for seal versions „A“, „B“ and AL $\varnothing 160-320$ mm

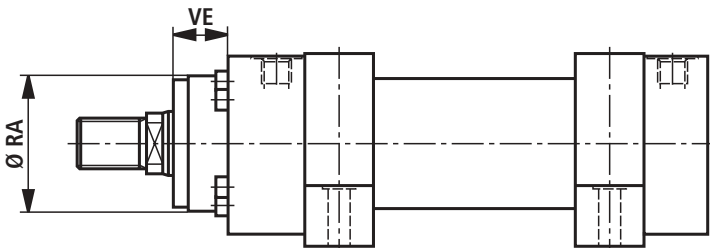

CGH2 MS2¹¹⁾

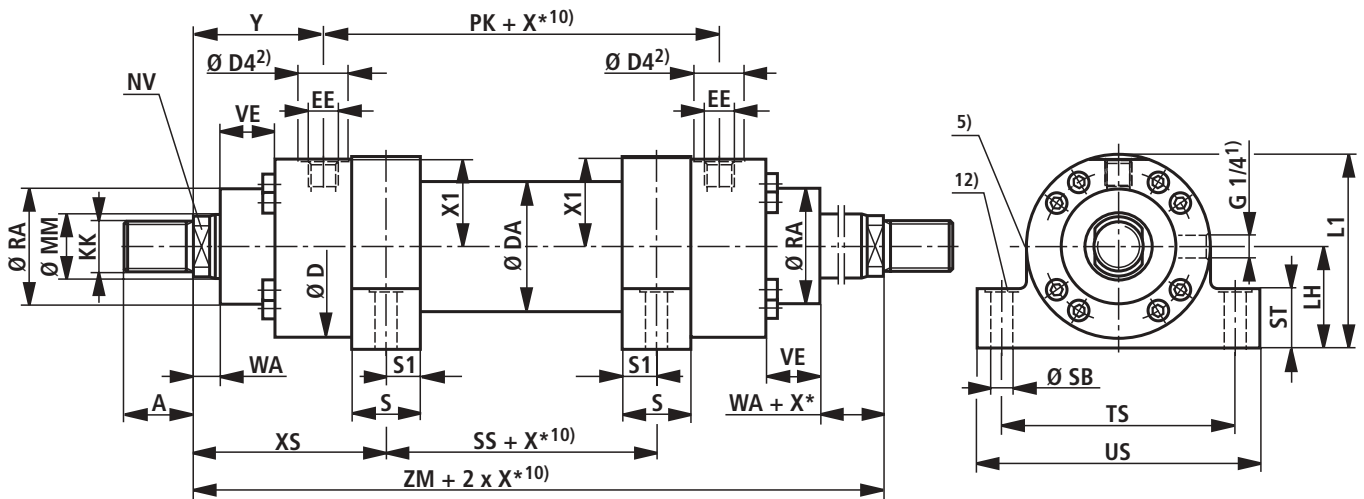

CGH2 MS2¹¹⁾: for seal versions „A“, „B“ and AL $\varnothing 160-320$ mm

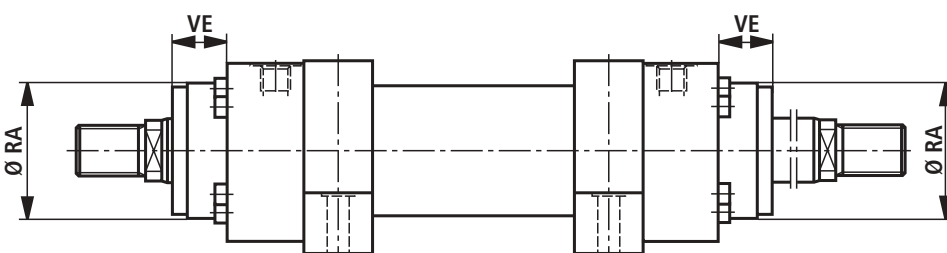

Dimensions MS2 (in mm)

AL Ø	MM Ø	KK	A	NV	D	DA	D4 2)	EE 7)	EE 7)	Y	PJ	X1	WA
40 ⁶⁾	25/28	M20x1.5	28	19/22	88	50	34	G1/2	M22x1.5	83	120	41	18
50	32/36	M27x2	36	27/30	102	60	34	G1/2	M22x1.5	98	120	48.5	18
63	40/45	M33x2	45	32/36	120	78	42	G3/4	M27x2	112	133	56.5	21
80	50/56	M42x2	56	41/46	145	95	42	G3/4	M27x2	120	155	69.5	24
100	63/70	M48x2	63	50/60	170	125	47	G1	M33x2	134	171	82	27
125	80/90	M64x3	85	65/75	206	150	47	G1	M33x2	153	205	100.5	31
140 ⁶⁾	90/100	M72x3	90	75/85	226	170	58	G1 1/4	M42x2	166	219	109.5	31
160	100/110	M80x3	95	85/95	265	190	58	G1 1/4	M42x2	185	235	129.5	35
180 ⁶⁾	110/125	M90x3	105	95/110	292	210	58	G1 1/4	M42x2	194	264	143.5	40
200	125/140	M100x3	112	110/120	306	235	58	G1 1/4	M42x2	220	278	150.5	40
220 ⁶⁾	140/160	M125x4	125	120/140	355	270	65	G1 1/2	M48x2 ³⁾	244	326	174	42
250	160/180	M125x4	125	140/160	395	305	65	G1 1/2	M48x2 ³⁾	257	326	194	42
280 ⁶⁾	180/200	M160x4	160	160/180	445	343	65	G1 1/2	M48x2 ³⁾	290	375	220.5	48
320	200/220	M160x4	160	180/200	490	394	65	G1 1/2	M48x2 ³⁾	282	391	242	48

AL Ø	MM Ø	PK	XS	ZB max.	ZM	SS	X* ¹⁰⁾ min.	S	S1	SB H13	ST	TS js13	US Ø-1	LH	L1	RA ⁷⁾ f8	VE ⁷⁾	RA ⁸⁾	VE ⁸⁾
40 ⁶⁾	25/28	120	118	230	286	50	1	30	15	11	32	110	135	45	89	52	29	88	–
50	32/36	120	135.5	244	316	45	1	35	17.5	11	37	130	155	55	106	63	29	102	–
63	40/45	133	154	274	357	49	1	40	20	13.5	42	150	180	65	125	75	32	120	–
80	50/56	155	171.5	305	395	52	2	50	25	17.5	47	180	220	75	147.5	90	36	145	–
100	63/70	171	189	340	439	61	3	60	30	22	57	210	255	90	175	110	41	170	–
125	80/90	205	218	396	511	75	1	70	35	26	67	255	305	105	208	132	45	206	–
140 ⁶⁾	90/100	219	240.5	430	551	70	19	85	42.5	30	72	290	350	115	228	145	45	226	–
160	100/110	235	270	467	605	65	44	105	52.5	33	77	330	400	135	267.5	160	50	200 ⁹⁾	50
180 ⁶⁾	110/125	264	291.5	510	652	69	50	115	57.5	40	92	360	440	150	296	185	55	220 ⁹⁾	55
200	125/140	278	322.5	550	718	73	56	125	62.5	40	97	385	465	160	313	200	61	235 ⁹⁾	61
220 ⁶⁾	140/160	326	369.5	637	814	75	100	155	77.5	45	102	445	530	185	362.5	235	71	270	71
250	160/180	326	382.5	650	840	75	100	155	77.5	52	112	500	600	205	402.5	250	71	300 ⁹⁾	71
280 ⁶⁾	180/200	375	415.5	752	955	124	51	155	77.5	52	142	550	650	235	457.5	295	88	325	88
320	200/220	391	435	760	955	85	125	190	95	62	142	610	730	255	500	320	88	365 ⁹⁾	88

Notes

AL = Piston Ø

MM = Piston rod Ø

X* = Stroke length

Stroke and overall length tolerances to ISO 8135

1) = Bleeding: When viewed on the piston rod, the orientation is always off-set by 90° to the pipe connection (in a clockwise direction)

2) = Ø D4 max. 0.5 mm deep

3) = M50x2 available on request

4) = For flange connections see separate table on pages 18 and 19

5) = Throttle valve only for end position damping version "E"
(180° to the bleed point)

6) = Piston Ø not standardised

7) = Dimensions for cylinder with seal versions M, T and S

8) = Dimensions for cylinder with seal versions A and B

9) = Tolerance: f8

10) = Take the minimum stroke length „X*min.“ into account

11) = Double roded cylinders are not standardised

12) = 2 mm deep counter bore for the DIN 912 S.H.C.S.

The screws must not be subjected to shear loads. The forces have to be distributed by keys

Flange connections

CDH2: AL-Ø 40-320 mm

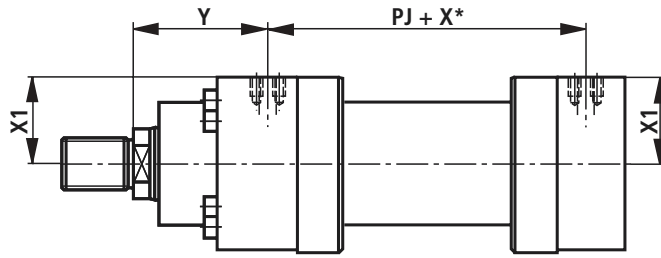

CGH2: AL-Ø 40-320 mm

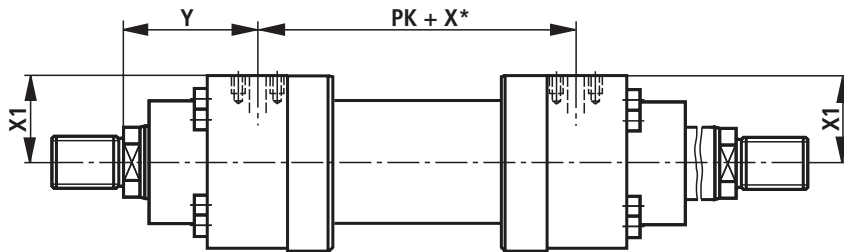

Porting pattern for rectangular flanges to ISO 6162 table 1 (Δ SAE 3000 PSI) and table 2 (Δ SAE 6000 PSI)

Porting pattern for square flanges to ISO 6164 tables 1 and 2

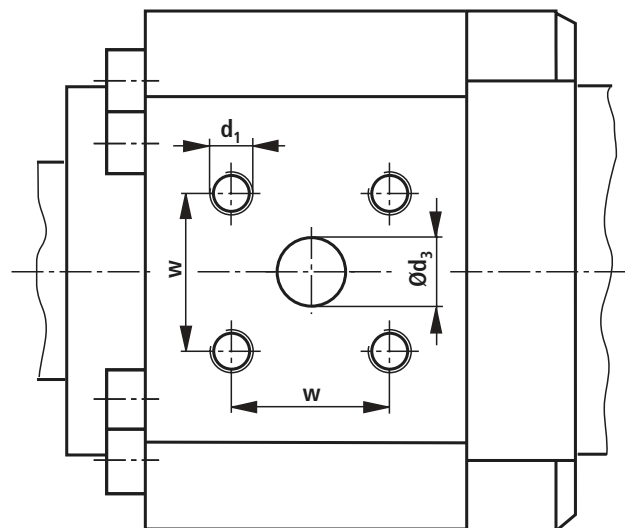
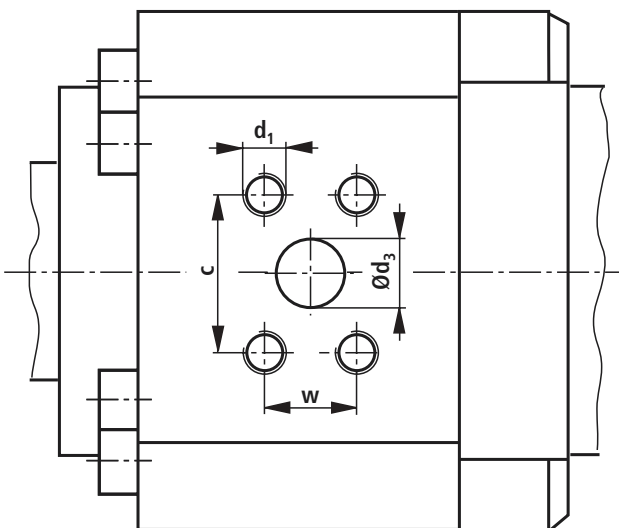

Flange connections (in mm)

AL Ø	ISO 6162 Tab.1 (200 - 350 bar) (Δ SAE 3000 PSI)											ISO 6164 Tab.1 (250 bar)								
	Y	PJ PK	X1	d ₃ Ø	d ₃ ⁽⁴⁾ Ø	c ±0.25	w ±0.25	d ₁	t ₁ ⁽¹⁾	t ₁ ⁽²⁾	p ⁽³⁾	Y	PJ PK	X1	d ₃ Ø	w ±0.25	d ₁	t ₁ ⁽¹⁾	t ₁ ⁽²⁾	p ⁽³⁾
40	–	–	–	–	–	–	–	–	–	–	–	82	122	40.5	10	24.7	M6	12.5	10	250
50	–	–	–	–	–	–	–	–	–	–	–	97	122	48	10	24.7	M6	12.5	12.5	250
63	111	135	54	13	1/2"	38.1	17.5	M8	16	16	350	111	135	57	13	29.7	M8	16	16	250
80	123.5	148	68	13	1/2"	38.1	17.5	M8	16	16	350	123.5	148	69.5	13	29.7	M8	16	16	250
100	133	173	79	19	3/4"	47.6	22.3	M10	20	20	350	133	173	81.5	19	35.4	M8	16	16	250
125	153	205	98	25	1"	52.4	26.2	M10	20	20	350	157	197	100	19	35.4	M8	16	16	250
140	162	227	107	32	1 1/4"	58.7	30.2	M10	20	20	250	162	227	109	25	43.8	M10	20	20	250
160	181.5	242	127	32	1 1/4"	58.7	30.2	M10	20	20	250	181.5	242	128.5	25	43.8	M10	20	20	250
180	193	266	139	38	1 1/2"	69.9	35.7	M12	24	24	200	194	264	142	32	51.6	M12	24	24	250
200	219	280	146.5	38	1 1/2"	69.9	35.7	M12	24	24	200	220	278	148.5	32	51.6	M12	24	24	250

AL Ø	ISO 6162 Tab.2 (400 bar) (Δ SAE 6000 PSI)											ISO 6164 Tab.2 (400 bar)								
	Y	PJ PK	X1	d ₃ Ø	d ₃ ⁽⁵⁾ Ø	c ±0.25	w ±0.25	d ₁	t ₁ ⁽¹⁾	t ₁ ⁽²⁾	p ⁽³⁾	Y	PJ PK	X1	d ₃ Ø	w ±0.25	d ₁	t ₁ ⁽¹⁾	t ₁ ⁽²⁾	p ⁽³⁾
40	–	–	–	–	–	–	–	–	–	–	–	82	122	40.5	10	24.7	M6	12.5	10	400
50	–	–	–	–	–	–	–	–	–	–	–	97	122	48	10	24.7	M6	12.5	12.5	400
63	–	–	–	–	–	–	–	–	–	–	–	111	135	57	13	29.7	M8	16	16	400
80	120	155	67	13	1/2"	40.5	18.2	M8	16	14	400	123.5	148	69.5	13	29.7	M8	16	16	400
100	134	171	80.5	13	1/2"	40.5	18.2	M8	16	16	400	133	173	81.5	19	35.4	M8	16	16	400
125	153	205	97	19	3/4"	50.8	23.8	M10	20	20	400	157	197	100	19	35.4	M8	16	16	400
140	162	227	107	25	1"	57.2	27.8	M12	24	24	400	162	227	109	25	43.8	M10	20	20	400
160	181.5	242	127	25	1"	57.2	27.8	M12	24	24	400	181.5	242	128.5	25	43.8	M10	20	20	400
180	194	264	139.5	32	1 1/4"	66.6	31.8	M14	26	26	400	194	264	142	32	51.6	M12	24	24	400
200	220	278	147	32	1 1/4"	66.6	31.8	M14	26	26	400	220	278	148.5	32	51.6	M12	24	24	400
220	244	326	168	38	1 1/2"	79.3	36.5	M16	30	30	400	244	326	171	38	60.1	M16	30	30	400
250	257	326	189	38	1 1/2"	79.3	36.5	M16	30	30	400	257	326	192	38	60.1	M16	30	30	400
280	290	375	220	38	1 1/2"	79.3	36.5	M16	30	30	400	290	375	223	38	60.1	M16	30	30	400
320	282	391	236	51	2"	98.4	44.5	M20	36	36	400	282	391	240	51	69.3	M16	30	30	400

Notes

For main dimensions see pages 6 to 17

AL = Piston Ø

X* = Stroke length

1) = Thread depth for seal versions M, T and S

2) = Thread depth for seal versions A and B

3) = Max. operating pressure for associated flanges in bar

4) = Flange porting pattern to ISO 6162 Tab.1 relates to a flange porting pattern to SAE 3000 PSI

5) = Flange porting pattern to ISO 6162 Tab.2 relates to a flange porting pattern to SAE 6000 PSI

Position measuring system

MP3, MP5: AL-Ø 40-320 mm

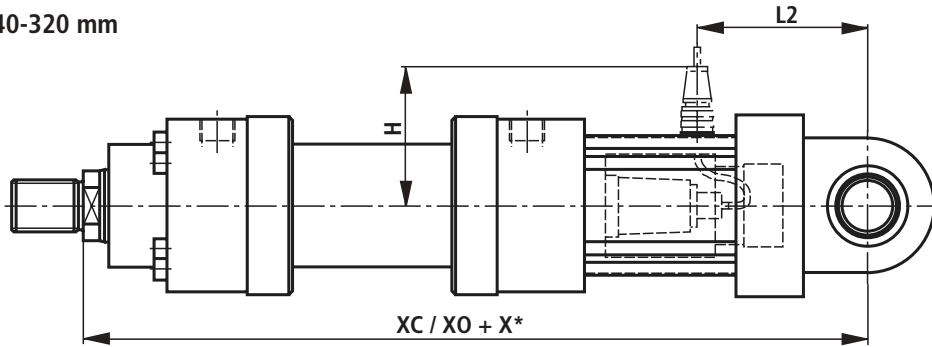

MF3: AL-Ø 40-320 mm

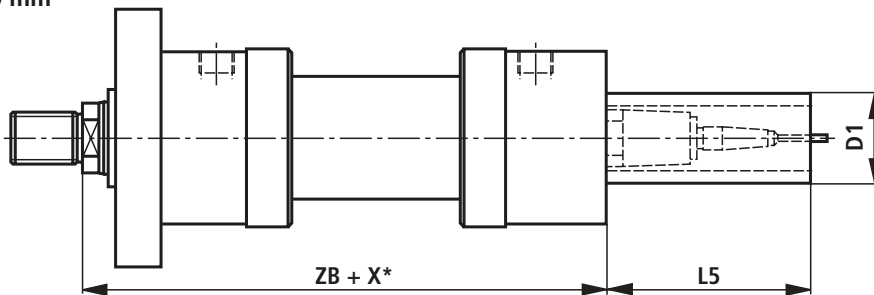

MF4: AL-Ø 40-80 mm

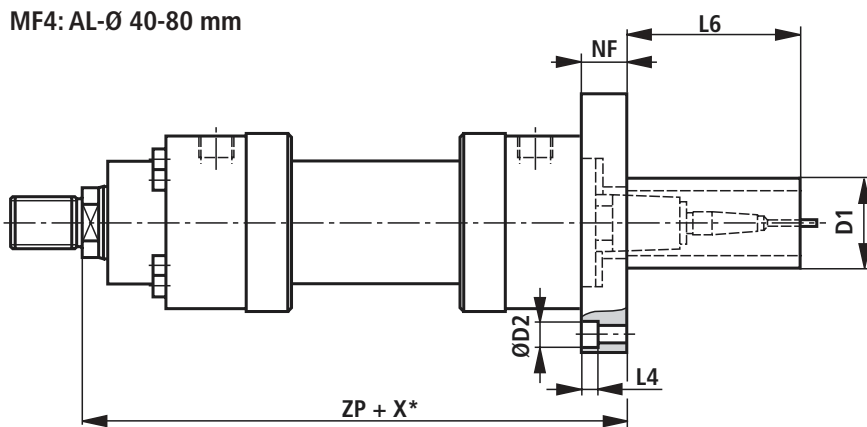

MF4: AL-Ø 100-320 mm

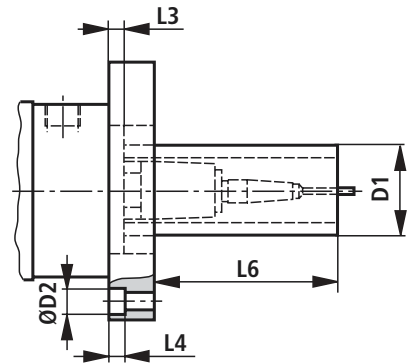

MT4: AL-Ø 40-320 mm

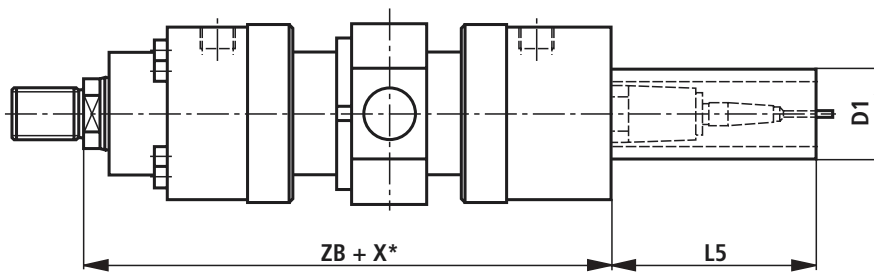

MS2: AL-Ø 40-320 mm

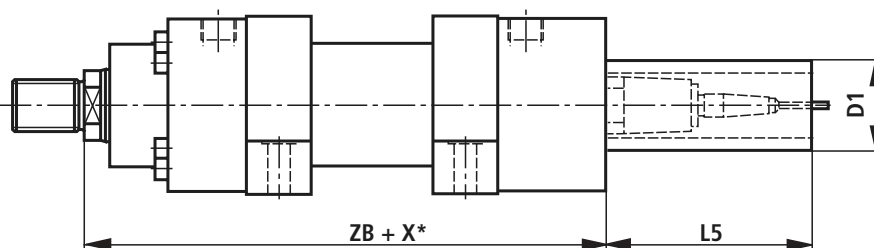

Position measuring system (in mm)

AL Ø	MM Ø	X* _{max}	XC	XO	H	ZB	ZP	NF js13	L2	L3	L4	L5	L6	D1 max	D2 Ø
40	– 28	1400	447	447	115	239	262	28	124	–	3	166	166	80	18
50	32 36	1400	470	470	120	254	278	28	132	–	3	166	166	94	20
63	40 45	2000	526	526	130	299	313	28	150	–	0	166	166	94	0
80	50 56	2000	580	580	125	332.5	350	32	176.5	–	0	166	166	94	0
100	63 70	3000	617	617	135	362	390	36	192	8	0	166	138	94	0
125	80 90	3000	693	693	145	410	445	55	227	20	21.5	166	131	94	33
140	90 100	3000	755	755	155	440	485	60	262	15	25.5	166	121	94	40
160	100 110	3000	787	787	165	472.5	525	65	269.5	12.5	25.5	166	113.5	94	40
180	110 125	3000	855	855	175	510	570	70	307	10	32	166	106	94	48
200	125 140	3000	926	926	190	550	616	76	333	10	32	166	100	94	48
220	140 160	3000	1100	1100	205	637	715	88	418	10	38	166	88	94	57
250	160 180	3000	1115	1115	220	650	730	90	420	10	38	166	86	94	57
280	180 200	3000	1295	1295	280	752	857	115	510	10	44	166	61	94	66
320	200 220	3000	1300	1300	300	760	865	115	520	10	44	166	61	94	66

Notes

For main dimensions see pages 6 to 17

AL = Piston Ø

MM = Piston rod Ø

X* = Stroke length

X*_{max} = Max. stroke length

1) = Centering ring BA cannot be used

Position measuring system

The contactless, absolute position measuring system is rated up to 500 bar. Its function principle is based on the magnetostrictive effect. In connection with this, a torsion impulse is triggered off when two magnetic fields meet. This impulse is directed from the point of measurement via the waveguide inside the measuring scale to the sensor head. The transit time is constant and virtually independent of temperature. It is proportional to the position of the magnet and can therefore be used as a reference for the actual position value and is converted into a direct analogue of digital output in the sensor head.

Technical data

Operating pressure	bar	250
Analogue output	V	0 to 10
	Load resistance	k Ω \geq 5
	Resolution	Continuous
Analogue output	mA	4 to 20
	Load resistance	k Ω \geq 100
	Resolution	Continuous
Digitalausgang		SSI 24 Bit grey coded
	Resolution	μ m 5
Linearity (absolute accuracy)	%	$\leq \pm 0.05$ (referring to the measuring length) min. ± 0.05 mm
Repeatability	%	$\leq \pm 0.001$ (referring to the measuring length) min. ± 0.006 mm
Hysteresis		≤ 0.03 mm
Supply voltage	V DC	24 (± 25 % with an analogue output)
	Power consumption	mA 80
	Residual ripple	s-s % ≤ 1
	V DC	24 (+ 20 %/– 15 % with a digital output)
	Power consumption	mA 55
	Residual ripple	s-s % ≤ 1
Protection	Tube and flange	IP 67
	Sensor electronics	IP 65
Operating temperature	Sensor electronics	$^{\circ}$ C –40 to +65
	Measuring cable	$^{\circ}$ C –40 to +85
Temperature co-efficient	Voltage	ppm/ $^{\circ}$ C 70
	Current	ppm/ $^{\circ}$ C 90

Position measuring system

Mounting style

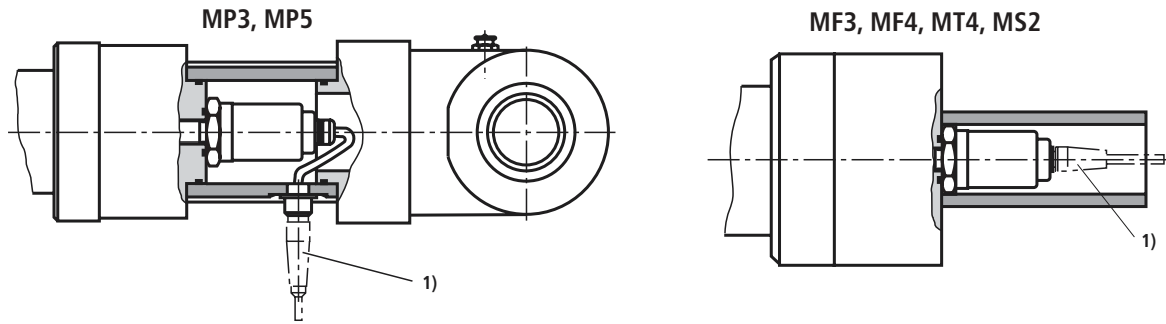

1) For analogue output:
6-pin Amphenol -
Plug-in connector Material No. **R900072231**
(plug-in connector is **not** included within the scope supply, it must be ordered separately)



1) For digital output:
7-pin Amphenol -
Plug-in connector Material No. **R900079551**
(plug-in connector is **not** included within the scope supply, it must be ordered separately)



Connection allocation

Position measuring system (analogue output)

Component plug (viewed on the pin side)

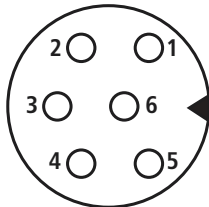

Pin	Cable	Signal / current	Signal / voltage
1	Grey	4...20 mA	0 - 10 V
2	Pink	Gnd	Gnd
3	Yellow	n. c.	10 - 0 V
4	Green	n. c.	Gnd
5	Brown	+24 V DC ($\pm 25\%$)	+24 V DC ($\pm 25\%$)
6	White	Gnd	Gnd

Position measuring system (digital output)

Component plug (viewed on the pin side)

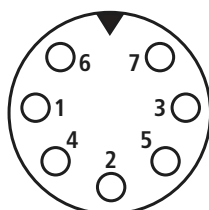

Pin	Cable	Signal / SSi
1	Grey	Data (-)
2	Pink /	Data (+)
3	Yellow	Tact (+)
4	Green	Tact (-)
5	Brown	+24 V DC (+20%/-15%)
6	White	0 V
7	-	n. c.

Proximity switch

CDH2: AL-Ø 40-320 mm

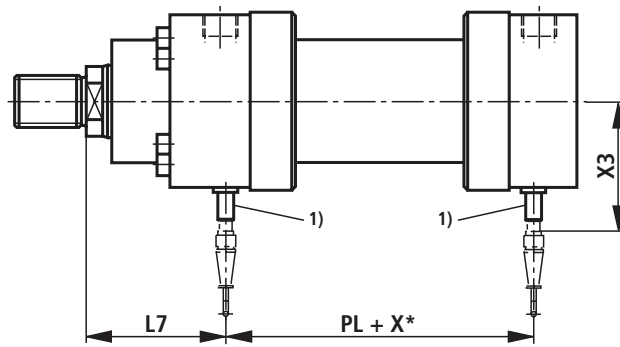

CGH2: AL-Ø 40-320 mm

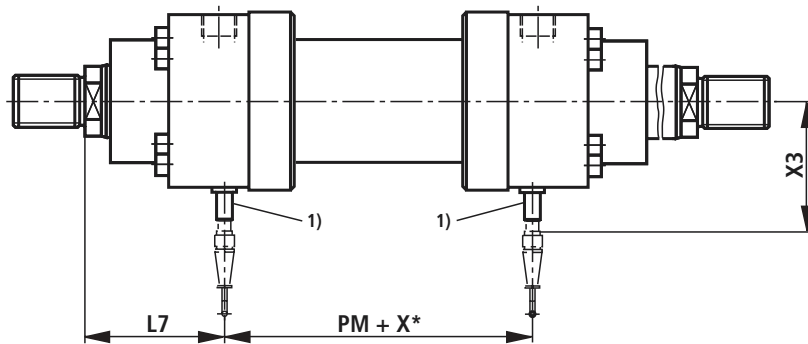

Mounting styles

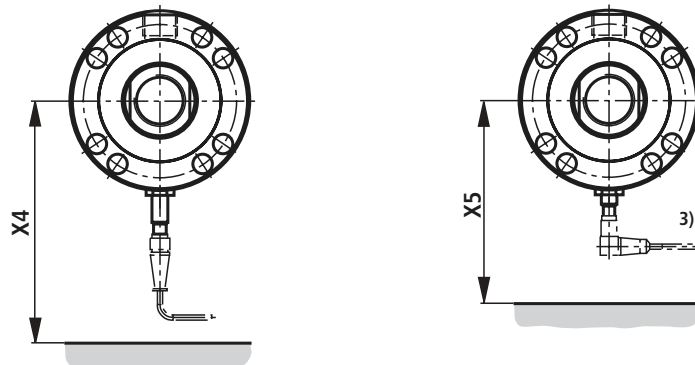

Plug-in connector with a 5m cable

Material No. **R900026512**

(plug-in connector is **not** included within the scope of supply, it must be ordered separately)



Plug-in connector, angled with a 5m cable

(the orientation of the cable exit is not definable)

Material No. **R900021404**

(plug-in connector is **not** included within the scope of supply, it must be ordered separately)

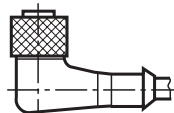

Proximity switch (in mm)

AL Ø	MM Ø	PL	PM	L7	X3	X4	X5
40	25 28	112	112	87	94	170	125
50	32 36	110	110	103	98	175	130
63	40 45	125	125	116	103	180	135
80	50 56	138	138	128,5	108	185	140
100	63 70	161	161	139	116	195	150
125	80 90	193	193	159	126	205	160
140	90 100	209	209	171	146	225	180
160	100 110	228	228	188.5	151	230	185
180	110 125	254	254	199	159	235	190
200	125 140	264	264	227	166	245	200
220	140 160	310	310	252	177 ²⁾	255	— ³⁾
250	160 180	310	310	265	187 ²⁾	265	— ³⁾
280	180 200	369	369	293	199 ²⁾	275	— ³⁾
320	200 220	375	375	290	209 ²⁾	285	— ³⁾

Notes

For main dimensions see page 6 to 17

AL = Piston Ø

MM = Piston rod Ø

X* = Stroke length

1) = The proximity switch is always located opposite to the pipe connection

2) = For piston Ø 220-320 the limit switch does not overhang

3) = For piston Ø 220-320 the angled plug-in connector is not possible

Proximity switch

Inductive proximity switches are used as a reliable end position control for hydraulic cylinders. They are an important element, in providing safety systems, interlocks and/or other machine functions where signals safely and exactly monitor the end position. The up to 500 bar rated high pressure proximity switches operate without contact

and contacts and are, therefore wear free. Due to safety reasons the proximity switch is protected against being screwed in too deep. The switching distance can, therefore not be adjusted. As standard the cylinders are fitted with proximity switches on both sides.

Technical data

Function		PNP N/O
Permissible pressure	bar	500
Operating pressure	V DC	10 ... 30
Including the residual ripple	%	≤ 15
Voltage drop	V	≤ 1.5
Rated operating voltage	V DC	24
Rated operating current	mA	200
No load current	mA	≤ 8
Residual current	µA	≤ 10
Repeatability	%	≤ 5
Hysteresis	%	≤ 15
Ambient temperature range	°C	- 25 ... + 80
Temperature drift	%	≤ 10
Switching frequency	Hz	1000
Protection		
	Active area	IP 68 to DIN 40050
	Proximity switch	IP 67 to DIN 40050
Housing material		Material No. 1.4104

Connection allocation

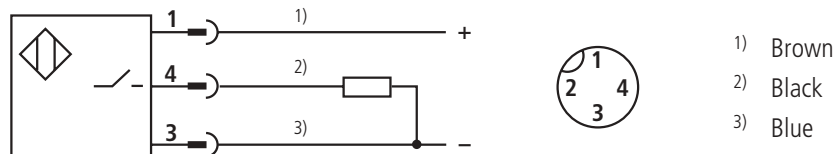

Coupling

Notes

For pressure measurement or bleeding.
For installation in the bleed/measuring port. Coupling with check valve function, i.e. it can also be connected when pressure is present.

Scope of supply:

Coupling AB-E 20-11/K1 with NBR seal

Material No. **R900009090**

Coupling AB-E 20-11/K1 V with FKM seal

Material No. **R900001264**

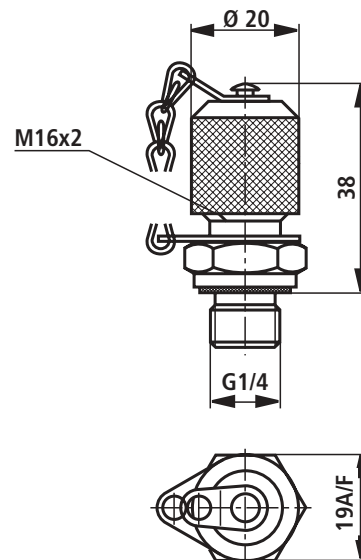

Self-aligning clevis CGKD (in mm)

ISO 6982

DIN 24 338

CETOP RP 88 H

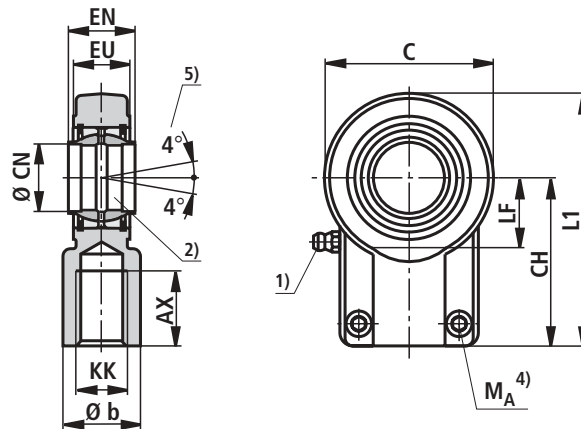

AL Ø	MM Ø	Type	Material No.	AX min.	b	c	CH js16	CN H7	EN h12	EU	KK	LF	L1	M_A ³⁾ Nm	m ⁴⁾ kg
40	25 28	CGKD25	R900323332	29	30	62	65	25	25	23	M20x1,5	27	96	32	0.7
50	32 36	CGKD32	R900322049	37	38	70	80	32	32	27	M27x2	32	118	64	1.2
63	40 45	CGKD40	R900322029	46	47	89	97	40	40	32	M33x2	41	145.5	64	2.1
80	50 56	CGKD50	R900322719	57	58	108	120	50	50	40	M42x2	50	179	110	4.4
100	63 70	CGKD63	R900322028	64	70	132	140	63	63	52	M48x2	62	211	80	7.6
125	80 90	CGKD80	R900322700	86	90	168	180	80	80	66	M64x3	78	270	195	14,5
140	90 100	CGKD90	R900325702	91	100	185	195	90	90	72	M72x3	85	296	195	17
160	100 110	CGKD100	R900322030	96	110	210	210	100	100	84	M80x3	98	322	385	28
180	110 125	CGKD110	R900308153	106	125	235	235	110	110	88	M90x3	105	364	385	32
200	125 140	CGKD125	R900322026	113	135	262	260	125	125	102	M100x3	120	405	385	43
220	140 160	CGKD160	R900300718	126	165	326	310	160	160	130	M125x4	150	488	660	80
250	160 180	CGKD160	R900300718	126	165	326	310	160	160	130	M125x4	150	488	660	80
280	180 200	CGKD200	R900324814	161	215	418	390	200	200	162	M160x4	195	620	1350	165
320	200 220	CGKD200	R900324814	161	215	418	390	200	200	162	M160x4	195	620	1350	165

Notes

AL = Piston Ø

MM = Piston rod Ø

1) = Grease nipple; cone head form A to DIN 71 412

2) = Associated pin Ø r6

³⁾ M_A = Tightening torque

The plain clevis must always be screwed on up to the piston rod thread stop. Subsequently, the clamping screws have to be tightened to the specified torque.

⁴⁾ m = Weight of the self-aligning clevis

⁵⁾ = CGKD 25 swivel angle 1°

Fork clevis CCKB (in mm)

ISO 8132

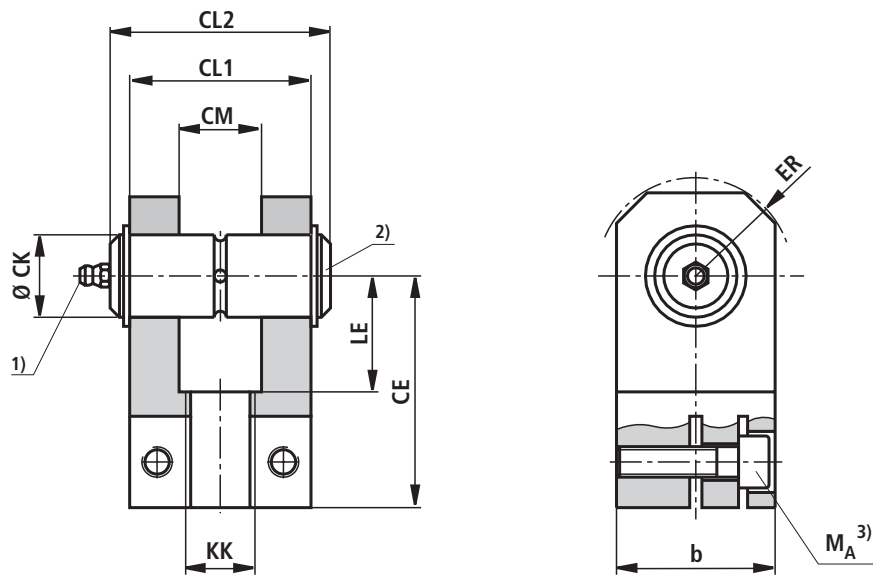

AL Ø	Type	Material No.	b max.	CE js12	CK H9	CL1 h16	CL2	CM A12	ER max.	KK	LE min.	$M_A^{3)}$ Nm	$m^{4)}$ kg
40	CCKB 25	R900542845	50	65	25	56	66	25	32	M20x1.5	34	49	1.4
50	CCKB 32	R900542846	65	80	32	70	78	32	40	M27x2	42	57	2.7
63	CCKB 40	R900542847	80	97	40	90	98	40	50	M33x2	52	99	5.4
80	CCKB 50	R900542848	100	120	50	110	118	50	63	M42x2	64	99	9.5
100	CCKB 63	R900542849	125	140	63	140	150	63	71	M48x2	75	157	21.5
125	CCKB 80	R000542850	160	180	80	170	180	80	90	M64x3	94	240	38.2

Notes

AL = Piston Ø

1) = Grease nipple; cone head form A to DIN 71 412

2) = Associated pin Ø m6;
(the pin and pin retention are included within the scope of supply)

3) M_A = Tightening torque
The plain clevis must always be screwed on up to the piston rod thread stop. Subsequently, the clamping screws have to be tightened to the specified torque.

4) m = Weight of the fork clevis

Trunnion mounting block CLTB (in mm)

ISO 8132

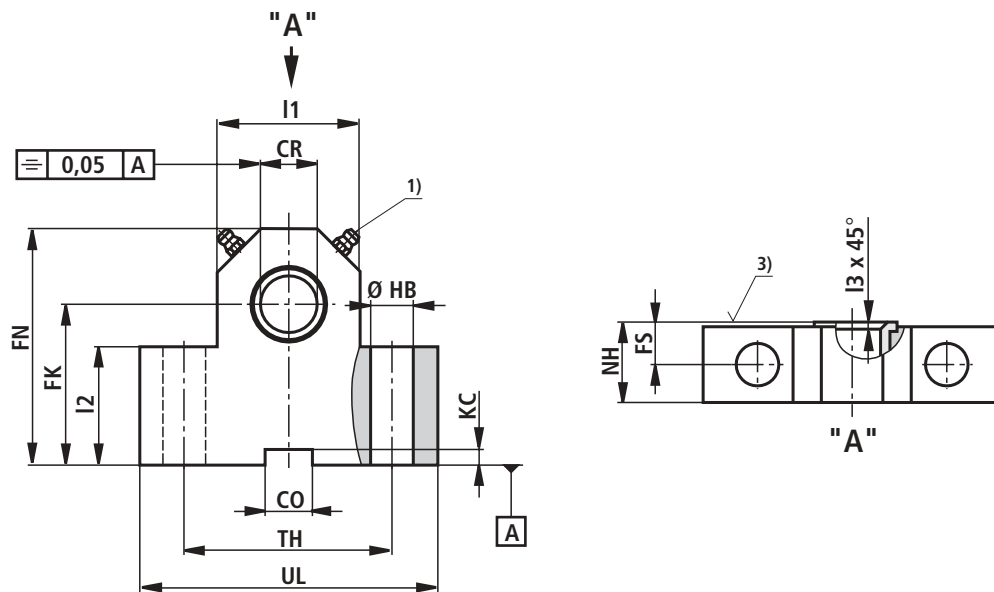

AL Ø	Type	Material No.	CR H7	CO N9	FK js12	FN max.	FS js14	HB H13	KC +0.3	I1	I2	I3	NH max.	TH js14	UL max.	$m^{(2)}$ kg
40	CLTB 25	R900772610 ⁴⁾	25	25	55	80	12	13.5	5.4	56	45	1.5	26	80	110	2.2
50	CLTB 32	R900772611 ⁴⁾	32	25	65	100	15	17.5	5.4	70	52	2	33	110	150	4.7
63	CLTB 40	R900772612 ⁴⁾	40	36	76	120	16	22	8.4	88	60	2.5	41	125	170	7.8
80	CLTB 50	R900772613 ⁴⁾	50	36	95	140	20	26	8.4	100	75	2.5	51	160	210	14.1
100	CLTB 63	R900772614 ⁴⁾	63	50	112	180	25	33	11.4	130	85	3	61	200	265	23.4
125	CLTB 80	R900772615 ⁴⁾	80	50	140	220	31	39	11.4	160	112	3,5	81	250	325	53.1

Notes

AL = Piston Ø

1) = Grease nipple; cone head form A to DIN 71 412

2) m = Weight of the trunnion mounting block (weight per pair)

3) = Mounting surface of the trunnion (inside)

4) = Mounting blocks are always supplied as a pair

Fork type mounting blocks CLCA / CLCD (in mm)

CLCA to ISO 8132, form B

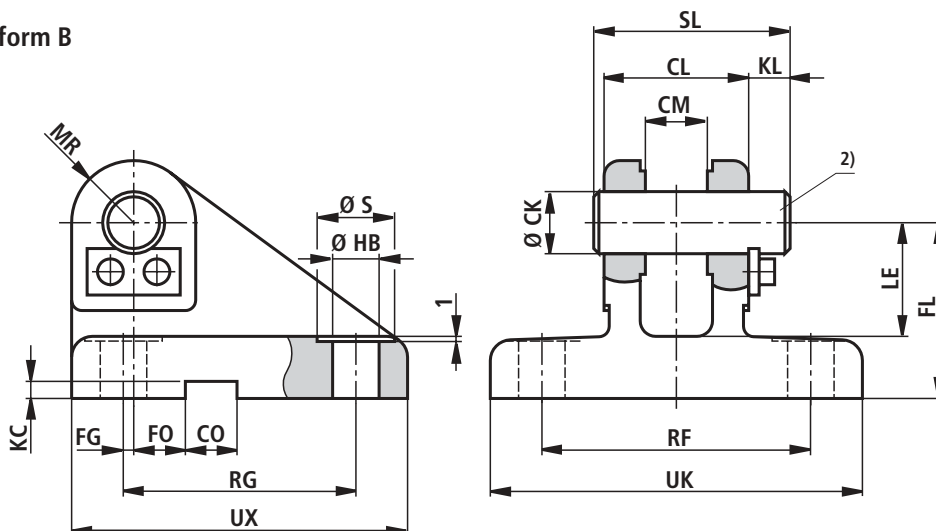

AL Ø	Type	Material No.	CK H9	CL h16	CM A12	CO N9	FG js14	FL js12	FO js14	HB H13	KC +0.3	KL	LE min.	MR max.	RF js14	RG js14	S	SL	UK max.	UX max.	<i>m</i> ¹⁾ kg
40	CLCA 25	R900542864	25	56	25	25	10	55	10	13.5	5.4	10	37	25	90	85	20	69	120	115	3.0
50	CLCA 32	R900542865	32	70	32	25	14.5	65	6	17.5	5.4	13	43	32	110	110	26	86	145	145	5.0
63	CLCA 40	R900542866	40	90	40	36	17.5	76	6	22	8.4	16	52	40	140	125	33	109	185	170	9.6
80	CLCA 50	R900542867	50	110	50	36	25	95	0	26	8.4	19	65	50	165	150	40	132	215	200	15.5
100	CLCA 63	R900542868	63	140	63	50	33	112	0	33	11.4	20	75	63	210	170	48	165	270	230	27.5
125	CLCA 80	R900542869	80	170	80	50	45	140	0	39	11.4	26	95	80	250	210	57	200	320	280	47.0

CLCD to ISO 8132, form A

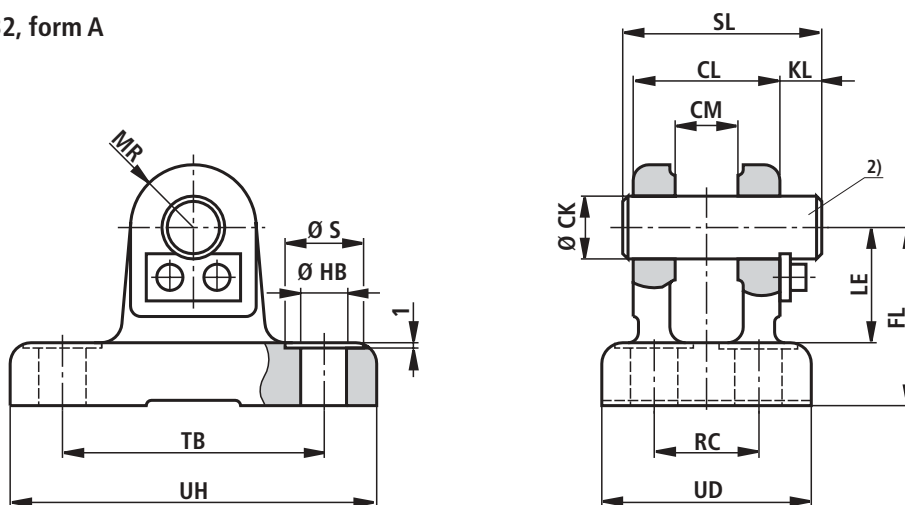

AL Ø	Type	Material No.	CK H9	CL h16	CM A12	FL js12	HB H13	KL	LE min.	MR max.	RC js14	S	SL	TB js14	UD max.	UH max.	<i>m</i> ¹⁾ kg
40	CLCD 25	R900542882	25	56	25	55	13.5	10	37	25	40	20	59	85	70	113	1.9
50	CLCD 32	R900542883	32	70	32	65	17.5	13	43	32	50	26	86	110	85	143	3.0
63	CLCD 40	R900542884	40	90	40	76	22	16	52	40	65	33	109	130	108	170	5.5
80	CLCD 50	R900542885	50	110	50	95	26	19	65	50	80	40	132	170	130	220	10.6
100	CLCD 63	R900542886	63	140	63	112	33	20	75	63	100	48	165	210	160	270	17.0
125	CLCD 80	R900542887	80	170	80	140	39	26	95	80	125	57	200	250	210	320	32.0

Notes

AL = Piston Ø

¹⁾ *m* = Weight of the fork type mounting block

²⁾ = Associated pin Ø m6

(the pin and pin retention are included within the scope of supply)

Buckling

The permissible stroke with a flexibly guided load and 3.5 safety factor against buckling can be obtained from the appropriate table. With a deviating cylinder installation orientation, the permissible stroke has to be interpolated. Permissible stroke lengths for non-guided loads are available on request.

The calculation for buckling are carried out as follows:

1. Calculation according to Euler

$$F = \frac{\pi^2 \cdot E \cdot I}{\nu \cdot L_K^2} \text{ if } \lambda > \lambda_g$$

2. Calculation according to Tetmajer

$$F = \frac{d^2 \cdot \pi (335 - 0,62 \cdot \lambda)}{4 \cdot \nu} \text{ if } \lambda \leq \lambda_g$$

Explanation:

E = Modulus of elasticity in N/mm²

= 2.1 x 10⁵ for steel

I = Moment of inertia in mm⁴ for a circular cross-section area

$$= \frac{d^4 \cdot \pi}{64} = 0.0491 \cdot d^4$$

ν = 3.5 (safety factor)

L_K = Free buckling length in mm (dependent on the mounting style, see sketches A, B, C)

d = Piston rod Ø in mm

λ = Slenderness ratio

$$= \frac{4 \cdot L_K}{d} \quad \lambda_g = \pi \sqrt{\frac{E}{0.8 \cdot R_e}}$$

R_e = Yield strength of the piston rod

The influence of the mounting style on the buckling length:

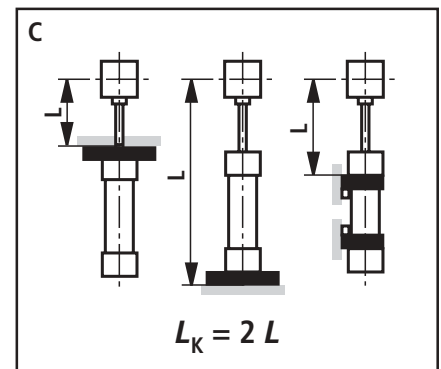
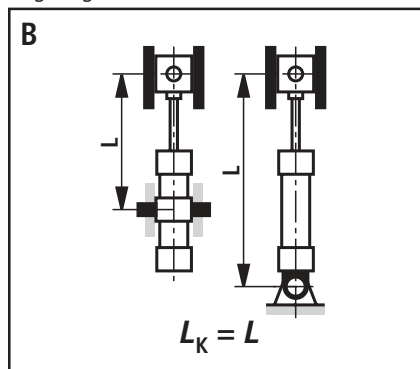
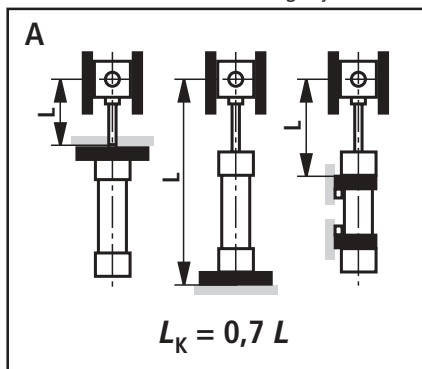

Permissible stroke lengths (in mm)

Mounting styles: MP3, MP5

AL Ø	MM Ø	Permissible stroke at									Max. available stroke	
		100 bar			160 bar			250 bar				
		0°	45°	90°	0°	45°	90°	0°	45°	90°		
40	25	195	200	215	130	135	140	40	45	55	2000	Installation 0°
	28	385	400	445	295	300	320	215	220	225		
	50	32	380	390	430	280	285	300	195	200		
36		505	525	595	395	405	430	290	295	305		
63	40	480	500	550	365	370	385	255	260	265	3000	45°
	45	640	660	750	505	515	550	380	385	395		
80	50	590	615	690	455	465	495	330	335	345	6000	90°
	56	765	800	930	615	630	685	470	475	495		
100	63	750	780	910	595	610	660	445	455	470		
	70	940	985	1195	775	800	885	605	615	650		
125	80	970	1015	1200	780	805	880	595	605	635		
	90	1235	1300	1610	1030	1070	1200	825	840	895		
140	90	1075	1130	1360	875	905	1000	675	685	725		
	100	1335	1405	1770	1120	1165	1325	900	920	985		
160	100	1175	1230	1480	955	985	1085	735	750	785		
	110	1430	1500	1875	1195	1240	1400	955	975	1040		
180	110	1250	1310	1570	1010	1045	1150	775	790	830		
	125	1620	1710	2160	1365	1420	1620	1100	1125	1205		
200	125	1435	1510	1860	1180	1220	1365	915	935	990		
	140	1795	1900	2450	1525	1590	1840	1240	1270	1370		
220	140	1620	1710	2180	1360	1415	1630	1090	1120	1200		
	160	2075	2200	3000	1810	1890	2280	1510	1560	1730		
250	160	1805	1910	2490	1520	1590	1850	1220	1250	1360		
	180	2250	2395	3300	1960	2060	2500	1630	1690	1880		
280	180	2075	2200	2900	1775	1880	2170	1450	1490	1620		
	200	2510	2670	3700	2200	2310	2820	1850	1920	2140		
320	200	2135	2270	3030	1820	1900	2260	1470	1510	1660		
	220	2550	2720	3820	2230	2340	2880	1860	1930	2170		

Permissible stroke lengths (in mm)

Mounting style: MF3

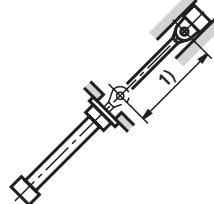
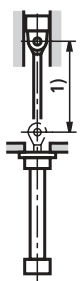
AL Ø	MM Ø	Permissible stroke at									Max. available stroke		
		100 bar			160 bar			250 bar					
		0°	45°	90°	0°	45°	90°	0°	45°	90°			
40	25 28	895	915	980	730	735	760	440	450	510	2000	Installation 0° 	
		1400	1415	1630	1180	1205	1275	970	980	1010			
	50	32 36	1440	1490	1670	1210	1230	1300	985	995			1025
1760			1830	2000	1510	1545	1675	1255	1270	1320			
63	40 45	1735	1800	2000	1475	1510	1620	1215	1230	1270			
		2000	2000	2000	1830	1880	2080	1540	1560	1640			
80	50 56	2000	2000	2000	1810	1850	1995	1495	1515	1570			
		2000	2000	2000	2000	2000	2000	1870	1900	2000			
100	63 70	2580	2690	3000	2235	2300	2550	1875	1910	2010		3000	45° 
		3000	3000	3000	2690	2780	3000	2300	2350	2520			
125	80 90	3000	3000	3000	2840	2930	3000	2400	2450	2590			
		3000	3000	3000	3000	3000	3000	3000	3000	3000			
140	90 100	3000	3000	3000	3000	3000	3000	2700	2760	2950			
		3000	3000	3000	3000	3000	3000	3000	3000	3000			
160	100 110	3000	3000	3000	3000	3000	3000	2920	2980	3000			
		3000	3000	3000	3000	3000	3000	3000	3000	3000			
180	110 125	3000	3000	3000	3000	3000	3000	3000	3000	3000			
		3000	3000	3000	3000	3000	3000	3000	3000	3000			
200	125 140	3000	3000	3000	3000	3000	3000	3000	3000	3000			
		3000	3000	3000	3000	3000	3000	3000	3000	3000			
220	140 160	5400	5680	6000	4800	4980	5780	4120	4220	4560	6000	90° 	
		6000	6000	6000	5820	6000	6000	5150	5330	6000			
250	160 180	5850	6000	6000	5270	5500	6000	4600	4740	5250			
		6000	6000	6000	6000	6000	6000	5650	5850	6000			
280	180 200	6000	6000	6000	6000	6000	6000	5270	5420	5970			
		6000	6000	6000	6000	6000	6000	6000	6000	6000			
320	200 220	6000	6000	6000	6000	6000	6000	5950	6000	6000			
		6000	6000	6000	6000	6000	6000	6000	6000	6000			

Mounting style: MF4

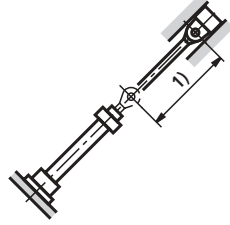
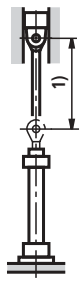
AL Ø	MM Ø	Permissible stroke at									Max. available stroke		
		100 bar			160 bar			250 bar					
		0°	45°	90°	0°	45°	90°	0°	45°	90°			
40	25 28	325	340	370	245	250	260	105	110	140	2000	Installation 0° 	
		565	590	695	465	475	520	365	370	385			
	50	32 36	600	625	715	485	495	530	370	375			390
755			790	950	630	650	715	505	515	540			
63	40 45	730	765	905	600	615	675	470	480	500			
		920	965	1190	780	805	905	630	645	685			
80	50 56	910	950	1130	750	775	845	595	605	630			
		1125	1185	1470	960	990	1120	785	800	850			
100	63 70	1120	1175	1460	945	980	1105	770	785	835		3000	45° 
		1350	1430	1860	1175	1220	1420	980	1000	1090			
125	80 90	1430	1510	1910	1225	1270	1450	1000	1025	1100			
		1750	1855	2490	1540	1610	1910	1300	1340	1470			
140	90 100	1585	1675	2170	1370	1425	1650	1135	1165	1260			
		1895	2010	2750	1675	1755	2110	1425	1470	1630			
160	100 110	1725	1820	2340	1490	1545	1780	1230	1260	1360			
		2030	2150	2900	1785	1870	2230	1510	1560	1720			
180	110 125	1855	1960	2510	1595	1660	1910	1315	1350	1450			
		2300	2440	3350	2040	2130	2580	1735	1790	1990			
200	125 140	2105	2230	2950	1830	1910	2250	1530	1570	1715			
		2535	2700	3000	2260	2370	2920	1940	2010	2255			
220	140 160	2250	2400	3350	1990	2090	2550	1685	1740	1950	6000	90° 	
		2800	2990	4500	2530	2680	3480	2220	2310	2700			
250	160 180	2600	2770	3900	2310	2430	3000	1975	2040	2300			
		3130	3350	5050	2840	3000	3910	2500	2600	3040			
280	180 200	2850	3050	4400	2550	2680	3370	2190	2270	2600			
		3370	3610	5550	3070	3250	4300	2700	2820	3330			
320	200 220	3070	3270	4750	2750	2890	3650	2150	2460	2810			
		3560	3820	5850	3250	3430	4550	2860	2980	3530			

Permissible stroke lengths (in mm)

Mounting style: MT4 (trunnion located in the middle of the cylinder)

AL Ø	MM Ø	Permissible stroke at									Max. available stroke			
		100 bar			160 bar			250 bar						
		0°	45°	90°	0°	45°	90°	0°	45°	90°				
40	25 28	340	345	365	250	255	260	130	135	145	2000	Installation 0°		
		590	605	665	470	480	500	365	370	375				
	50	32 36	600	615	670	470	480	495	355	360				365
			770	795	890	625	635	670	485	490				505
63	40 45	740	765	845	590	600	630	450	455	465				
		940	975	1115	770	790	845	610	620	640				
80	50 56	920	950	1055	735	750	790	570	575	590				
		1155	1195	1375	950	975	1045	755	765	790				
100	63 70	1145	1190	1365	940	960	1030	740	750	775		3000	45°	
		1400	1460	1740	1180	1210	1330	955	970	1015				
125	80 90	1470	1530	1780	1220	1250	1350	970	985	1020				
		1820	1910	2320	1550	1600	1780	1275	1300	1370				
140	90 100	1640	1710	2020	1370	1410	1540	1100	1120	1170				
		1980	2080	2570	1700	1755	1970	1400	1430	1515				
160	100 110	1780	1850	2180	1485	1520	1660	1190	1210	1260				
		2110	2210	2710	1800	1860	2080	1480	1510	1595				
180	110 125	1910	1990	2340	1590	1635	1780	1275	1295	1350				
		2405	2530	3000	2065	2130	2400	1710	1740	1850				
200	125 140	2180	2280	2740	1840	1890	2090	1490	1510	1590				
		2660	2800	3000	2300	2380	2720	1915	1960	2100				
220	140 160	2490	2510	3150	2050	2120	2400	1685	1720	1835	6000	90°		
		3000	3170	4230	2640	2750	3260	2240	2310	2530				
250	160 180	2730	2870	3640	2350	2440	2790	1950	1990	2140				
		3320	3520	4720	2940	3060	3650	2500	2570	2830				
280	180 200	3040	3210	4140	2640	2750	3170	2210	2260	2440				
		3620	3840	5210	3210	3360	4040	2750	2830	3140				
320	200 220	3250	3430	4455	2820	2930	3410	2360	2420	2620				
		3800	4030	5500	3370	3530	4250	2880	2970	3290				

Mounting style: MS2

AL Ø	MM Ø	Permissible stroke at									Max. available stroke			
		100 bar			160 bar			250 bar						
		0°	45°	90°	0°	45°	90°	0°	45°	90°				
40	25 28	825	840	885	645	650	665	370	375	410	2000	Installation 0°		
		1305	1350	1535	1085	1110	1180	875	885	910				
	50	32 36	1330	1375	1560	1095	1120	1190	875	885				910
			1645	1715	2030	1395	1430	1560	1140	1160				1210
63	40 45	1610	1670	1950	1345	1380	1490	1085	1100	1145				
		1980	2000	2000	1700	1750	1950	1410	1435	1510				
80	50 56	1980	2000	2000	1665	1710	1850	1350	1370	1425				
		2000	2000	2000	2000	2000	2000	1730	1760	1860				
100	63 70	2420	2535	3000	2080	2140	2390	1720	1750	1850		3000	45°	
		2880	3000	3000	2530	2630	3000	2140	2190	2360				
125	80 90	3000	3000	3000	2660	2750	3000	2220	2270	2410				
		3000	3000	3000	3000	3000	3000	2810	2890	3000				
140	90 100	3000	3000	3000	2970	3000	3000	2490	2550	2740				
		3000	3000	3000	3000	3000	3000	3000	3000	3000				
160	100 110	3000	3000	3000	3000	3000	3000	2690	2750	2950				
		3000	3000	3000	3000	3000	3000	3000	3000	3000				
180	110 125	3000	3000	3000	3000	3000	3000	2890	2960	3000				
		3000	3000	3000	3000	3000	3000	3000	3000	3000				
200	125 140	3000	3000	3000	3000	3000	3000	3000	3000	3000				
		3000	3000	3000	3000	3000	3000	3000	3000	3000				
220	140 160	5090	5370	6000	4490	4670	5470	3820	3910	4260	6000	90°		
		6000	6000	6000	5510	5800	6000	4850	5020	5750				
250	160 180	5520	5860	6000	4940	5170	6000	4270	4410	4920				
		6000	6000	6000	6000	6000	6000	5320	5520	6000				
280	180 200	6000	6000	6000	5700	5960	6000	4930	5070	5630				
		6000	6000	6000	6000	6000	6000	6000	6000	6000				
320	200 220	6000	6000	6000	5890	6000	6000	4750	5310	6000				
		6000	6000	6000	6000	6000	6000	6000	6000	6000				

End position cushioning

Self adjusting end position cushioning

The objective is to reduce the speed of a moving mass, whose centre of gravity lies on the cylinder axis, to a level, at which neither the cylinder nor the machine, into which the cylinder is installed, can be damaged.

The self adjusting end position cushioning produces a controlled deceleration in both end position (braking). The effective cushioning length adjusts automatically to the current requirements.

The calculation depends on the factors of weight, velocity, system pressure and installation position. Therefore, the variable D_m is to be calculated from weight and speed, the variable D_p from the system pressure and installation position. These variables are then used to verify the permissible cushioning performance in the "cushioning capacity" diagram. The intersection point of the variables D_m and D_p must always be below the cushioning capacity curve of the selected cylinder.

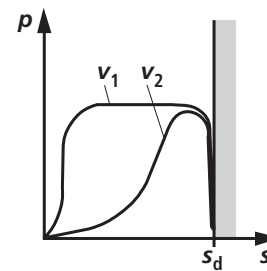
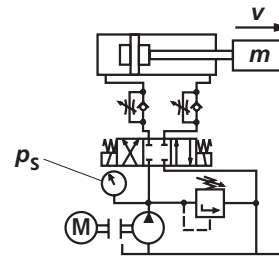

Formulas:

$$D_m = \frac{m}{10^k} ; \quad K = kv (0,5-v)$$

- m = Moved mass in kg
- v = Stroke velocity in m/s
- kv = See table on page 36

Extending:

$$D_p = p_s - \frac{m \cdot 9,81 \cdot \sin \alpha}{A_1 \cdot 10}$$

Retracting:

$$D_p = p_s + \frac{m \cdot 9,81 \cdot \sin \alpha}{A_3 \cdot 10}$$

- p_s = System pressure in bar
- A_1 = Piston area in cm^2 (see page 2)
- A_3 = Annulus area in cm^2 (see page 2)
- α = Angle in degrees with reference to the horizontal plane

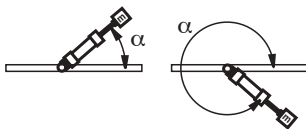
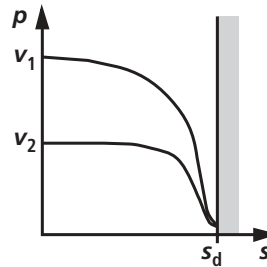

Damping length

AL Ø mm	40	50	63	80	100	125	140	160	180	200	220	250	280	320
Head side	21	20	23	25	25	25	33	33	37	37	76	81	86	90
Base side	21	20	23	25	25	25	33	33	37	37	76	81	86	90

End position cushioning

AL Ø mm	40	50	63	80	100	125	140	160	180	200	220	250	280	320
kv ①	2.85	2.97	2.56	2.82	3.51	3.02	2.53	2.65	2.91	2.76	2.85	2.95	3.11	3.13
kv ②	3.1	3.25	2.85	2.85	3.52	2.91	2.53	2.93	2.95	2.95	2.93	3.1	3.12	3.07
kv ③	2.95	3.1	2.73	3.1	3.51	2.95	2.51	2.91	2.95	2.91	2.93	2.93	3.15	3.25

Cushioning capacity: Extending

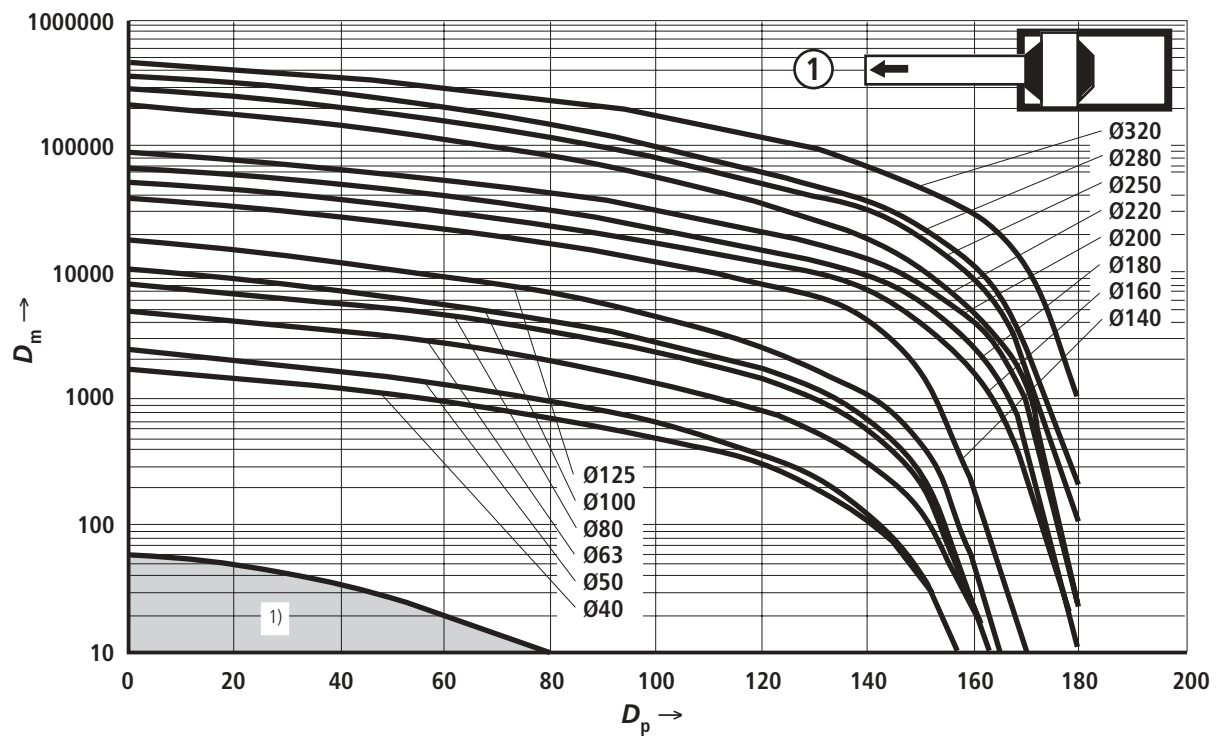

Notes

AL = Piston Ø

- ¹⁾ If, for standard applications, the calculated section point from D_m and D_p is within the indicated area, then we recommend that a cylinder is used without end position damping.

End position cushioning

Cushioning capacity: Retracting

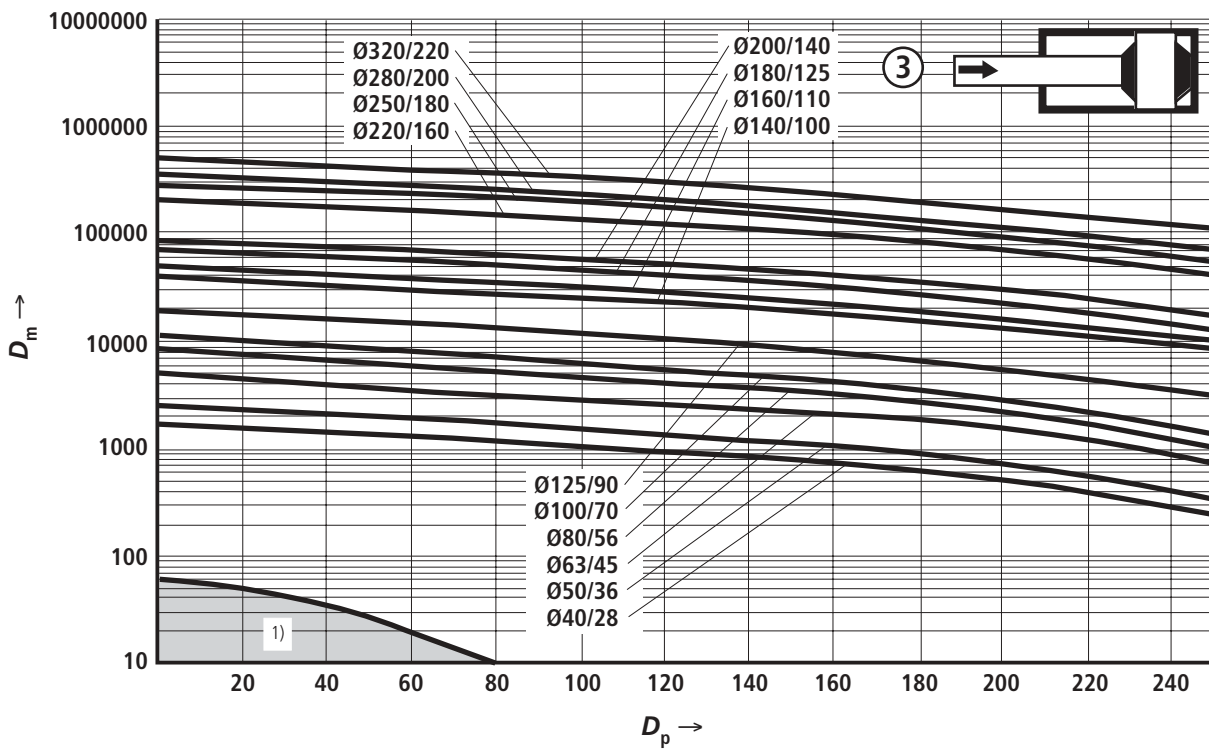
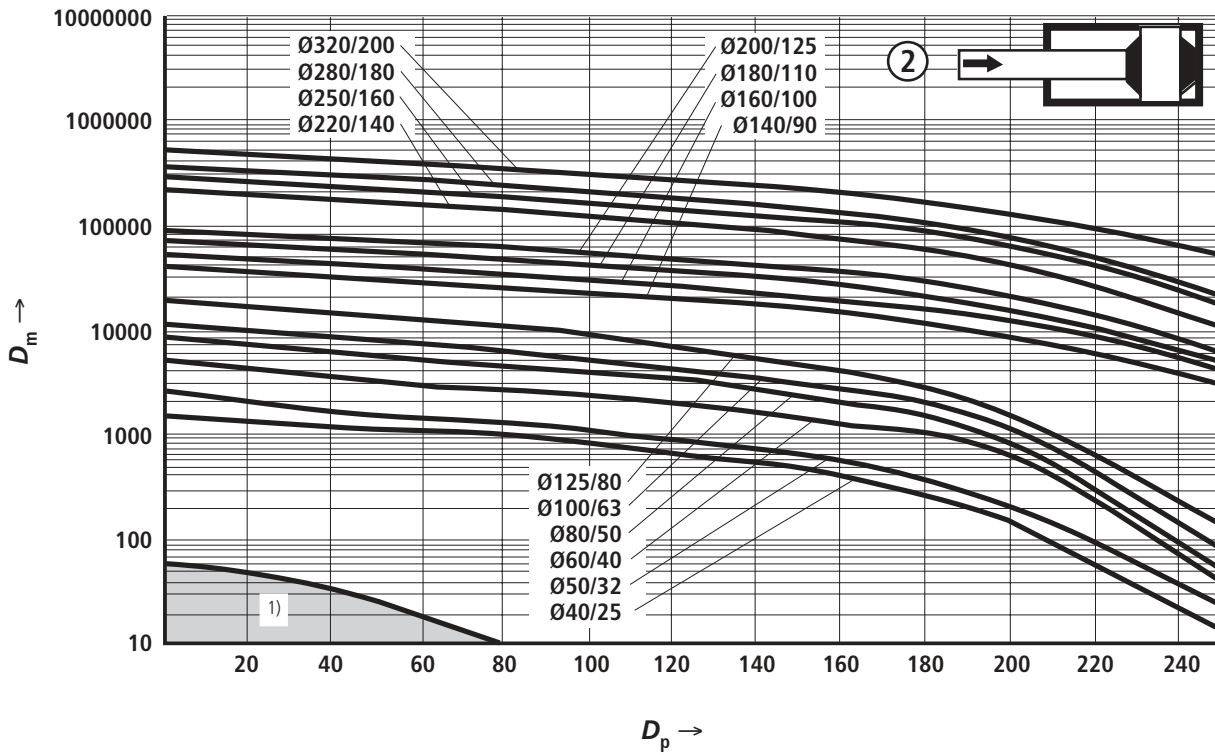

Notes

- 1) If, for standard applications, the calculated section point from D_m and D_p is within the indicated area, then we recommend that a cylinder is used without end position cushioning.

Spare parts

CDH2; AL-Ø 40-320 mm

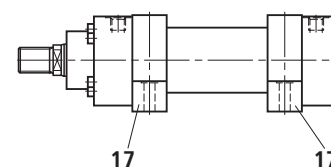
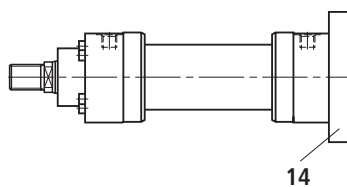
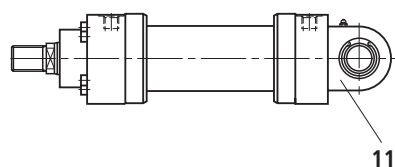
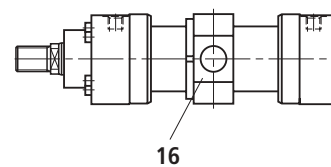
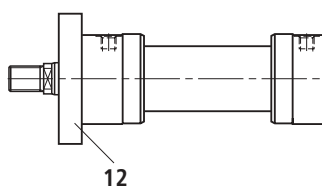
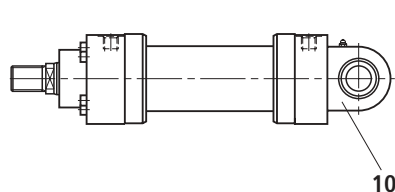
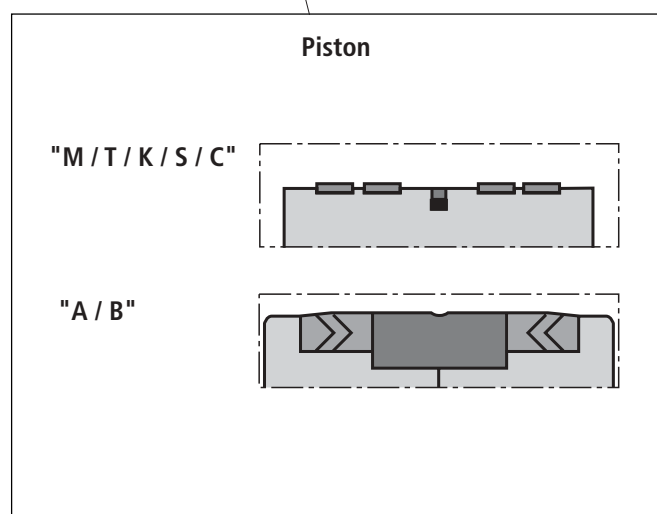
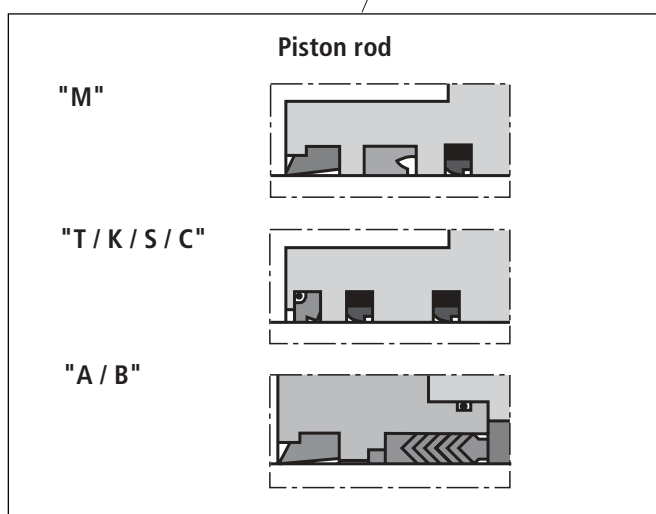
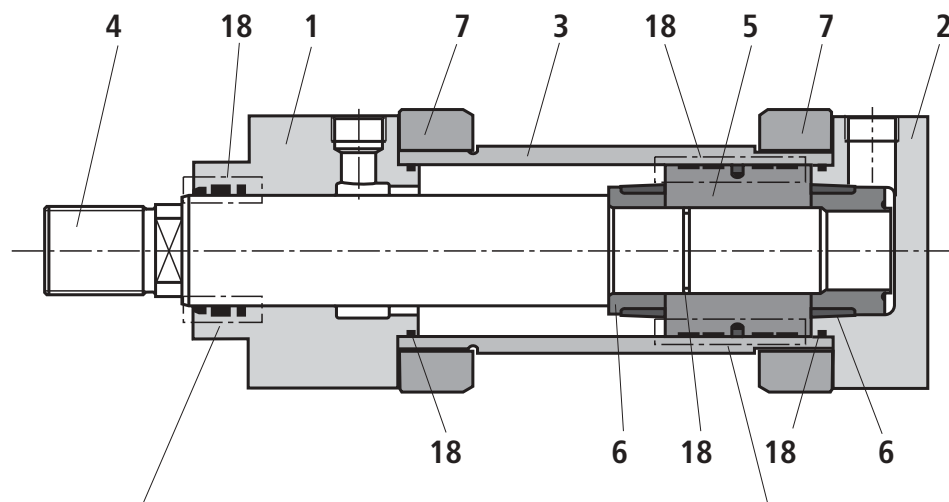

- 1 Head
- 2 Base
- 3 Barrel
- 4 Piston rod
- 5 Piston
- 6 Cushioning bush
- 7 Flange
- 10 Base MP3
- 11 Base MP5
- 12 Round flange MF3

- 14 Round flange MF4
- 16 Trunnion MT4
- 17 Foot MS2
- 18 Seal kit:
 - Wiper
 - Rod seal
 - Piston seal
 - O-ring
 - Guide bush

Spare parts

CGH2; AL-Ø 40-320 mm

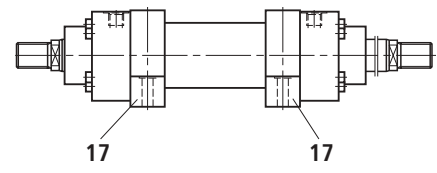
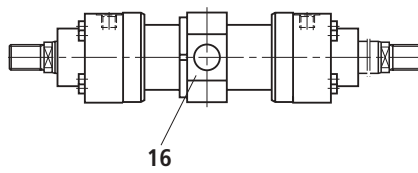
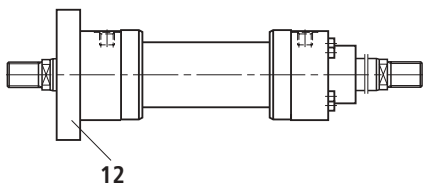
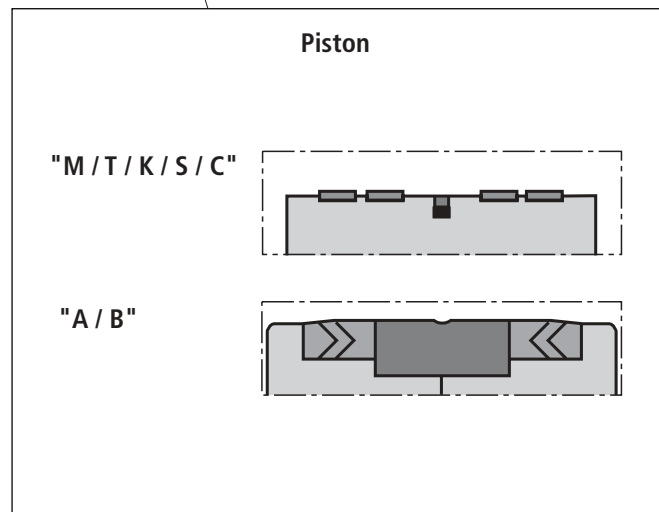
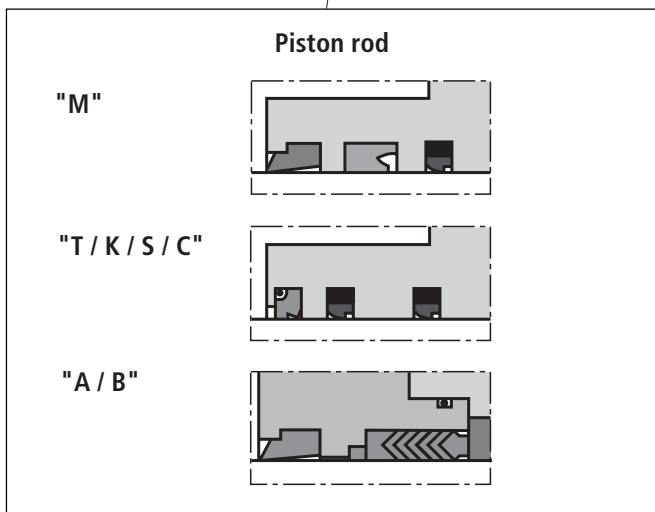
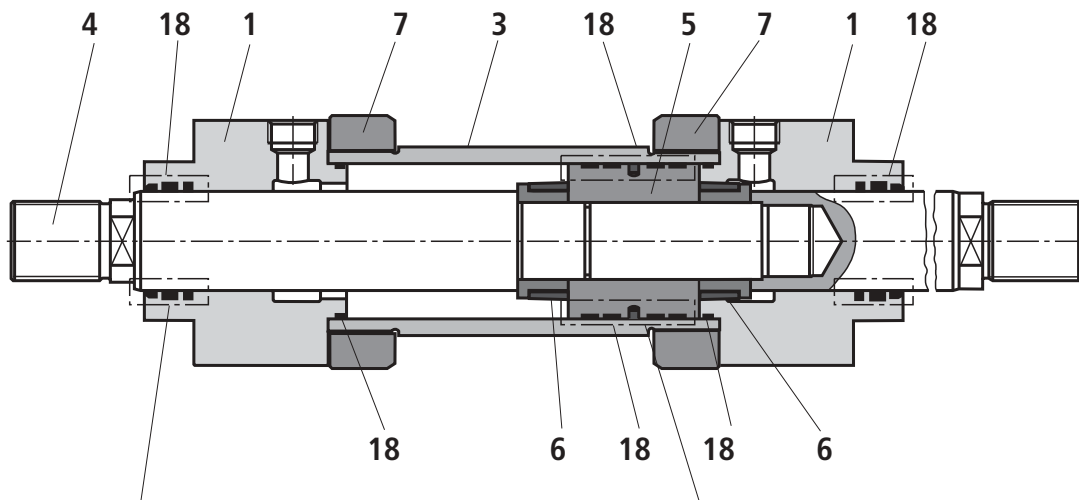

- | | |
|---------------------|--------------------|
| 1 Head | 16 Trunnion MT4 |
| 3 Barrel | 17 Foot MS2 |
| 4 Piston rod | 18 Seal kit: Wiper |
| 5 Piston | Rod seal |
| 6 Cushioning bush | Piston seal |
| 7 Flange | O-ring |
| 12 Round flange MF3 | Guide bush |

Tightening torques

Screws: Head and base (Pos. 1 and 2)

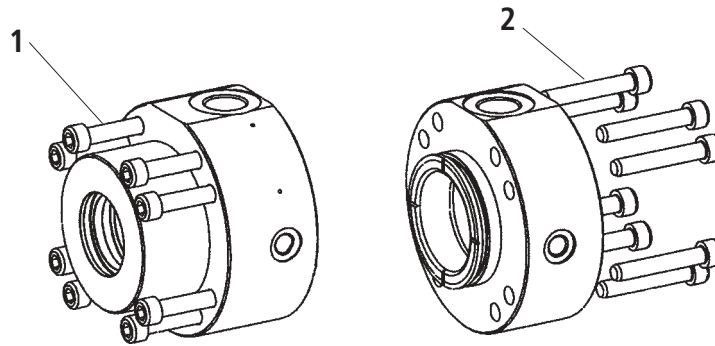

Series	Piston Ø	Screw	Quantity	Grade	Tightening torque
CDH2 / CGH2	40	M8	4	10.9	23 Nm
CDH2 / CGH2	50	M8	8	10.9	20 Nm
CDH2 / CGH2	63	M8	8	10.9	30 Nm
CDH2 / CGH2	80	M10	8	10.9	55 Nm
CDH2 / CGH2	100	M12	8	10.9	100 Nm
CDH2 / CGH2	125	M16	8	10.9	200 Nm
CDH2 / CGH2	140	M16	12	10.9	170 Nm
CDH2 / CGH2	160	M16	12	10.9	220 Nm
CDH2 / CGH2	180	M20	12	10.9	350 Nm
CDH2 / CGH2	200	M20	12	10.9	410 Nm
CDH2 / CGH2	220	M20	16	10.9	460 Nm
CDH2 / CGH2	250	M24	16	10.9	700 Nm
CDH2 / CGH2	280	M30	12	10.9	1700 Nm
CDH2 / CGH2	320	M30	16	10.9	1500 Nm

Screws: Seal cover (Pos. 3)

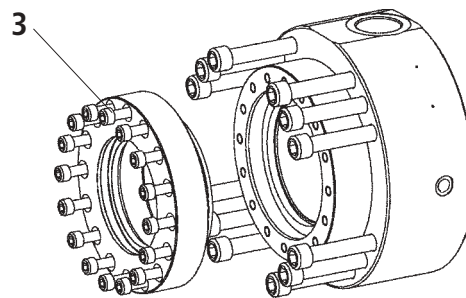

Series	Piston Ø	Piston rod Ø	Screw	Quantity	Grade	Tightening torque
CDH2 / CGH2	160	100	M10	16	10.9	60 Nm
		110				
CDH2 / CGH2	180	110	M12	16	10.9	80 Nm
		125				
CDH2 / CGH2	200	125	M12	16	10.9	90 Nm
		140				
CDH2 / CGH2	220	140	M12	16	10.9	90 Nm
		160		24		
CDH2 / CGH2	250	160	M12	24	10.9	90 Nm
		180				
CDH2 / CGH2	280	180	M12	24	10.9	90 Nm
		200				
CDH2 / CGH2	320	200	M12	24	10.9	90 Nm
		220	M16	16		230 Nm

Seal kits¹⁾

CDH2 – Standard

AL Ø	MM Ø	Material No. Seal version				
		M	T	A	S	B
40	25	R901010141	R901010143	R901010145	R901010146	R901010147
	28	R900851087	R900858841	R900859445	R900861001	R900859770
50	32	R900860274	R900860275	R900860929	R900861003	R900860939
	36	R900849392	R900860277	R900851515	R900861004	R900860940
63	40	R900859509	R900860279	R900851637	R900861006	R900860941
	45	R900847956	R900847855	R900851638	R900861007	R900859678
80	50	R900857129	R900860281	R900856092	R900861009	R900860943
	56	R900850905	R900856180	R900854718	R900861010	R900851205
100	63	R900860283	R900860284	R900856093	R900861012	R900860945
	70	R900853382	R900860285	R900856094	R900861013	R900860946
125	80	R900860287	R900860288	R900860931	R900861015	R900860950
	90	R900857949	R900856102	R900856095	R900861016	R900855464
140	90	R900858281	R900860289	R900860932	R900861017	R900860951
	100	R900853965	R900860290	R900856096	R900849080	R900860952
160	100	R900855683	R900860291	R900860468	R900861018	R900860953
	110	R900851146	R900857536	R900860933	R900861019	R900860954
180	110	R900856497	R900852561	R900860934	R900861020	R900860955
	125	R900848603	R900860292	R900860935	R900861021	R900860956
200	125	R900860294	R900860295	R900860936	R900861022	R900860957
	140	R900856431	R900860293	R900860937	R900861023	R900860958
220	140	R900888100	R900888108	R900888116	R900888132	R900888140
	160	R900888101	R900888109	R900888117	R900888133	R900888141
250	160	R900888102	R900888110	R900888118	R900888134	R900888142
	180	R900888103	R900888111	R900888119	R900888135	R900888143
280	180	R900888104	R900888112	R900888120	R900888136	R900888144
	200	R900888105	R900888113	R900888121	R900888137	R900888145
320	200	R900888106	R900888114	R900888122	R900888138	R900888146
	220	R900888107	R900888115	R900888123	R900888139	R900888147

Notes

AL = Piston Ø

MM = Piston rod Ø

¹⁾ = Seal kits for position measuring systems and proximity switches have separate Material Nos.

Seal kits¹⁾

CGH2 – Standard

AL Ø	MM Ø	Material No. Seal version				
		M	T	A	S	B
40	25	R901010159	R901010161	R901010162	R901010169	R901010170
	28	R900867252	R900868889	R900866747	R900868943	R900867133
50	32	R900867254	R900868891	R900866749	R900868945	R900857135
	36	R900864930	R900868892	R900866750	R900868946	R900867136
63	40	R900867261	R900868894	R900866752	R900868948	R900867138
	45	R900867262	R900868895	R900866753	R900868949	R900867139
80	50	R900867264	R900868897	R900866755	R900868951	R900867141
	56	R900867265	R900868898	R900866756	R900868952	R900867142
100	63	R900867267	R900868900	R900866758	R900868954	R900867144
	70	R900867268	R900868901	R900866759	R900868955	R900867146
125	80	R900860730	R900868903	R900866761	R900868956	R900867148
	90	R900867270	R900868904	R900866762	R900868957	R900867149
140	90	R900867271	R900868905	R900866763	R900868958	R900867150
	100	R900867272	R900868906	R900866764	R900868959	R900867151
160	100	R900867273	R900868907	R900866765	R900868960	R900867152
	110	R900867274	R900868908	R900866766	R900868961	R900867153
180	110	R900867275	R900868909	R900866767	R900868962	R900867154
	125	R900867276	R900868910	R900866768	R900868963	R900867155
200	125	R900867277	R900868911	R900866769	R900868964	R900867156
	140	R900867278	R900868912	R900866770	R900868965	R900867157
220	140	R900888020	R900888028	R900888036	R900888052	R900888060
	160	R900888021	R900888029	R900888037	R900888053	R900888061
250	160	R900888022	R900888030	R900888038	R900888054	R900888062
	180	R900888023	R900888031	R900888039	R900888055	R900888063
280	180	R900888024	R900888032	R900888040	R900888056	R900888064
	200	R900888025	R900888033	R900888041	R900888057	R900888065
320	200	R900888026	R900888034	R900888042	R900888058	R900888066
	220	R900888027	R900888035	R900888043	R900888059	R900888067

Notes

AL = Piston Ø

MM = Piston rod Ø

¹⁾ = Seal kits for proximity switches have separate Material Nos.

Seal kits¹⁾

CDH2 – Standard + Option F

AL Ø	MM Ø	Material No. Seal version		
		M+F	T+F	S+F
40	25	R901010148	R901010149	R901010150
	28	R900861025	R900861050	R900861100
50	32	R900861027	R900861052	R900861102
	36	R900861028	R900861053	R900861103
63	40	R900861030	R900861055	R900861105
	45	R900861031	R900861056	R900861106
80	50	R900861033	R900861058	R900861108
	56	R900861034	R900861059	R900861109
100	63	R900861036	R900861061	R900861114
	70	R900861037	R900861062	R900861115
125	80	R900861039	R900861064	R900861120
	90	R900861040	R900861065	R900861122
140	90	R900861041	R900861066	R900861124
	100	R900861042	R900861067	R900861126
160	100	R900861043	R900861068	R900861128
	110	R900861044	R900861069	R900861130
180	110	R900861045	R900861070	R900861133
	125	R900861046	R900861071	R900861135
200	125	R900861047	R900861072	R900861142
	140	R900861048	R900861073	R900861143

CGH2 – Standard + Option F

AL Ø	MM Ø	Material No. Seal version		
		M+F	T+F	S+F
40	25	R901010151	R901010154	R901010156
	28	R900868999	R900869026	R900869093
50	32	R900869001	R900869028	R900869095
	36	R900869002	R900869029	R900869096
63	40	R900869004	R900869031	R900869098
	45	R900869005	R900869032	R900869099
80	50	R900869007	R900869034	R900869101
	56	R900869008	R900869035	R900869102
100	63	R900869012	R900869037	R900869104
	70	R900869013	R900869038	R900869105
125	80	R900869015	R900869040	R900869107
	90	R900869016	R900869041	R900869108
140	90	R900869017	R900869042	R900869109
	100	R900869018	R900869043	R900869110
160	100	R900869019	R900869044	R900869111
	110	R900869020	R900869045	R900869112
180	110	R900869021	R900869046	R900869113
	125	R900869022	R900869047	R900869114
200	125	R900869023	R900869048	R900869115
	140	R900869024	R900869049	R900869116

Notes

AL = Piston Ø

MM = Piston rod Ø

¹⁾ = Seal kits for proximity switches have separate Material Nos.

Seal kits

Position measuring system

AL Ø	Material No. Seal version				
	M / M+F	T / T+F	A	S / S+F	B
40	R900885935		–	R900885937	–
50	R900894958		–	R900894979	–
63	R900894959		–	R900894980	–
80	R900894960		–	R900894981	–
100	R900894961		–	R900894982	–
125	R900894962		–	R900894983	–
140	R900894963		–	R900894985	–
160	R900894964		–	R900894986	–
180	R900894973		–	R900894987	–
200	R900894974		–	R900894988	–
220	R900894975		–	R900894989	–
250	R900894976		–	R900894991	–
280	R900894977		–	R900894993	–
320	R900894978		–	R900894994	–

Proximity switch

AL Ø	Material No. Seal version				
	M / M+F	T / T+F	A	S / S+F	B
40 - 200	R900885938			R900885939	
220 - 320	R900894997			R900894998	

Note

AL = Piston Ø

The data specified above only serves to describe the product. No statements concerning a certain condition or suitability for a certain application can be derived from our information. The details stated do not release you from the responsibility for carrying out your own assessment and verification.

It must be remembered that our products are subject to a natural process of wear and ageing.

Bosch Rexroth AG
Industrial Hydraulics

D-97813 Lohr am Main
Zum Eisengießer 1 • D-97816 Lohr am Main
Telefon 0 93 52 / 18-0
Telefax 0 93 52 / 18-23 58 • Telex 6 89 418-0
eMail documentation@boschrexroth.de
Internet www.boschrexroth.de

Bosch Rexroth SA

BP 37 – Z.I. Les Fourmis
F-74131 Bonneville Cedex
Tel. +33(0)4 50 25 35 45
Fax +33(0)4 50 25 35 19
Internet www.boschrexroth.fr

Bosch Rexroth Teknik AB

Varuvägen 7, Älvsjö
S-125 81 Stockholm
Tel. +46(08) 72 79 20 0
Fax +46(08) 86 87 21
eMail cyl.hyd@boschrexroth.se
Internet www.boschrexroth.se
